

Texas Commission on Environmental Quality

Edwards Aquifer Application Cover Page

Our Review of Your Application

The Edwards Aquifer Program staff conducts an administrative and technical review of all applications. The turnaround time for administrative review can be up to 30 days as outlined in 30 TAC 213.4(e). Generally administrative completeness is determined during the intake meeting or within a few days of receipt. The turnaround time for technical review of an administratively complete Edwards Aquifer application is 90 days as outlined in 30 TAC 213.4(e). Please know that the review and approval time is directly impacted by the quality and completeness of the initial application that is received. In order to conduct a timely review, it is imperative that the information provided in an Edwards Aquifer application include final plans, be accurate, complete, and in compliance with [30 TAC 213](#).

Administrative Review

1. [Edwards Aquifer applications](#) must be deemed administratively complete before a technical review can begin. To be considered administratively complete, the application must contain completed forms and attachments, provide the requested information, and meet all the site plan requirements. The submitted application and plan sheets should be final plans. Please submit one full-size set of plan sheets with the original application, and half-size sets with the additional copies.

To ensure that all applicable documents are included in the application, the program has developed tools to guide you and web pages to provide all forms, checklists, and guidance. Please visit the below website for assistance: <http://www.tceq.texas.gov/field/eapp>.

2. This Edwards Aquifer Application Cover Page form (certified by the applicant or agent) must be included in the application and brought to the administrative review meeting.
3. Administrative reviews are scheduled with program staff who will conduct the review. Applicants or their authorized agent should call the appropriate regional office, according to the county in which the project is located, to schedule a review. The average meeting time is one hour.
4. In the meeting, the application is examined for administrative completeness. Deficiencies will be noted by staff and emailed or faxed to the applicant and authorized agent at the end of the meeting, or shortly after. Administrative deficiencies will cause the application to be deemed incomplete and returned.

An appointment should be made to resubmit the application. The application is re-examined to ensure all deficiencies are resolved. The application will only be deemed administratively complete when all administrative deficiencies are addressed.

5. If an application is received by mail, courier service, or otherwise submitted without a review meeting, the administrative review will be conducted within 30 days. The applicant and agent will be contacted with the results of the administrative review. If the application is found to be administratively incomplete, it can be retrieved from the regional office or returned by regular mail. If returned by mail, the regional office may require arrangements for return shipping.
6. If the geologic assessment was completed before October 1, 2004 and the site contains “possibly sensitive” features, the assessment must be updated in accordance with the *Instructions to Geologists* (TCEQ-0585 Instructions).

Technical Review

1. When an application is deemed administratively complete, the technical review period begins. The regional office will distribute copies of the application to the identified affected city, county, and groundwater conservation district whose jurisdiction includes the subject site. These entities and the public have 30 days to provide comments on the application to the regional office. All comments received are reviewed by TCEQ.
2. A site assessment is usually conducted as part of the technical review, to evaluate the geologic assessment and observe existing site conditions. The site must be accessible to our staff. The site boundaries should be

clearly marked, features identified in the geologic assessment should be flagged, roadways marked and the alignment of the Sewage Collection System and manholes should be staked at the time the application is submitted. If the site is not marked the application may be returned.

3. We evaluate the application for technical completeness and contact the applicant and agent via Notice of Deficiency (NOD) to request additional information and identify technical deficiencies. There are two deficiency response periods available to the applicant. There are 14 days to resolve deficiencies noted in the first NOD. If a second NOD is issued, there is an additional 14 days to resolve deficiencies. If the response to the second notice is not received, is incomplete or inadequate, or provides new information that is incomplete or inadequate, the application must be withdrawn or will be denied. Please note that because the technical review is underway, whether the application is withdrawn or denied **the application fee will be forfeited.**
4. The program has 90 calendar days to complete the technical review of the application. If the application is technically adequate, such that it complies with the Edwards Aquifer rules, and is protective of the Edwards Aquifer during and after construction, an approval letter will be issued. Construction or other regulated activity may not begin until an approval is issued.

Mid-Review Modifications

It is important to have final site plans prior to beginning the permitting process with TCEQ to avoid delays.

Occasionally, circumstances arise where you may have significant design and/or site plan changes after your Edwards Aquifer application has been deemed administratively complete by TCEQ. This is considered a “Mid-Review Modification”. Mid-Review Modifications may require redistribution of an application that includes the proposed modifications for public comment.

If you are proposing a Mid-Review Modification, two options are available:

- If the technical review has begun your application can be denied/withdrawn, your fees will be forfeited, and the plan will have to be resubmitted.
- TCEQ can continue the technical review of the application as it was submitted, and a modification application can be submitted at a later time.

If the application is denied/withdrawn, the resubmitted application will be subject to the administrative and technical review processes and will be treated as a new application. The application will be redistributed to the affected jurisdictions.

Please contact the regional office if you have questions. If your project is located in Williamson, Travis, or Hays County, contact TCEQ’s Austin Regional Office at 512-339-2929. If your project is in Comal, Bexar, Medina, Uvalde, or Kinney County, contact TCEQ’s San Antonio Regional Office at 210-490-3096

Please fill out all required fields below and submit with your application.

1. Regulated Entity Name: Jade at Chisholm Trail				2. Regulated Entity No.:			
3. Customer Name: 2200 IH 35 RoundRock, LLC.				4. Customer No.:			
5. Project Type: (Please circle/check one)	<input checked="" type="radio"/> New	Modification		Extension		Exception	
6. Plan Type: (Please circle/check one)	<input checked="" type="radio"/> WPAP	<input type="radio"/> CZP	<input checked="" type="radio"/> SCS	<input type="radio"/> UST	<input type="radio"/> AST	<input type="radio"/> EXP	<input type="radio"/> EXT
7. Land Use: (Please circle/check one)	<input checked="" type="radio"/> Residential		Non-residential		8. Site (acres):		6.84
9. Application Fee:	\$5,650		10. Permanent BMP(s):		Jellyfish Units (2)		
11. SCS (Linear Ft.):	717		12. AST/UST (No. Tanks):				
13. County:	Williamson		14. Watershed:		Onion Branch		

Application Distribution

Instructions: Use the table below to determine the number of applications required. One original and one copy of the application, plus additional copies (as needed) for each affected incorporated city, county, and groundwater conservation district are required. Linear projects or large projects, which cross into multiple jurisdictions, can require additional copies. Refer to the “Texas Groundwater Conservation Districts within the EAPP Boundaries” map found at:

http://www.tceq.texas.gov/assets/public/compliance/field_ops/eapp/EAPP%20GWCD%20map.pdf

For more detailed boundaries, please contact the conservation district directly.

Austin Region			
County:	Hays	Travis	Williamson
Original (1 req.)	—	—	<u> </u> X <u> </u>
Region (1 req.)	—	—	<u> </u> X <u> </u>
County(ies)	—	—	<u> </u> X <u> </u>
Groundwater Conservation District(s)	<u> </u> Edwards Aquifer Authority <u> </u> Barton Springs/ Edwards Aquifer <u> </u> Hays Trinity <u> </u> Plum Creek	<u> </u> Barton Springs/ Edwards Aquifer	NA
City(ies) Jurisdiction	<u> </u> Austin <u> </u> Buda <u> </u> Dripping Springs <u> </u> Kyle <u> </u> Mountain City <u> </u> San Marcos <u> </u> Wimberley <u> </u> Woodcreek	<u> </u> Austin <u> </u> Bee Cave <u> </u> Pflugerville <u> </u> Rollingwood <u> </u> Round Rock <u> </u> Sunset Valley <u> </u> West Lake Hills	<u> </u> Austin <u> </u> Cedar Park <u> </u> Florence <u> </u> Georgetown <u> </u> Jerrell <u> </u> Leander <u> </u> Liberty Hill <u> </u> Pflugerville <u> </u> X Round Rock

San Antonio Region					
County:	Bexar	Comal	Kinney	Medina	Uvalde
Original (1 req.)	—	—	—	—	—
Region (1 req.)	—	—	—	—	—
County(ies)	—	—	—	—	—
Groundwater Conservation District(s)	<u> </u> Edwards Aquifer Authority <u> </u> Trinity-Glen Rose	<u> </u> Edwards Aquifer Authority	<u> </u> Kinney	<u> </u> EAA <u> </u> Medina	<u> </u> EAA <u> </u> Uvalde
City(ies) Jurisdiction	<u> </u> Castle Hills <u> </u> Fair Oaks Ranch <u> </u> Helotes <u> </u> Hill Country Village <u> </u> Hollywood Park <u> </u> San Antonio (SAWS) <u> </u> Shavano Park	<u> </u> Bulverde <u> </u> Fair Oaks Ranch <u> </u> Garden Ridge <u> </u> New Braunfels <u> </u> Schertz	NA	<u> </u> San Antonio ETJ (SAWS)	NA

I certify that to the best of my knowledge, that the application is complete and accurate. This application is hereby submitted to TCEQ for administrative review and technical review.

G. Robert Adams, PE

Print Name of Customer/Authorized Agent

G. Robert Adams

3.8.24

Signature of Customer/Authorized Agent

Date

****FOR TCEQ INTERNAL USE ONLY****

Date(s) Reviewed:		Date Administratively Complete:	
Received From:		Correct Number of Copies:	
Received By:		Distribution Date:	
EAPP File Number:		Complex:	
Admin. Review(s) (No.):		No. AR Rounds:	
Delinquent Fees (Y/N):		Review Time Spent:	
Lat./Long. Verified:		SOS Customer Verification:	
Agent Authorization Complete/Notarized (Y/N):		Fee Check:	Payable to TCEQ (Y/N):
Core Data Form Complete (Y/N):			Signed (Y/N):
Core Data Form Incomplete Nos.:			Less than 90 days old (Y/N):

General Information Form

Texas Commission on Environmental Quality

For Regulated Activities on the Edwards Aquifer Recharge and Transition Zones and Relating to 30 TAC §213.4(b) & §213.5(b)(2)(A), (B) Effective June 1, 1999

To ensure that the application is administratively complete, confirm that all fields in the form are complete, verify that all requested information is provided, consistently reference the same site and contact person in all forms in the application, and ensure forms are signed by the appropriate party.

Note: Including all the information requested in the form and attachments contributes to more streamlined technical reviews.

Signature

To the best of my knowledge, the responses to this form accurately reflect all information requested concerning the proposed regulated activities and methods to protect the Edwards Aquifer. This **General Information Form** is hereby submitted for TCEQ review. The application was prepared by:

Print Name of Customer/Agent: G. Robert Adams

Date: 3.8.24

Signature of Customer/Agent:



Project Information

1. Regulated Entity Name: Jade at Chisholm Trail
2. County: Williamson
3. Stream Basin: Onion Branch
4. Groundwater Conservation District (If applicable): _____

5. Edwards Aquifer Zone:

- Recharge Zone
 Transition Zone

6. Plan Type:

- WPAP
 SCS
 Modification
- AST
 UST
 Exception Request

7. Customer (Applicant):

Contact Person: Venkat Avasarala
Entity: 2200 IH 35 RoundRock, LLC.
Mailing Address: 6521 Hickory Hill Dr
City, State: Plano, Texas Zip: 75074
Telephone: 281-727-9238 FAX: _____
Email Address: Venkat@strykerprop.com

8. Agent/Representative (If any):

Contact Person: G. Robert Adams, PE
Entity: Langan Engineering
Mailing Address: 2999 Olympus Boulevard, Suite 165
City, State: Dallas, Texas Zip: 75019
Telephone: 817-328-3212 FAX: _____
Email Address: Radams@langan.com

9. Project Location:

- The project site is located inside the city limits of Round Rock.
- The project site is located outside the city limits but inside the ETJ (extra-territorial jurisdiction) of _____.
- The project site is not located within any city's limits or ETJ.

10. The location of the project site is described below. The description provides sufficient detail and clarity so that the TCEQ's Regional staff can easily locate the project and site boundaries for a field investigation.

Jade multi-family complex is bound by Chisholm Trail Road to the west, IH-35 frontage to the east, an existing commercial site to the north, and undeveloped land to the south. The site is located approximately 1,800 feet north of the intersection of Chisholm Trail Road and Chisholm Parkway.

11. **Attachment A – Road Map.** A road map showing directions to and the location of the project site is attached. The project location and site boundaries are clearly shown on the map.

12. **Attachment B - USGS / Edwards Recharge Zone Map.** A copy of the official 7 ½ minute USGS Quadrangle Map (Scale: 1" = 2000') of the Edwards Recharge Zone is attached. The map(s) clearly show:

- Project site boundaries.
- USGS Quadrangle Name(s).
- Boundaries of the Recharge Zone (and Transition Zone, if applicable).
- Drainage path from the project site to the boundary of the Recharge Zone.

13. **The TCEQ must be able to inspect the project site or the application will be returned.** Sufficient survey staking is provided on the project to allow TCEQ regional staff to locate

the boundaries and alignment of the regulated activities and the geologic or manmade features noted in the Geologic Assessment.

Survey staking will be completed by this date: _____

14. **Attachment C – Project Description.** Attached at the end of this form is a detailed narrative description of the proposed project. The project description is consistent throughout the application and contains, at a minimum, the following details:

- Area of the site
- Offsite areas
- Impervious cover
- Permanent BMP(s)
- Proposed site use
- Site history
- Previous development
- Area(s) to be demolished

15. Existing project site conditions are noted below:

- Existing commercial site
- Existing industrial site
- Existing residential site
- Existing paved and/or unpaved roads
- Undeveloped (Cleared)
- Undeveloped (Undisturbed/Uncleared)
- Other: _____

Prohibited Activities

16. I am aware that the following activities are prohibited on the Recharge Zone and are not proposed for this project:

- (1) Waste disposal wells regulated under 30 TAC Chapter 331 of this title (relating to Underground Injection Control);
- (2) New feedlot/concentrated animal feeding operations, as defined in 30 TAC §213.3;
- (3) Land disposal of Class I wastes, as defined in 30 TAC §335.1;
- (4) The use of sewage holding tanks as parts of organized collection systems; and
- (5) New municipal solid waste landfill facilities required to meet and comply with Type I standards which are defined in §330.41(b), (c), and (d) of this title (relating to Types of Municipal Solid Waste Facilities).
- (6) New municipal and industrial wastewater discharges into or adjacent to water in the state that would create additional pollutant loading.

17. I am aware that the following activities are prohibited on the Transition Zone and are not proposed for this project:

- (1) Waste disposal wells regulated under 30 TAC Chapter 331 (relating to Underground Injection Control);
- (2) Land disposal of Class I wastes, as defined in 30 TAC §335.1; and
- (3) New municipal solid waste landfill facilities required to meet and comply with Type I standards which are defined in §330.41 (b), (c), and (d) of this title.

Administrative Information

18. The fee for the plan(s) is based on:

- For a Water Pollution Abatement Plan or Modification, the total acreage of the site where regulated activities will occur.
- For an Organized Sewage Collection System Plan or Modification, the total linear footage of all collection system lines.
- For a UST Facility Plan or Modification or an AST Facility Plan or Modification, the total number of tanks or piping systems.
- A request for an exception to any substantive portion of the regulations related to the protection of water quality.
- A request for an extension to a previously approved plan.

19. Application fees are due and payable at the time the application is filed. If the correct fee is not submitted, the TCEQ is not required to consider the application until the correct fee is submitted. Both the fee and the Edwards Aquifer Fee Form have been sent to the Commission's:

- TCEQ cashier
- Austin Regional Office (for projects in Hays, Travis, and Williamson Counties)
- San Antonio Regional Office (for projects in Bexar, Comal, Kinney, Medina, and Uvalde Counties)

20. Submit one (1) original and one (1) copy of the application, plus additional copies as needed for each affected incorporated city, groundwater conservation district, and county in which the project will be located. The TCEQ will distribute the additional copies to these jurisdictions. The copies must be submitted to the appropriate regional office.

21. No person shall commence any regulated activity until the Edwards Aquifer Protection Plan(s) for the activity has been filed with and approved by the Executive Director.

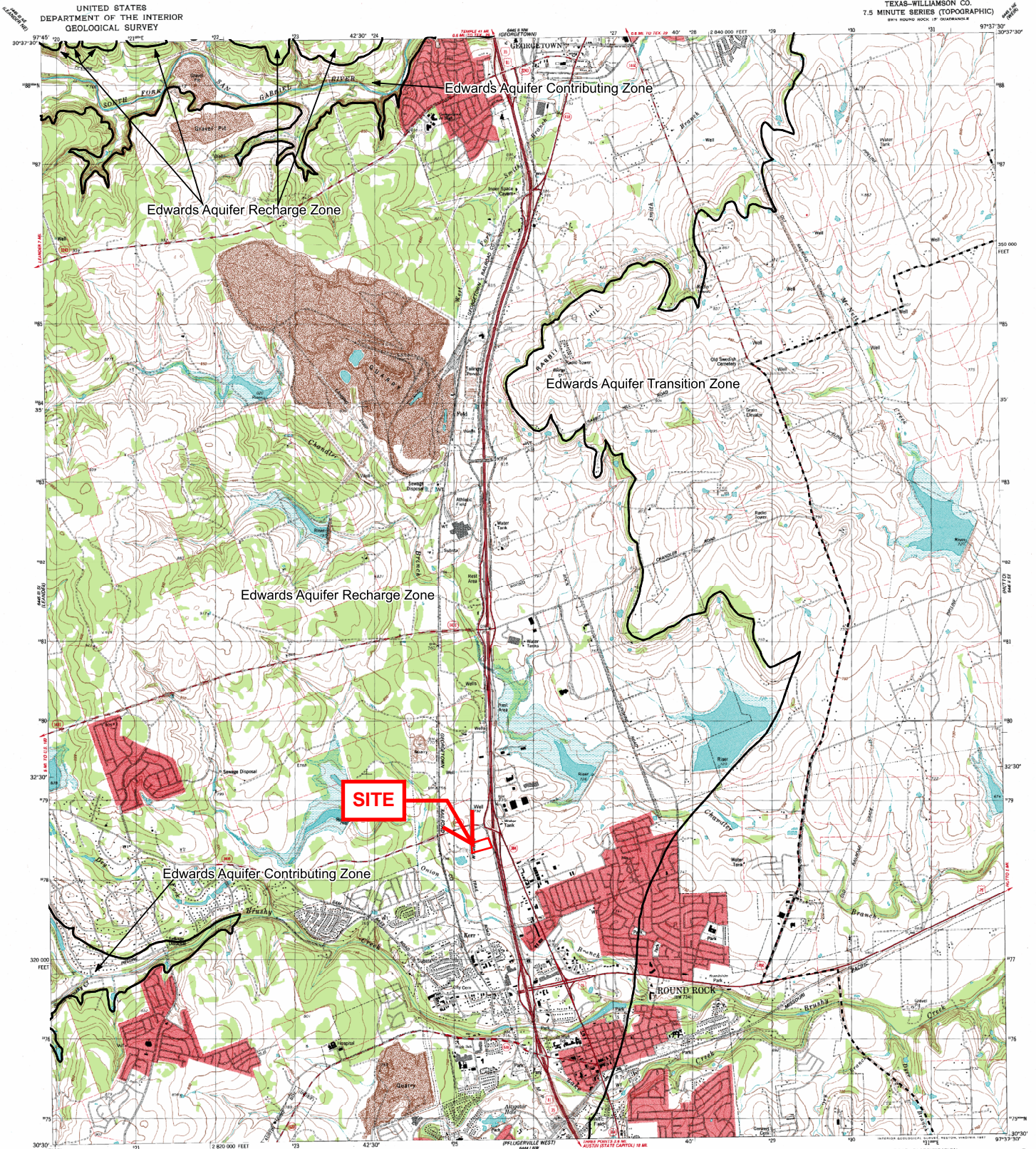

Mapped, edited and published by the Geological Survey
Control by USGS and NOS/NOAA

Topography by photogrammetric methods from aerial photographs taken 1974. Field checked 1975. Revised from aerial photographs taken 1985. Field checked 1986. Map edited 1987

Projection and 10,000-foot grid ticks: Texas coordinate system, central zone (Lambert conformal conic) 1000-meter Universal Transverse Mercator grid, zone 14 1927 North American Datum

To place on the predicted North America Datum 1983 move the projection lines 1.7 meters south and 28 meters east as shown by dashed corner ticks.

Fine red dashed lines indicate selected fence lines

Red tint indicates areas in which only landmark buildings are shown

Areas covered by dashed light-blue pattern are subject to controlled inundation

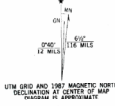

SCALE 1:24,000

CONTOUR INTERVAL 10 FEET
NATIONAL GEODETIC VERTICAL DATUM OF 1929

ROAD CLASSIFICATION

- Primary highway, hard surface
- Secondary highway, hard surface
- Unimproved road
- Interstate Route
- U. S. Route
- State Route



ROUND ROCK, TEXAS
3097-312

1987

DMA 6445 II SW-SERIES 1982



General Information TCEQ Form 0587

Attachment C: Project Description:

The proposed project, Jade at Chisholm Trail, is a multi-family residential building with on-site amenities to be built on a 6.83 acre site bounded by Chisolm Trail Road to the west, the IH-35 frontage road to the east, an existing commercial development to the north, and undeveloped land to the south. The site is located approximately 1,800 feet north of the intersection of Chisholm Trail Road and Chisholm Parkway in Round Rock, Texas 78681. The site is located within the Edwards Aquifer Recharge Zone

The existing site is undeveloped land. The site currently drains from the middle of the north side of the site to the southwest and to the southeast. The flow going to the southwest goes to an existing storm sewer system which discharges to Onion Branch which is in the Onion Branch watershed. Storm runoff that flows southeast goes to a drainage swale adjacent to the IH-35 frontage road and discharges to Onion Branch. There are no off-site areas draining through the site.

In the final constructed condition runoff from the site will be collected through use of area inlets, curb inlets, down spouts, and underground storm pipes. The storm pipes will route to two Jellyfish units, one on the north side of the building and one on the south. The Jellyfish units are the proposed BMPs to meet the water quality requirements of the recharge zone. Once through Jellyfish units storm runoff will be detained in an underground detention vault located within the building footprint. Runoff will then be routed to the existing storm infrastructure in Chisholm Trail Road.

There is no existing impervious cover on-site. In the proposed conditions the development will have surface parking, a four-story building apartment building, internal courtyards, and a parking structure in the middle of the building. The total impervious cover after the improvements will be 5.56 acres or 81.3% of the 6.84-acre site.

The construction activities for this site will also include construction of a sewage collection system consisting of approximately 717 linear feet of gravity sanitary line and three new manholes. The sanitary line will connect to an existing 8-inch gravity main in Chisholm Trail Road. The 8-inch line continues south to the intersection of Chisolm Trail Road and Chisholm Parkway at which point it increases in size to a 27-inch gravity main. The sewer lines flow to the Brushy Creek East Regional WWTP. Note the sewer line in Chisholm Trail Road currently has no flow as there are no developments utilizing it. We have confirmed this with the City of Round Rock and confirmed the sewer has capacity for the proposed development with a Wastewater Capacity Analysis which was approved by the City on 09 September 2022.



GEOLOGIC ASSESSMENT



Rowden Consulting, LLC
Environmental Services

Project:

Proposed Multi-Family Development
2200 N IH-35
Round Rock, Williamson Co., Texas

Prepared For:

Transcend Nirvana RR LLC
3 Sugar Creek Center Blvd, Ste 100
Sugar Land, TX 77478

Rowden Project No. 22.031

© April 5, 2022



Rowden Consulting, LLC
P.O. Box 978 • Bullard, TX 75757
903.894.6410

TABLE OF CONTENTS

INTRODUCTION 1

PROJECT DESCRIPTION..... 1

METHODS 1

PREVIOUS STUDIES AND APPROVALS 3

SITE GEOLOGY 3

SOILS 4

WATER WELLS 6

TOPOGRAPHY AND DRAINAGE..... 6

SITE ASSESSMENT RESULTS..... 7

SIGNATURE OF PROFESSIONAL GEOSCIENTIST 8

REFERENCES..... 9

APPENDICES

Appendix I Geologic Assessment Table

Appendix II Maps

Appendix III..... Photographs

Appendix IV TCEQ Form F-0585

INTRODUCTION

Rowden Consulting, LLC was retained by Langan to conduct this geologic assessment on behalf of Transcend Nirvana RR LLC. The study area includes approximately 6.8 acres of undeveloped land being planned for mixed-use and multi-family development in Round Rock, Williamson County, Texas. The primary purpose of this assessment was to evaluate the property for sensitive features, which are geologic or man-made features that could serve as pathways for contaminant movement to the Edwards Aquifer.

After conducting a literature and file review, a field evaluation was conducted to identify any potential occurrences of geologic or man-made features. The study area was evaluated for potential features including, but not limited to, closed depressions, sinkholes, caves, faults, fractures, bedding plane surfaces, interconnected vugs, reef deposits, wells, borings, and excavations which may have hydraulic interconnectedness between the surface and the Edwards Aquifer. The evaluation was conducted in accordance with the requirements of the Edwards Aquifer rules provided in 30 TAC Chapter 213. No sensitive features were identified by this assessment.

PROJECT DESCRIPTION

The property is comprised of approximately 6.8 acres of undeveloped land being planned for mixed-use and multi-family development. The property is bordered by commercial development to the north, Chisholm Trail Road to the west, North Interstate Highway 35 to the east, and undeveloped land to the south. The proposed development plan for the subject property had not been completed at the time this report was prepared. However, based on the size of the property, complete development of the tract is anticipated. Since no site plans were available, the Site Geologic Map in Appendix II may not match the scale of the site plan produced in the future by the site designer. If needed, a revised map can be provided in the future that matches the site plan scale.

The current plan for the property is to develop it for mixed-use and multi-family use. The development plan generally includes a multi-family building with a height of six stories covering an area of about 220,000 square feet. Between levels two and six, there will be an estimated 530 apartment units with a two-level parking structure on the lower floors. In addition, the development will include retail lease spaces, a swimming pool, parking and drives along with other amenities. At this time, there are no permanent stormwater controls in place on the property beyond soil conservation terraces installed sometime between 1954 and 1971. Proposed development plans must be completed before an application for a Water Pollution Abatement Plan can be submitted to the Texas Commission on Environmental Quality (TCEQ) for review and approval.

METHODS

This Geologic Assessment was conducted in accordance with the requirements of 30 TAC Chapter 213, including an implementation of the TCEQ-0585-Instructions document titled *Instructions to Geologists for Geologic Assessments on the Edwards Aquifer Recharge/Transition Zones Rev. 10-01-04*). The general procedure for conducting the geologic assessment was to perform the following steps: research information, perform a field survey, evaluate data, make conclusions, and provide a report with feature assessments and recommendations.

A Professional Geoscientist with Rowden Consulting, LLC walked parallel transects spaced fifty feet apart with a plan to map the locations of any sensitive or non-sensitive features using a handheld global positioning system (GPS), topographic maps, LIDAR maps, and aerial photographs. Closer spacing was used where trees, thick vegetation, or other objects inhibited clear observation. All observed features that could potentially exhibit karst characteristics were carefully examined for evidence of subsurface extent. Methods for exploring potential features included shallow hand excavation and probing with a soil probe and shovel to determine the characteristics of soil or fill material within suspect features. Types of vegetation present were noted and confirmation of animal burrows was made by observing the mounds and excavated soil along with the presence of bedding material, tracks, and other features produced by the activities of small mammals.

Features and transects were mapped in the field using a mapping grade global positioning (GPS) system. A Global Navigation Satellite System (GNSS) GPS receiver was used in the field. Real-time correction was utilized to attempt meter to submeter accuracy. Accuracy was closely monitored during fieldwork and critical data point collection was allowed to average over time until near or sub-meter results were achieved. The GNSS GPS is typically capable of producing one-meter positional accuracy using GPS, Precise Point Positioning (PPP), and Satellite-based Augmentation System (SBAS). PPP technology is made possible by stabilizing measurements of the distance between GNSS satellites and the receiver (pseudo-ranges) using carrier phase tracking. Additional accuracy is achieved from ionospheric correctional data received from satellite-based augmentation systems. Benchmark points were utilized to ensure accuracy at the beginning and end of the field day, and control points were carefully monitored with sufficient time to ensure that accuracy levels were acceptable for critical field shots.

The attached Geologic Assessment Table in Appendix I typically provides a description of features that meet the TCEQ definition of sensitive or nonsensitive features, where identified. However, no such features were identified by this assessment. Features that do not meet the TCEQ definition of potential features such as tree stump holes, surface weathering, karren, or animal burrows, were evaluated in the field and omitted from the table. To a limited degree, the geoscientist removed loose rocks and soil to preliminarily assess each potential feature's subsurface extent. No intensive excavation was conducted or required.

The results of this ground level survey do not preclude the possibility of finding subsurface voids or abandoned test or water wells during the clearing or construction phases of the proposed project. If a subsurface void is encountered during any phase of the project, construction should be halted and the TCEQ should be notified. Void closure plans may be required to resume development in such areas. Rowden Consulting, LLC recommends immediate contact and coordination with a geotechnical engineering consultant upon the discovery of any potential voids during construction.

PREVIOUS STUDIES AND APPROVALS

No prior studies or Geologic Assessments were identified for the subject property. Webb et al, of ECS Southwest, LLP, published a Geotechnical Engineering Report for the project dated February 17, 2022. ECS Southwest, LLP installed sixteen geotechnical soil borings on the property. The borings encountered fat clay from the surface to depths ranging from 2-4' below ground surface. Below this layer, they encountered clayey gravel, clayey sand, lean clay, gravelly lean clay, sandy lean clay, and sandy silty lean clay to depths ranging from 4-8.5' below ground surface. Limestone marl was encountered throughout the remaining depths of their borings. No borings encountered any groundwater that was confirmed. No void encounters or karst discoveries were made during their drilling beyond the reporting of fractured limestone well below the ground surface.

SITE GEOLOGY

According to the *Geological Atlas of Texas, Austin Sheet* (Barnes 1974. Reprinted 1981.), the property is located upon fluvial terrace deposits. These terraces along streams (Qt) consist of gravel, sand, silt, and clay in various proportions with mostly dolomite, limestone, and chert from the Edwards Plateau. In review of Housh, 2007, the fluvial terraces are estimated to be approximately 10-30' deep in the study area.

The Del Rio clay and Georgetown limestone, undivided formation extends around the mapped areas of fluvial terrace deposits, and likely underlies the deposits. The Del Rio clay is calcareous and gypsiferous, becoming less calcareous and more gypsiferous upward, pyrite common, blocky, medium gray, weathers light gray to yellowish gray; some thin lenticular beds of highly calcareous siltstone. The Georgetown Formation is comprised of limestone and marl; mostly limestone, fine grained, argillaceous, nodular, moderately indurated, light gray; some limestone, hard, brittle, thick bedded, white; some shale, marly, soft, light gray to yellowish gray; thickness 30-80 feet, thins southward (Barnes 1974. Reprinted 1981). Estimates of the thickness of the Del Rio clay Georgetown limestone, undivided formation are about 153' in the Round Rock Area (Housh, 2007).

A thin formation known as the Kiamichi formation typically exists below the Del Rio clay and Georgetown limestone, undivided formation in the area of Round Rock. The Kiamichi Formation is a light brown to gray, indistinctly bedded, argillaceous limestone, and it only has a thickness of about 4' in the area of Round Rock. (Housh 2007).

The Kiamichi Formation is underlain by the Edwards Formation in the area of Round Rock. The Edwards Formation is an aquifer sensitive to rapid recharge in the area. The Edwards Formation consists of massive limestone beds with bands of chert nodules and rudistid biostromes (Housh, 2007). The Edwards Formation is susceptible to chemical weathering processes and is typically vuggy where exposed. This porosity varies from the microscopic to the megascopic. Laubach Cave (Inner Space Caverns), which is present in the northern portion of the map area, is an excellent example of the degree to which the Edwards Formation is susceptible to major solution modification. Karst features are typically present wherever the Edwards Formation is present (Housh, 2007).

In the area of Round Rock, The Edwards Limestone is composed of about 210 feet of highly fractured and thickly bedded to massive limestone or dolomite, with minor shale, clay, and siliceous limestone. The Edwards Limestone is vuggy in places because of the occurrence of solution-collapse zones (Brune and Duffin, 1983). These zones, parallel to bedding planes, are the result of dissolution of gypsum beds that formerly occurred in this stratigraphic unit. They are cavernous and

iron stained and contain brecciated limestone, chert, crystalline calcite, and residual clay. These solution-collapse zones occur mainly 60 to 80 feet above the base of the Edwards Limestone, and are the main water-bearing horizons in the aquifer (Brune and Duffin, 1983). In addition to solution-collapse zones, groundwater in the Edwards aquifer flows through a network of steeply dipping faults and joints (Brune and Duffin, 1983).

Recharge to the Edwards and associated limestones results from infiltration of precipitation that falls on the outcrop of the aquifer or infiltration of runoff derived from watershed areas upstream from the aquifer outcrop. The recharge zone is characterized by the occurrence of numerous scattered karst features, such as dissolution-enhanced fractures, sinkholes, and caves, which are potential recharge sites (Jones 2003). Recharge also takes the form of infiltration along faults and joints that intersect losing segments of perennial and intermittent streams in the region. These fractures are often enlarged by karstification (Brune and Duffin, 1983).

In review of geologic resources along with detailed soil borings produced by geotechnical consultants (Webb et al 2022), no rock outcroppings occur on the property. Thick layers of clayey soils overlie other layers of soil with mixed textures. Bedrock is generally 4 to 8.5 feet below the ground surface. Most surface soils are clayey soils mapped as Hydrologic Group C or D soils. Based on this, rapid infiltration and karstification processes are unlikely to occur on the property.

SOILS

According to the U.S. Department of Agriculture *Web Soil Survey*, most of the study area is mapped within the Denton silty clay, 0 to 1 percent slopes and the Fairlie clay, 1 to 2 percent slopes soil series. A very small area of the property is mapped within the Denton silty clay, 1 to 3 percent slopes and the Georgetown stony clay loam, 1 to 3 percent slopes. The types of soil mapped on the property would not be expected to conduct significant amounts of surface water to the subsurface. Runoff is characterized as medium to very high for these map units. The following descriptive information was obtained from the *Web Soil Survey* for the mapped soil series:

Description of Denton (0-1% slopes)

Landform: Ridges

Parent material: Clayey slope alluvium and/or residuum over calcareous residuum weathered from limestone

Typical profile

Ap - 0 to 13 inches: silty clay

Bw - 13 to 19 inches: silty clay

2Bk - 19 to 36 inches: silt loam

2CBk - 36 to 52 inches: silt loam

2R - 52 to 80 inches: bedrock

Depth to restrictive feature: 40 to 60 inches to lithic bedrock

Drainage class: Well drained

Runoff class: Medium

Capacity of the most limiting layer to transmit water (Ksat): Moderately low to moderately high

Depth to water table: More than 80 inches

Frequency of flooding: None

Frequency of ponding: None

Hydrologic Soil Group: C

Description of Denton (1-3% slopes)

Landform: Hillslopes

Parent material: Silty and clayey slope alluvium over residuum weathered from limestone

Typical profile

A - 0 to 14 inches: silty clay

Bw - 14 to 25 inches: silty clay

Bk - 25 to 33 inches: silty clay

Ck - 33 to 36 inches: gravelly silty clay

R - 36 to 80 inches: bedrock

Depth to restrictive feature: 22 to 60 inches to lithic bedrock

Drainage class: Well drained

Runoff class: High

Capacity of the most limiting layer to transmit water (Ksat): Moderately low to moderately high

Depth to water table: More than 80 inches

Frequency of flooding: None

Frequency of ponding: None

Hydrologic Soil Group: D

Description of Fairlie

Landform: Ridges

Parent material: Residuum weathered from Austin chalk formation

Typical profile

H1 - 0 to 8 inches: clay

H2 - 8 to 46 inches: clay

H3 - 46 to 54 inches: bedrock

Depth to restrictive feature: 40 to 60 inches to paralithic bedrock

Drainage class: Moderately well drained

Runoff class: Very high

Capacity of the most limiting layer to transmit water (Ksat): Very low to moderately low

Depth to water table: More than 80 inches

Frequency of flooding: None

Frequency of ponding: None

Hydrologic Soil Group: D

Description of Georgetown

Landform: Ridges

Parent material: Clayey residuum weathered from limestone

Typical profile

A - 0 to 7 inches: stony clay loam

Bt - 7 to 35 inches: cobbly clay

R - 35 to 60 inches: bedrock

Depth to restrictive feature: 20 to 40 inches to lithic bedrock

Drainage class: Well drained

Runoff class: Very high

Capacity of the most limiting layer to transmit water (Ksat): Very low to moderately low

Depth to water table: More than 80 inches

Frequency of flooding: None

Frequency of ponding: None

Hydrologic Soil Group: D

WATER WELLS

No water wells were identified on the property. A review of database information provided by the Texas Water Development Board (TWDB) revealed no records of wells on or near the property. Several environmental test borings were drilled west of Chisholm Trail Road in 2016 by ACI Consulting. They generally encountered clayey soils at the surface.

TOPOGRAPHY AND DRAINAGE

The land surface is nearly level to gently sloping towards the south throughout the study area. No drainage features, channels, or streams were observed on the property. The terrain is generally flat without any areas of concentrated stormwater flow. Two large soil conservation terraces cross the property in an east-west direction. In review of the attached aerial photographs, the soil terraces appear to have been constructed between 1954 and 1971. Areas beyond the terraces were carefully observed for ponding and infiltration potential, and no significant areas were observed. On flat areas of the property, some minor evidence of small-scale ponding was observed following recent rainfalls. However, the surface soils were clayey in these areas and exhibited limited infiltration potential. Stormwater from heavy rains generally drains across the property in a sheetflow pattern. Runoff from the clayey surface soils would be high to very high, except for areas behind soil conservation terraces, which would slow runoff.

SITE ASSESSMENT RESULTS

No sensitive geologic features were identified in this study. Features observed are generally summarized in the following sections; however, the study area was generally found to be featureless. In general, the entire property was found to exhibit well developed, clayey soils with little to no rocks and no rock outcroppings. Very few animal burrows or other non-karst features were observed throughout the property.

SIGNATURE OF PROFESSIONAL GEOSCIENTIST

This Geologic Assessment has been prepared under the direction and supervision of the *Professional Geoscientist* undersigned below. The site reconnaissance, as well as review and interpretation of information upon which the report is based were all portions of the assessment performed by the undersigned.

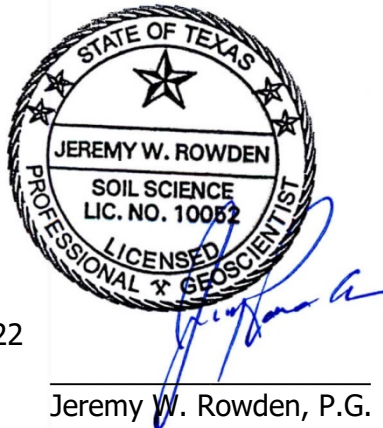

April 5, 2022

Jeremy W. Rowden, P.G.

REFERENCES

- Barnes, V.E. *Geologic Atlas of Texas, Austin Sheet*. Bureau of Economic Geology, The University of Texas at Austin. 1974. Reprinted 1981.
- Brune, Gunnar., and Gail L. Duffin. Occurrence, Availability, and Quality of Ground Water in Travis County, Texas. Report 276. Texas Department of Water Resources. June 1983.
- Dahl, S.L. Hydrogeology and stream interactions of the Edwards aquifer in the Salado Creek basin, Bell and Williamson Counties, central Texas: Baylor University, Master's thesis. 154 p. 1990.
- Housh, T.B. Bedrock Geology of Round Rock and Surrounding Areas, Williamson and Travis Counties, Texas. 2007.
- Webb, R.E. et al Geotechnical Engineering Report. Nirvana Mixed Use Multifamily Development. ECS Southwest, LLP. February 17, 2022.
- Jones, I.C. Groundwater Availability Modeling: Northern Segment of the Edwards Aquifer, Texas. Report 358. Texas Water Development Board. December 2003.
- Railroad Commission of Texas. RRC Public GIS Map Viewer. Webpage: <http://gis2.rrc.state.tx.us/public/startit.htm>. Accessed April 5, 2022.
- Rogers, C.W., Geologic map and structure section of Round Rock quadrangle, Williamson County, Texas. Austin, The University of Texas at Austin, M.A. thesis, 48p. 1963.
- Texas Commission on Environmental Quality (TCEQ), 1999, Complying with the Edwards Aquifer Rules: Administrative Guidance.
- TCEQ. Instructions to Geologists for completing Geologic Assessments within the Edwards Aquifer Recharge Zone. Revised October 2004.
- TCEQ, Edwards Aquifer Recharge Zone Boundary Maps. http://www.tceq.state.tx.us/compliance/field_ops/eapp/program.html. Accessed April 5, 2022.
- Texas Water Development Board. Water Data Interactive. Webpage: <http://www2.twdb.texas.gov/apps/waterdatainteractive/groundwaterdataviewer#>. Accessed April 5, 2022.
- United States Department of Agriculture. Web Soil Survey. <http://websoilsurvey.nrcs.usda.gov/app/WebSoilSurvey.aspx> Accessed April 5, 2022.

APPENDIX I
GEOLOGIC ASSESSMENT TABLE

**APPENDIX II
MAPS AND EXHIBITS**



Location Map

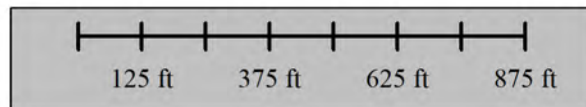

Rowden Consulting, LLC
Environmental Services

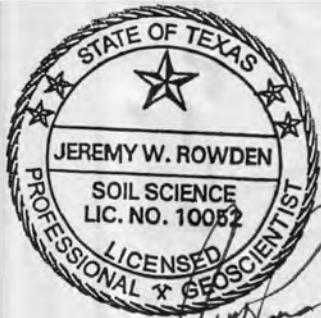

Jeremy W. Rowden
4/5/22

LEGEND

- Study Boundary
- Section Line
- Transect



Site Geologic Map

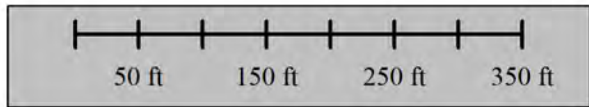

Rowden Consulting, LLC
Environmental Services

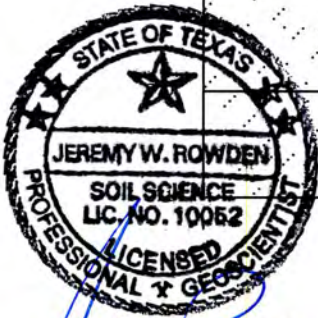
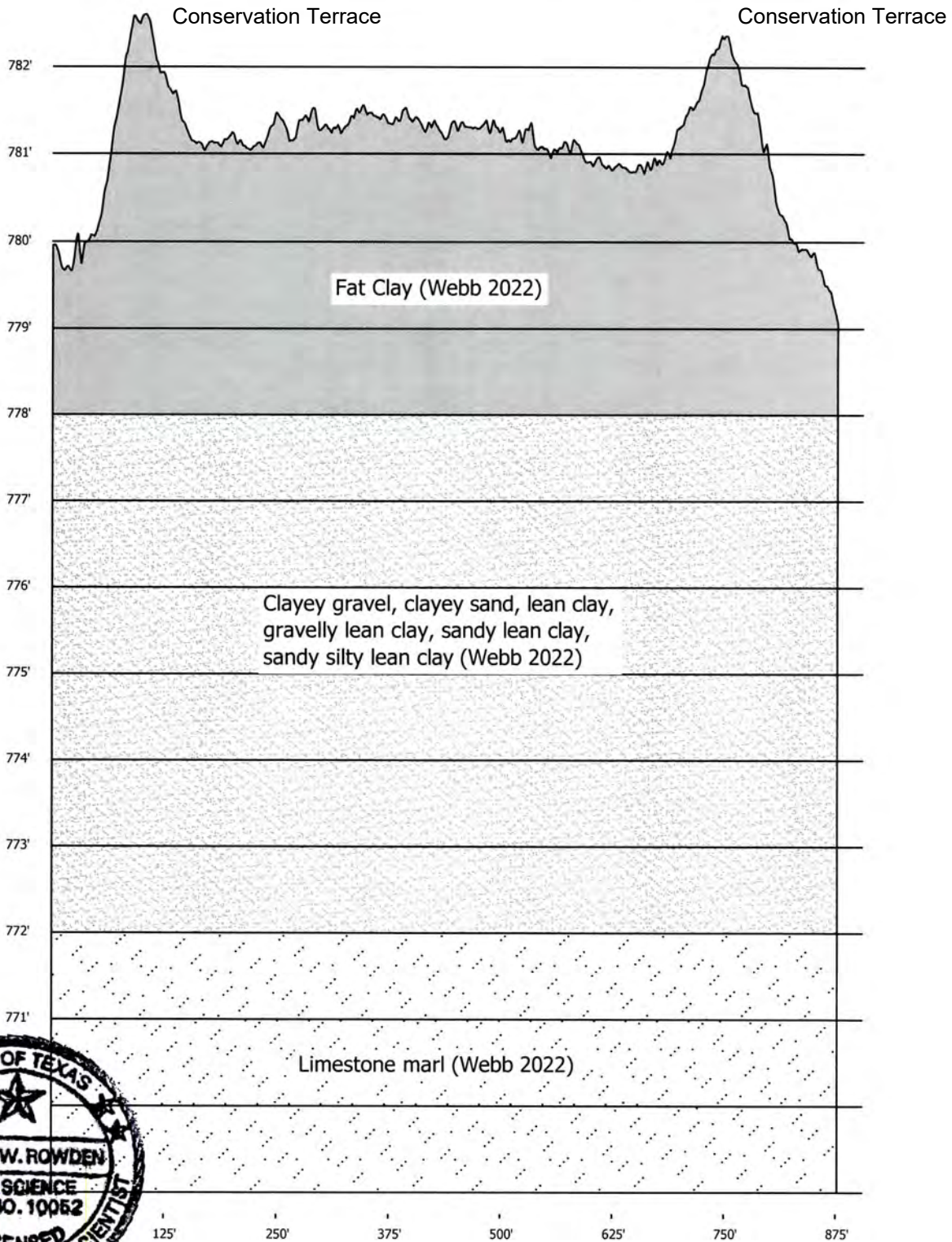

Jeremy Rowden
4/5/22

Section A - A'

Note: Generalized depths based on rough averages of depths observed from drilling by Webb et al 2022.

HORIZONTAL SCALE: 1" = 175'	Section A - A'	 Rowden Consulting, LLC Environmental Services P.O. Box 978 - Bullard, TX - 75757	PROJECT NO. 22.031
	Multi-Family Development Round Rock, Williamson Co., TX		DATE 4/5/22
			PROJECT MGR. jwr
			PROJECT TECH jwr

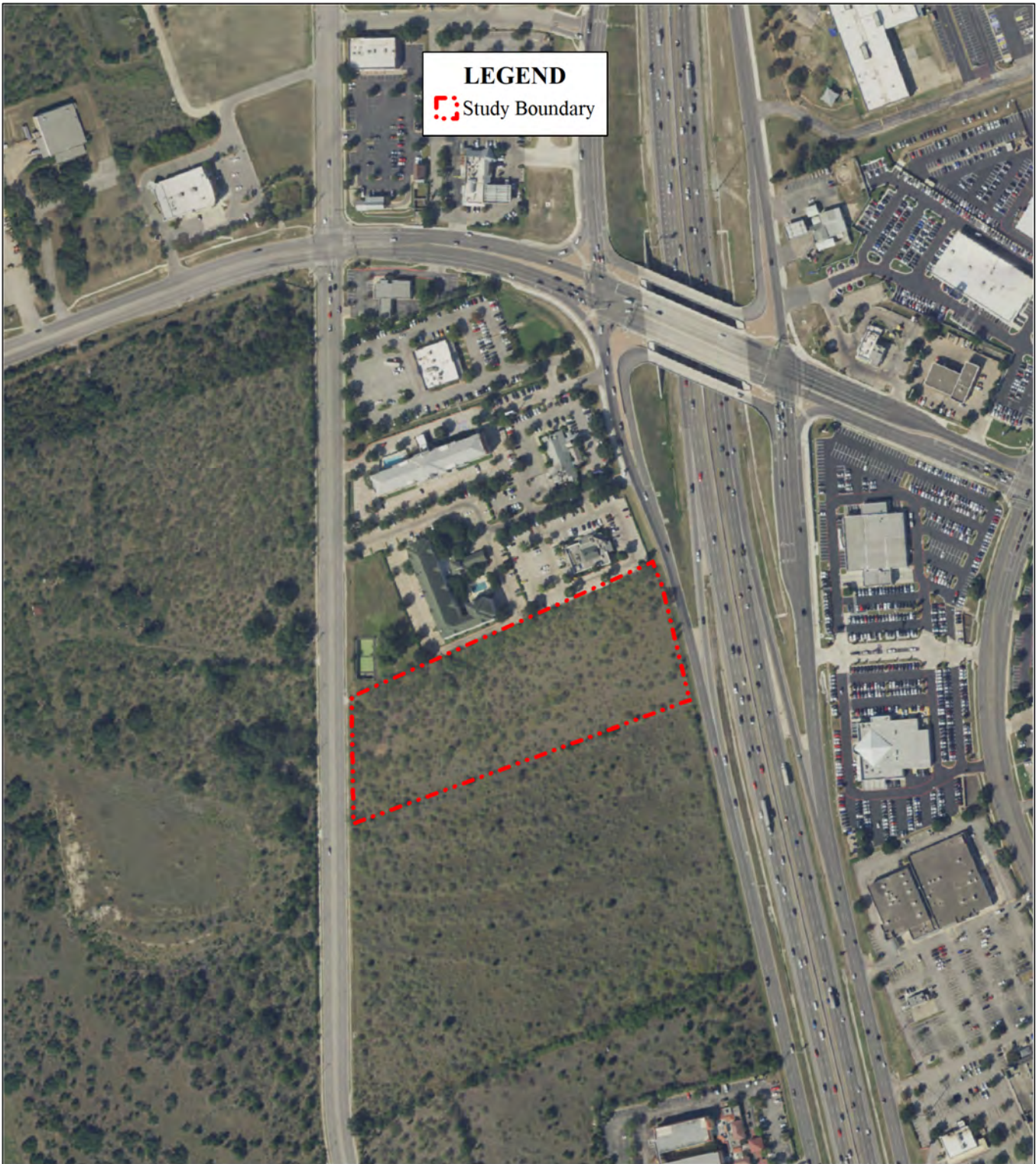

LEGEND
Study Boundary



2020 Aerial

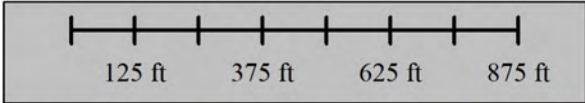

Rowden Consulting, LLC
Environmental Services

LEGEND
Study Boundary



1962 Aerial

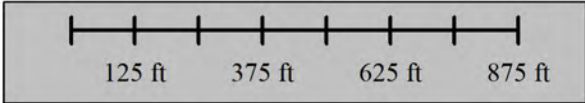

Rowden Consulting, LLC
Environmental Services

LEGEND
Study Boundary

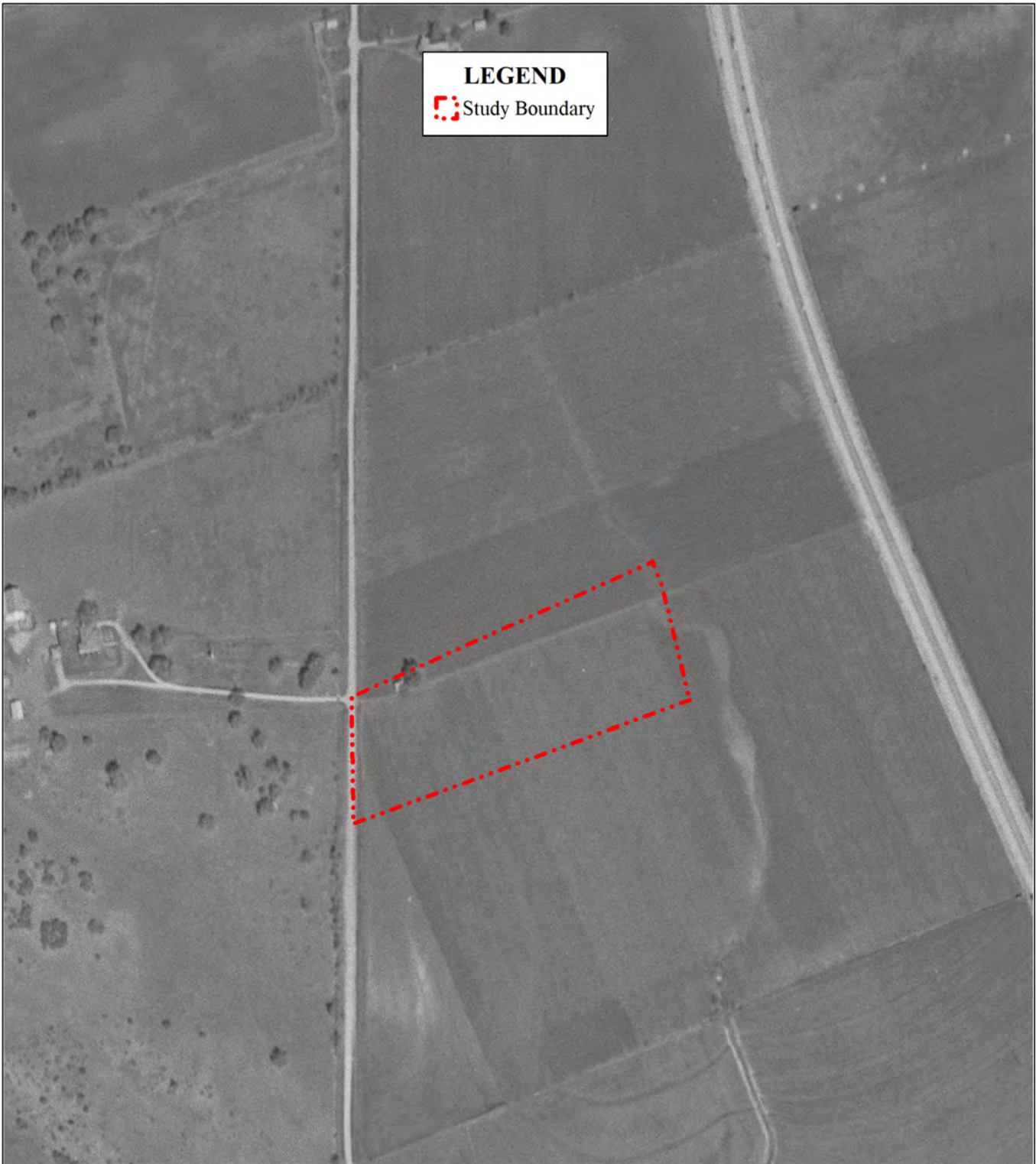

1954 Aerial

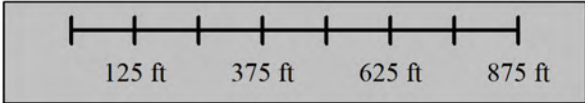

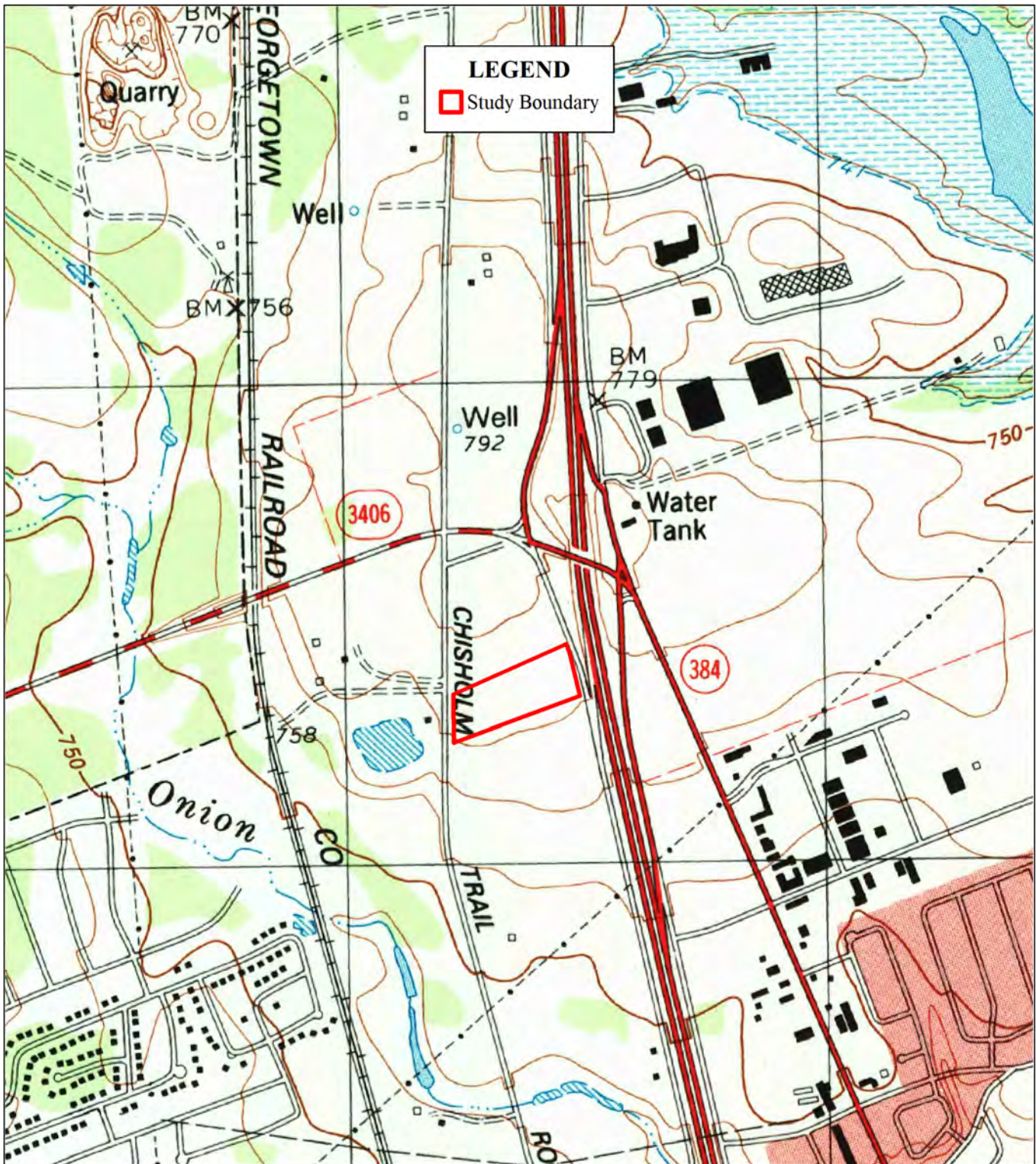

1987 USGS Topo Map
 (Round Rock Quad)

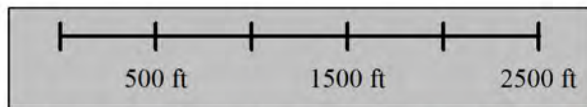

Rowden Consulting, LLC
 Environmental Services

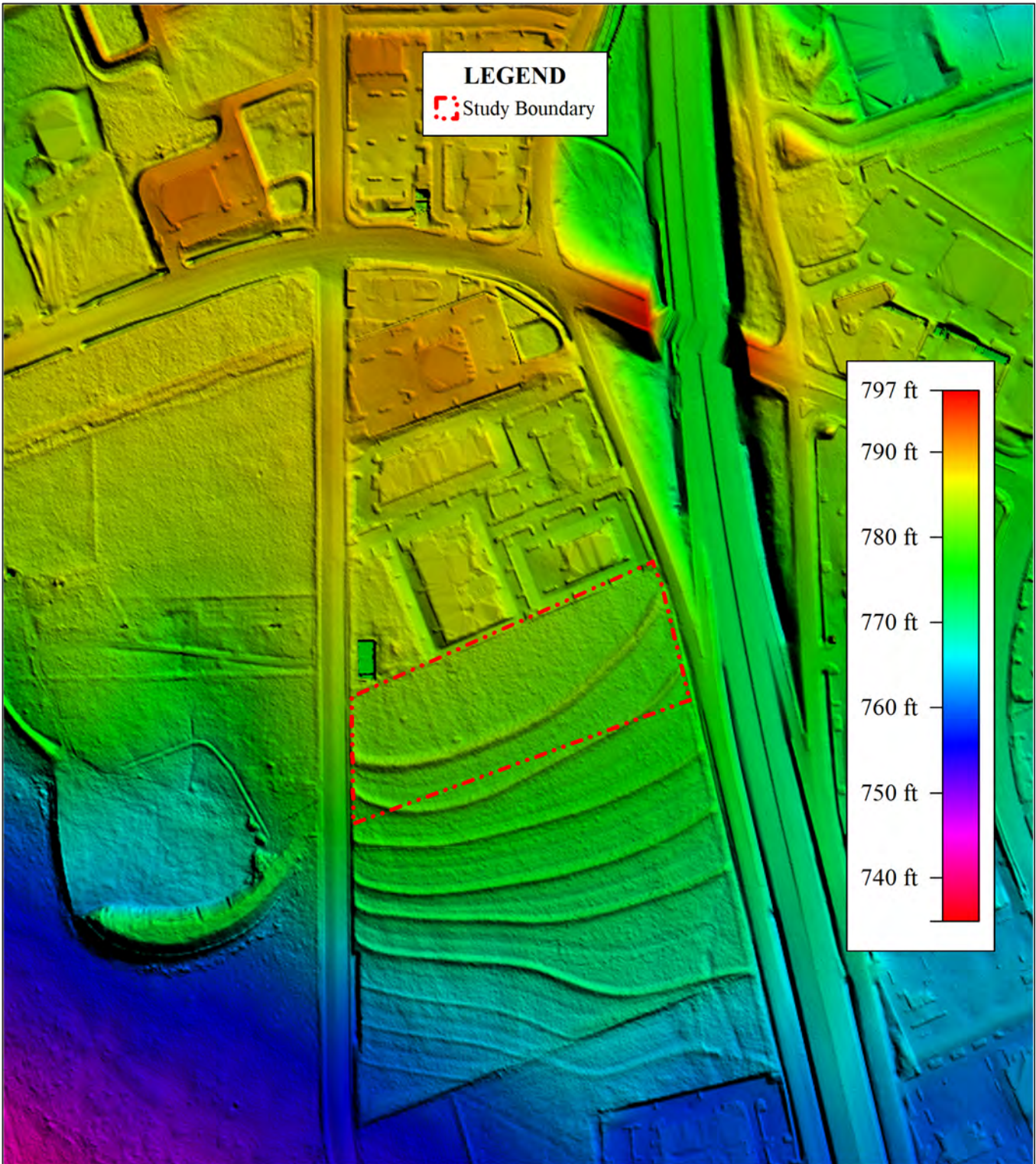

LEGEND
Study Boundary

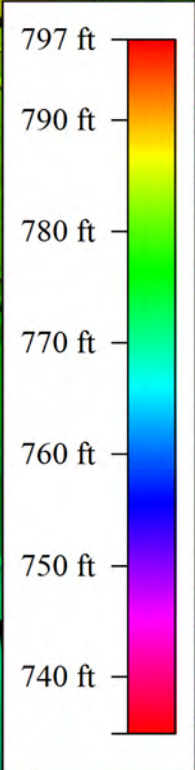

LIDAR Elevation Map

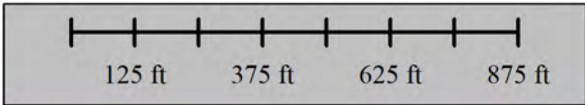

Rowden Consulting, LLC
Environmental Services

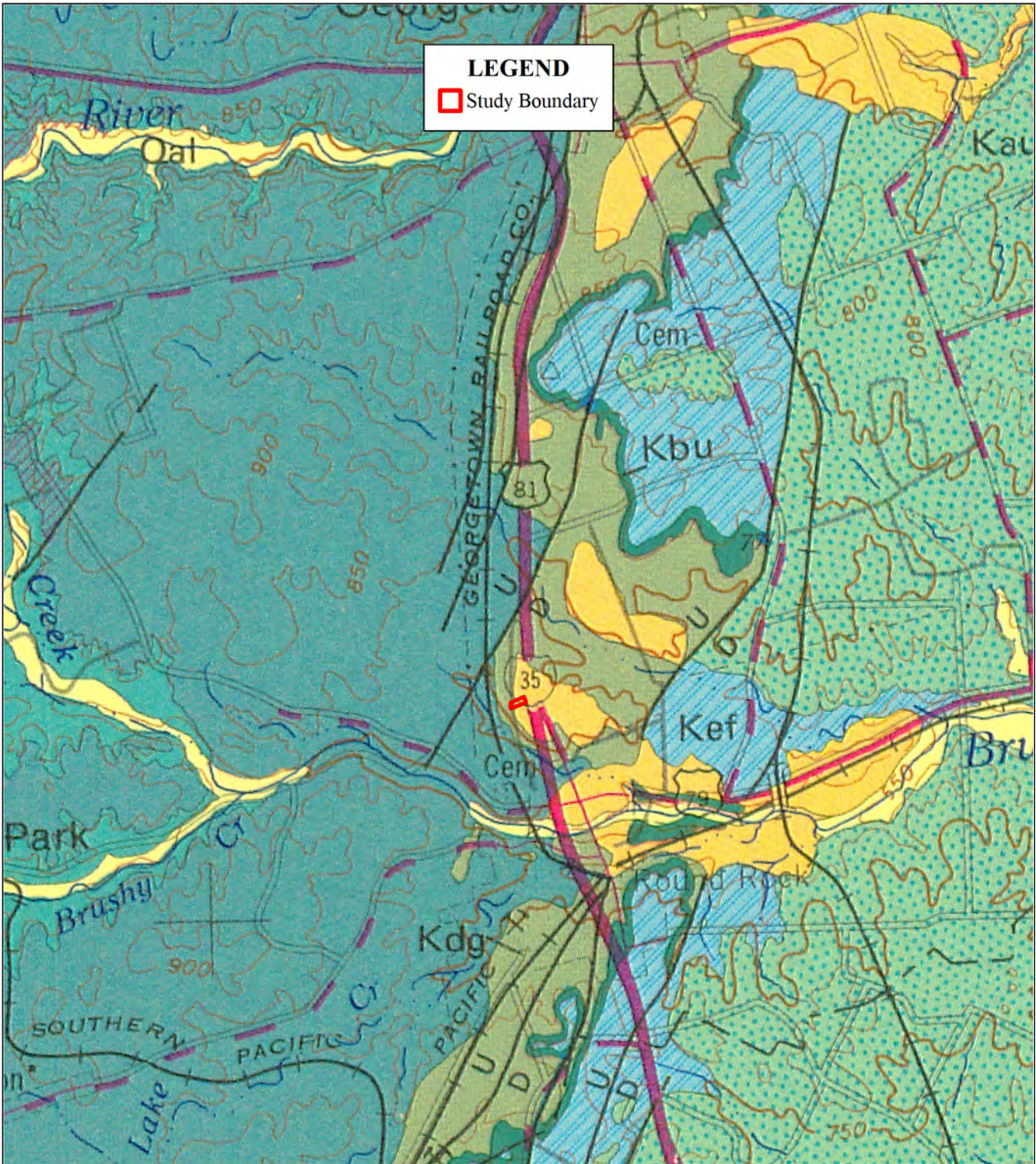

LEGEND
 □ Study Boundary

Geologic Atlas of Texas, Austin Sheet
 (BEG 1981)

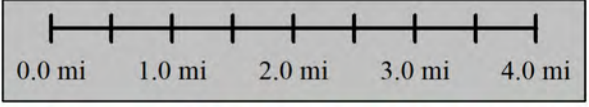

Rowden Consulting, LLC
 Environmental Services

Generalized Stratigraphic Column of the Round Rock Area

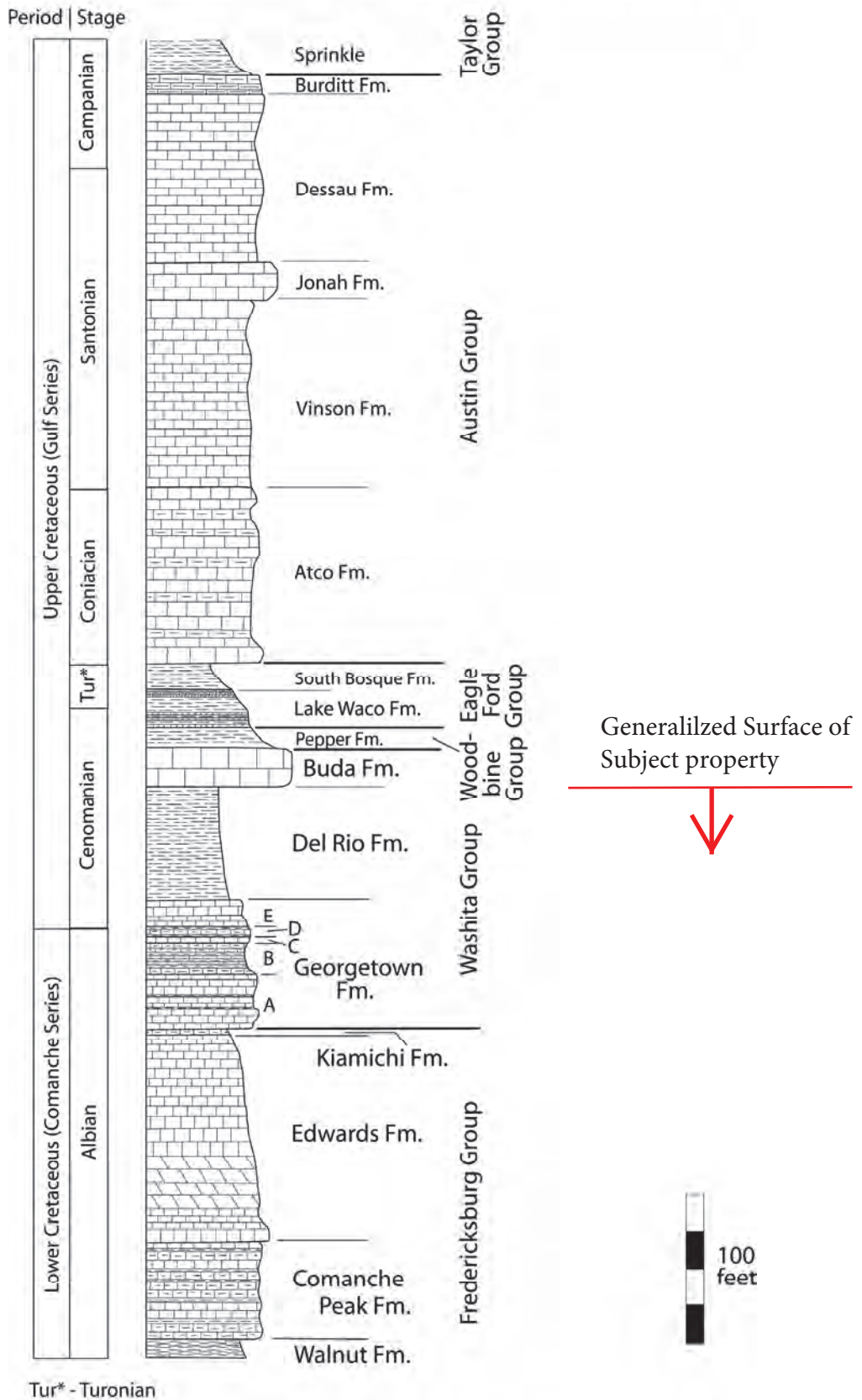

Source: Housh. 2007.

Stratigraphic Column
Round Rock Multi-Family Development

Period	Group or Formation	Thickness	Description
Quaternary	Fluviatile terrace deposits	~30' (varies)	These terraces along streams (Qt) consist of gravel, sand, silt, and clay in various proportions with dolomite, limestone, and chert from the Edwards Plateau (Barnes 1974. Reprinted 1981).
Cretaceous	Del Rio clay and Georgetown limestone, undivided	~153'	The Del Rio clay is calcareous and gypsiferous, becoming less calcareous and more gypsiferous upward, pyrite common, blocky, medium gray, weathers light gray to yellowish gray; some thin lenticular beds of highly calcareous siltstone. The Georgetown Formation is comprised of limestone and marl; mostly limestone, fine grained, argillaceous, nodular, moderately indurated, light gray; some limestone, hard, brittle, thick bedded, white; some shale, marly, soft, light gray to yellowish gray; thickness 30-80 feet, thins southward (Barnes 1974. Reprinted 1981).
Cretaceous	Kiamichi	~4'	The Kiamichi Formation is a light brown to gray, indistinctly bedded, argillaceous limestone. (Housh 2007).
Cretaceous	Edwards	~210'	The Edwards formation is comprised of limestone, dolomite, and chert; limestone aphanitic to fine grained, massive to thin bedded, hard, brittle, in part rudistid biostromes, much miliolid biosparite; dolomite fine to very fine grained, porous, medium gray to grayish brown; chert, nodules and plates common, varies in amount from bed to bed, some intervals free of chert, mostly white to light gray; in zone of weathering considerably recrystallized, "honeycombed," and cavernous forming an aquifer; forms flat areas and plateaus bordered by scarps; thickness 60-350 feet, thins northward (Barnes 1974. Reprinted 1981).



Jeremy W. Rowden
4/5/22

Hydrologic Soil Group—Williamson County, Texas
(RR)

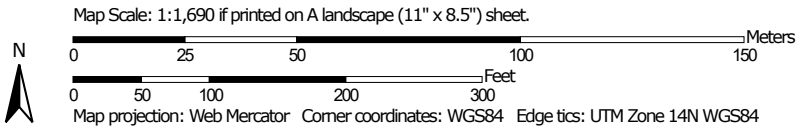

MAP LEGEND

Area of Interest (AOI)









 Area of Interest (AOI)

Soils

Soil Rating Polygons





 A
 A/D
 B
 B/D
 C
 C/D
 D
 Not rated or not available

Soil Rating Lines

 A
 A/D
 B
 B/D
 C
 C/D
 D
 Not rated or not available

Soil Rating Points





 A
 A/D
 B
 B/D

 C
 C/D
 D
 Not rated or not available

Water Features

 Streams and Canals

Transportation

 Rails
 Interstate Highways
 US Routes
 Major Roads
 Local Roads

Background

 Aerial Photography

MAP INFORMATION

The soil surveys that comprise your AOI were mapped at 1:20,000.

Warning: Soil Map may not be valid at this scale.

Enlargement of maps beyond the scale of mapping can cause misunderstanding of the detail of mapping and accuracy of soil line placement. The maps do not show the small areas of contrasting soils that could have been shown at a more detailed scale.

Please rely on the bar scale on each map sheet for map measurements.

Source of Map: Natural Resources Conservation Service
 Web Soil Survey URL:
 Coordinate System: Web Mercator (EPSG:3857)

Maps from the Web Soil Survey are based on the Web Mercator projection, which preserves direction and shape but distorts distance and area. A projection that preserves area, such as the Albers equal-area conic projection, should be used if more accurate calculations of distance or area are required.

This product is generated from the USDA-NRCS certified data as of the version date(s) listed below.

Soil Survey Area: Williamson County, Texas
 Survey Area Data: Version 22, Sep 10, 2021

Soil map units are labeled (as space allows) for map scales 1:50,000 or larger.

Date(s) aerial images were photographed: Nov 17, 2020—Dec 3, 2020

The orthophoto or other base map on which the soil lines were compiled and digitized probably differs from the background imagery displayed on these maps. As a result, some minor shifting of map unit boundaries may be evident.

Hydrologic Soil Group

Map unit symbol	Map unit name	Rating	Acres in AOI	Percent of AOI
DnA	Denton silty clay, 0 to 1 percent slopes	C	1.8	25.9%
DnB	Denton silty clay, 1 to 3 percent slopes	D	0.2	2.2%
FaB	Fairlie clay, 1 to 2 percent slopes	D	4.9	71.7%
GsB	Georgetown stony clay loam, 1 to 3 percent slopes	D	0.0	0.2%
Totals for Area of Interest			6.8	100.0%

Description

Hydrologic soil groups are based on estimates of runoff potential. Soils are assigned to one of four groups according to the rate of water infiltration when the soils are not protected by vegetation, are thoroughly wet, and receive precipitation from long-duration storms.

The soils in the United States are assigned to four groups (A, B, C, and D) and three dual classes (A/D, B/D, and C/D). The groups are defined as follows:

Group A. Soils having a high infiltration rate (low runoff potential) when thoroughly wet. These consist mainly of deep, well drained to excessively drained sands or gravelly sands. These soils have a high rate of water transmission.

Group B. Soils having a moderate infiltration rate when thoroughly wet. These consist chiefly of moderately deep or deep, moderately well drained or well drained soils that have moderately fine texture to moderately coarse texture. These soils have a moderate rate of water transmission.

Group C. Soils having a slow infiltration rate when thoroughly wet. These consist chiefly of soils having a layer that impedes the downward movement of water or soils of moderately fine texture or fine texture. These soils have a slow rate of water transmission.

Group D. Soils having a very slow infiltration rate (high runoff potential) when thoroughly wet. These consist chiefly of clays that have a high shrink-swell potential, soils that have a high water table, soils that have a claypan or clay layer at or near the surface, and soils that are shallow over nearly impervious material. These soils have a very slow rate of water transmission.

If a soil is assigned to a dual hydrologic group (A/D, B/D, or C/D), the first letter is for drained areas and the second is for undrained areas. Only the soils that in their natural condition are in group D are assigned to dual classes.

Rating Options

Aggregation Method: Dominant Condition

Component Percent Cutoff: None Specified

Tie-break Rule: Higher

**APPENDIX III
PHOTOGRAPHS**

Site Photos



General View

View of the property near the northwest corner facing east-southeast.



General View

View of the property near the southwest corner facing east-northeast.

Site Photos



Flat

View of flat area where shallow ponding may occur following rains. No evidence of karst features observed.



General View

View of mesquite thicket conditions along the north side of the property.

Site Photos



Plugged Boring

View of one of several plugged geotech borings observed on-site.



General View

View of the property from the eastern property line facing west.

APPENDIX IV
TCEQ FORM F-0585

Geologic Assessment

Texas Commission on Environmental Quality

For Regulated Activities on The Edwards Aquifer Recharge/transition Zones and Relating to 30 TAC §213.5(b)(3), Effective June 1, 1999

To ensure that the application is administratively complete, confirm that all fields in the form are complete, verify that all requested information is provided, consistently reference the same site and contact person in all forms in the application, and ensure forms are signed by the appropriate party.

Note: Including all the information requested in the form and attachments contributes to more streamlined technical reviews.

Signature

To the best of my knowledge, the responses to this form accurately reflect all information requested concerning the proposed regulated activities and methods to protect the Edwards Aquifer. My signature certifies that I am qualified as a geologist as defined by 30 TAC Chapter 213.

Print Name of Geologist: Jeremy Rowden

Telephone: (903) 894-6410

Date: 4/5/22

Fax: (903) 894-7511

Representing: Rowden Consulting, LLC #50394 (Name of Company and TBPG or TBPE registration number)

Signature of Geologist:

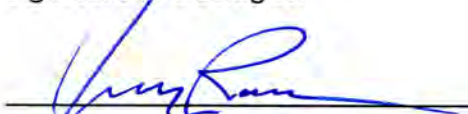

Regulated Entity Name: Transcend Nirvana RR LLC



Project Information

1. Date(s) Geologic Assessment was performed: 3/24/22

2. Type of Project:

WPAP

AST

SCS

UST

3. Location of Project:

Recharge Zone

Transition Zone

Contributing Zone within the Transition Zone

4. **Attachment A - Geologic Assessment Table.** Completed Geologic Assessment Table (Form TCEQ-0585-Table) is attached.
5. Soil cover on the project site is summarized in the table below and uses the SCS Hydrologic Soil Groups* (Urban Hydrology for Small Watersheds, Technical Release No. 55, Appendix A, Soil Conservation Service, 1986). If there is more than one soil type on the project site, show each soil type on the site Geologic Map or a separate soils map.

Table 1 - Soil Units, Infiltration Characteristics and Thickness

Soil Name	Group*	Thickness(feet)
Denton silty clay, 0 to 1 percent slopes	C	4.3
Denton silty clay, 1 to 3 percent slopes	D	3.0
Fairlie clay, 1 to 2 percent slopes	D	3.8
Georgetown stony clay loam, 1 to 3 percent slopes	D	2.9

Soil Name	Group*	Thickness(feet)

** Soil Group Definitions (Abbreviated)*

- A. Soils having a high infiltration rate when thoroughly wetted.
- B. Soils having a moderate infiltration rate when thoroughly wetted.
- C. Soils having a slow infiltration rate when thoroughly wetted.
- D. Soils having a very slow infiltration rate when thoroughly wetted.

6. **Attachment B – Stratigraphic Column.** A stratigraphic column showing formations, members, and thicknesses is attached. The outcropping unit, if present, should be at the top of the stratigraphic column. Otherwise, the uppermost unit should be at the top of the stratigraphic column.
7. **Attachment C – Site Geology.** A narrative description of the site specific geology including any features identified in the Geologic Assessment Table, a discussion of the potential for fluid movement to the Edwards Aquifer, stratigraphy, structure(s), and karst characteristics is attached.
8. **Attachment D – Site Geologic Map(s).** The Site Geologic Map must be the same scale as the applicant's Site Plan. The minimum scale is 1": 400'
 Applicant's Site Plan Scale: 1" = In Design'
 Site Geologic Map Scale: 1" = 150'
 Site Soils Map Scale (if more than 1 soil type): 1" = 141'
9. Method of collecting positional data:

- Global Positioning System (GPS) technology.
 Other method(s). Please describe method of data collection: _____
10. The project site and boundaries are clearly shown and labeled on the Site Geologic Map.
11. Surface geologic units are shown and labeled on the Site Geologic Map.
12. Geologic or manmade features were discovered on the project site during the field investigation. They are shown and labeled on the Site Geologic Map and are described in the attached Geologic Assessment Table.
- Geologic or manmade features were not discovered on the project site during the field investigation.
13. The Recharge Zone boundary is shown and labeled, if appropriate.
14. All known wells (test holes, water, oil, unplugged, capped and/or abandoned, etc.): If applicable, the information must agree with Item No. 20 of the WPAP Application Section.
- There are _____ (#) wells present on the project site and the locations are shown and labeled. (Check all of the following that apply.)
- The wells are not in use and have been properly abandoned.
- The wells are not in use and will be properly abandoned.
- The wells are in use and comply with 16 TAC Chapter 76.
- There are no wells or test holes of any kind known to exist on the project site.

Administrative Information

15. Submit one (1) original and one (1) copy of the application, plus additional copies as needed for each affected incorporated city, groundwater conservation district, and county in which the project will be located. The TCEQ will distribute the additional copies to these jurisdictions. The copies must be submitted to the appropriate regional office.

Water Pollution Abatement Plan Application

Texas Commission on Environmental Quality

for Regulated Activities on the Edwards Aquifer Recharge Zone and Relating to 30 TAC §213.5(b), Effective June 1, 1999

To ensure that the application is administratively complete, confirm that all fields in the form are complete, verify that all requested information is provided, consistently reference the same site and contact person in all forms in the application, and ensure forms are signed by the appropriate party.

Note: Including all the information requested in the form and attachments contributes to more streamlined technical reviews.

Signature

To the best of my knowledge, the responses to this form accurately reflect all information requested concerning the proposed regulated activities and methods to protect the Edwards Aquifer. This **Water Pollution Abatement Plan Application Form** is hereby submitted for TCEQ review and Executive Director approval. The form was prepared by:

Print Name of Customer/Agent: G. Robert Adams

Date: 3.8.24

Signature of Customer/Agent:

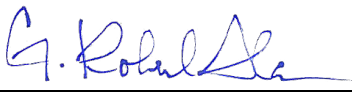

Regulated Entity Name: Jade at Chisholm Trail

Regulated Entity Information

1. The type of project is:

- Residential: Number of Lots: _____
- Residential: Number of Living Unit Equivalents: 196
- Commercial
- Industrial
- Other: _____

2. Total site acreage (size of property): 6.84

3. Estimated projected population: _____

4. The amount and type of impervious cover expected after construction are shown below:

Table 1 - Impervious Cover Table

Impervious Cover of Proposed Project	Sq. Ft.	Sq. Ft./Acre	Acres
Structures/Rooftops	169,903	÷ 43,560 =	3.90
Parking	61,843	÷ 43,560 =	1.42
Other paved surfaces	10,365	÷ 43,560 =	0.24
Total Impervious Cover	242,111	÷ 43,560 =	5.56

Total Impervious Cover $5.56 \div$ Total Acreage $6.84 \times 100 = 81.3\%$ Impervious Cover

5. **Attachment A - Factors Affecting Surface Water Quality.** A detailed description of all factors that could affect surface water and groundwater quality that addresses ultimate land use is attached.
6. Only inert materials as defined by 30 TAC §330.2 will be used as fill material.

For Road Projects Only

Complete questions 7 - 12 if this application is exclusively for a road project.

7. Type of project:
- TXDOT road project.
 - County road or roads built to county specifications.
 - City thoroughfare or roads to be dedicated to a municipality.
 - Street or road providing access to private driveways.
8. Type of pavement or road surface to be used:
- Concrete
 - Asphaltic concrete pavement
 - Other: _____
9. Length of Right of Way (R.O.W.): _____ feet.
 Width of R.O.W.: _____ feet.
 $L \times W =$ _____ $\text{Ft}^2 \div 43,560 \text{ Ft}^2/\text{Acre} =$ _____ acres.
10. Length of pavement area: _____ feet.
 Width of pavement area: _____ feet.
 $L \times W =$ _____ $\text{Ft}^2 \div 43,560 \text{ Ft}^2/\text{Acre} =$ _____ acres.
 Pavement area _____ acres \div R.O.W. area _____ acres $\times 100 =$ _____ % impervious cover.
11. A rest stop will be included in this project.
 A rest stop will not be included in this project.

12. Maintenance and repair of existing roadways that do not require approval from the TCEQ Executive Director. Modifications to existing roadways such as widening roads/adding shoulders totaling more than one-half (1/2) the width of one (1) existing lane require prior approval from the TCEQ.

Stormwater to be generated by the Proposed Project

13. **Attachment B - Volume and Character of Stormwater.** A detailed description of the volume (quantity) and character (quality) of the stormwater runoff which is expected to occur from the proposed project is attached. The estimates of stormwater runoff quality and quantity are based on the area and type of impervious cover. Include the runoff coefficient of the site for both pre-construction and post-construction conditions.

Wastewater to be generated by the Proposed Project

14. The character and volume of wastewater is shown below:

<u>100%</u> Domestic	<u>54,880</u> Gallons/day
<u> </u> % Industrial	<u> </u> Gallons/day
<u> </u> % Commingled	<u> </u> Gallons/day
TOTAL gallons/day <u>54,880</u>	

15. Wastewater will be disposed of by:

On-Site Sewage Facility (OSSF/Septic Tank):

Attachment C - Suitability Letter from Authorized Agent. An on-site sewage facility will be used to treat and dispose of the wastewater from this site. The appropriate licensing authority's (authorized agent) written approval is attached. It states that the land is suitable for the use of private sewage facilities and will meet or exceed the requirements for on-site sewage facilities as specified under 30 TAC Chapter 285 relating to On-site Sewage Facilities.

Each lot in this project/development is at least one (1) acre (43,560 square feet) in size. The system will be designed by a licensed professional engineer or registered sanitarian and installed by a licensed installer in compliance with 30 TAC Chapter 285.

Sewage Collection System (Sewer Lines):

Private service laterals from the wastewater generating facilities will be connected to an existing SCS.

Private service laterals from the wastewater generating facilities will be connected to a proposed SCS.

The SCS was previously submitted on _____.

The SCS was submitted with this application.

The SCS will be submitted at a later date. The owner is aware that the SCS may not be installed prior to Executive Director approval.

The sewage collection system will convey the wastewater to the Brushy Creek East Regional WWTP (name) Treatment Plant. The treatment facility is:

Existing.

Proposed.

16. All private service laterals will be inspected as required in 30 TAC §213.5.

Site Plan Requirements

Items 17 – 28 must be included on the Site Plan.

17. The Site Plan must have a minimum scale of 1" = 400'.

Site Plan Scale: 1" = 40'.

18. 100-year floodplain boundaries:

Some part(s) of the project site is located within the 100-year floodplain. The floodplain is shown and labeled.

No part of the project site is located within the 100-year floodplain.

The 100-year floodplain boundaries are based on the following specific (including date of material) sources(s): FEMA Firm No. 48491C0487F, last revised 20 December 2019

19. The layout of the development is shown with existing and finished contours at appropriate, but not greater than ten-foot contour intervals. Lots, recreation centers, buildings, roads, open space, etc. are shown on the plan.

The layout of the development is shown with existing contours at appropriate, but not greater than ten-foot intervals. Finished topographic contours will not differ from the existing topographic configuration and are not shown. Lots, recreation centers, buildings, roads, open space, etc. are shown on the site plan.

20. All known wells (oil, water, unplugged, capped and/or abandoned, test holes, etc.):

There are 0 (#) wells present on the project site and the locations are shown and labeled. (Check all of the following that apply)

The wells are not in use and have been properly abandoned.

The wells are not in use and will be properly abandoned.

The wells are in use and comply with 16 TAC §76.

There are no wells or test holes of any kind known to exist on the project site.

21. Geologic or manmade features which are on the site:

All sensitive geologic or manmade features identified in the Geologic Assessment are shown and labeled.

No sensitive geologic or manmade features were identified in the Geologic Assessment.

Attachment D - Exception to the Required Geologic Assessment. A request and justification for an exception to a portion of the Geologic Assessment is attached.

- 22. The drainage patterns and approximate slopes anticipated after major grading activities.
- 23. Areas of soil disturbance and areas which will not be disturbed.
- 24. Locations of major structural and nonstructural controls. These are the temporary and permanent best management practices.
- 25. Locations where soil stabilization practices are expected to occur.
- 26. Surface waters (including wetlands).
 - N/A
- 27. Locations where stormwater discharges to surface water or sensitive features are to occur.
 - There will be no discharges to surface water or sensitive features.
- 28. Legal boundaries of the site are shown.

Administrative Information

- 29. Submit one (1) original and one (1) copy of the application, plus additional copies as needed for each affected incorporated city, groundwater conservation district, and county in which the project will be located. The TCEQ will distribute the additional copies to these jurisdictions. The copies must be submitted to the appropriate regional office.
- 30. Any modification of this WPAP will require Executive Director approval, prior to construction, and may require submission of a revised application, with appropriate fees.

WPAP Application TCEQ Form 0584

Attachment A: Factors affecting surface water quality

The potential factors affecting **construction period surface water quality** from this site are: sediment runoff from disturbed areas, petroleum products runoff from drips from construction equipment, pesticides and fertilizers from landscaping activities, and high pH washwater from concrete and masonry cleanup/ washout facilities. Sediment runoff will be significantly reduced during construction by the use silt fences, inlet protection, and the Jellyfish units and detention vault permanent BMP. The high pH washwater potential will be controlled by requiring the use of appropriately sized, plastic-lined containment areas for concrete and masonry cement washout and cleanup activities. The petroleum and pesticide/ fertilizer sources will be minimized by the use of good housekeeping procedures and inspections by trained personnel to ensure that all construction activities follow the procedures given in the Temporary Stormwater Section prepared for the site.

The potential factors affecting **post-construction surface water quality** from this site are: pesticide and fertilizer runoff from vegetated areas, petroleum products runoff from parking areas and drives. Sediment runoff from the site will be significantly reduced by the action of the permanent BMP. Pesticide/ fertilizer runoff will be minimized by education of the maintenance staff or outside landscaping firm relative to acceptable landscaping practices after construction activities are completed.

WPAP Application TCEQ Form 0584

Attachment B: Quantity and quality of stormwater runoff expected to occur on the site.

Please refer to Plan Sheets C6.00 (Existing Drainage Area Map) and C6.01 (Proposed Drainage Area Map) of the Construction plans for more details on the information presented below.

Pre-construction conditions: The drainage area is 6.84 acres. No off-site stormwater runoff from the north will route through the site. Please see the existing drainage area map shown on plan sheet C6.00. Total calculated discharge rate for the on-site drainage area is as follows (calculations are based on the Rational Method $Q = C \cdot I \cdot A$, as presented in the City of Round Rock Design and Construction Standards, Drainage Specifications; total peak discharge rate is calculated using the Time of Concentration values shown below):

PRE-DEVELOPMENT DRAINAGE AREA CALCULATIONS														
Drainage Area Designation	Drainage Area	Runoff Coefficient "C"				Time of Concentration	2-Year	2-Year	10-Year	10-Year	25-Year	25-Year	100-Year	100-Year
		2- Yr	10- Yr	25- Yr	100- Yr		Rainfall Intensity (I2)	Peak Discharge (Q2)	Rainfall Intensity (I10)	Peak Discharge (Q10)	Rainfall Intensity (I25)	Peak Discharge (Q25)	Rainfall Intensity (I100)	Peak Discharge (Q100)
-	(ac)				(min)	(in/hr)	(cfs)	(in/hr)	(cfs)	(in/hr)	(cfs)	(in/hr)	(cfs)	
EX-1	2.71	0.35	0.41	0.44	0.51	14	4.40	4.17	6.57	7.29	8.07	9.62	10.63	14.68
EX-2	4.13	0.35	0.41	0.44	0.51	9	5.27	7.62	7.88	13.35	9.69	17.60	12.74	26.85
Total	6.84							11.79		20.64		27.23		41.53

Note: Calculations based on the Rational Method: $Q = C \cdot I \cdot A$ per the 2020 Round Rock Drainage Criteria Manual

Post-construction conditions: The peak discharge rates for post-construction are increased leaving the site due to the site improvements/impervious cover. Runoff rates are mitigated by the below grade detention vault and reduced to below existing conditions. The direct runoff summary from the site is shown below.

PEAK DISCHARGE AT DESIGN POINT										
Design Point	Existing Conditions					Comments	Proposed Conditions			
	2-Year	10-Year	25-Year	100-Year	2-Year		10-Year	25-Year	100-Year	
	(cfs)	(cfs)	(cfs)	(cfs)	(cfs)		(cfs)	(cfs)	(cfs)	
1	4.17	7.29	9.62	14.68	X-1	13.03	20.11	25.49	32.52	Includes Undetained Flows
2	7.62	13.35	17.60	26.85	X-2	0.00	0.00	0.00	0.00	
	11.79	20.64	27.23	41.53	Total	13.03	20.11	25.49	32.52	Total

Temporary Stormwater Section

Texas Commission on Environmental Quality

for Regulated Activities on the Edwards Aquifer Recharge Zone and Relating to 30 TAC §213.5(b)(4)(A), (B), (D)(I) and (G); Effective June 1, 1999

To ensure that the application is administratively complete, confirm that all fields in the form are complete, verify that all requested information is provided, consistently reference the same site and contact person in all forms in the application, and ensure forms are signed by the appropriate party.

Note: Including all the information requested in the form and attachments contributes to more streamlined technical reviews.

Signature

To the best of my knowledge, the responses to this form accurately reflect all information requested concerning the proposed regulated activities and methods to protect the Edwards Aquifer. This **Temporary Stormwater Section** is hereby submitted for TCEQ review and executive director approval. The application was prepared by:

Print Name of Customer/Agent: G. Robert Adams, PE

Date: 3.8.24

Signature of Customer/Agent:



Regulated Entity Name: Jade at Chisholm Trail

Project Information

Potential Sources of Contamination

Examples: Fuel storage and use, chemical storage and use, use of asphaltic products, construction vehicles tracking onto public roads, and existing solid waste.

1. Fuels for construction equipment and hazardous substances which will be used during construction:

The following fuels and/or hazardous substances will be stored on the site: _____

These fuels and/or hazardous substances will be stored in:

- Aboveground storage tanks with a cumulative storage capacity of less than 250 gallons will be stored on the site for less than one (1) year.

- Aboveground storage tanks with a cumulative storage capacity between 250 gallons and 499 gallons will be stored on the site for less than one (1) year.
- Aboveground storage tanks with a cumulative storage capacity of 500 gallons or more will be stored on the site. An Aboveground Storage Tank Facility Plan application must be submitted to the appropriate regional office of the TCEQ prior to moving the tanks onto the project.
- Fuels and hazardous substances will not be stored on the site.
- 2. **Attachment A - Spill Response Actions.** A site specific description of the measures to be taken to contain any spill of hydrocarbons or hazardous substances is attached.
- 3. Temporary aboveground storage tank systems of 250 gallons or more cumulative storage capacity must be located a minimum horizontal distance of 150 feet from any domestic, industrial, irrigation, or public water supply well, or other sensitive feature.
- 4. **Attachment B - Potential Sources of Contamination.** A description of any activities or processes which may be a potential source of contamination affecting surface water quality is attached.

Sequence of Construction

- 5. **Attachment C - Sequence of Major Activities.** A description of the sequence of major activities which will disturb soils for major portions of the site (grubbing, excavation, grading, utilities, and infrastructure installation) is attached.
 - For each activity described, an estimate (in acres) of the total area of the site to be disturbed by each activity is given.
 - For each activity described, include a description of appropriate temporary control measures and the general timing (or sequence) during the construction process that the measures will be implemented.
- 6. Name the receiving water(s) at or near the site which will be disturbed or which will receive discharges from disturbed areas of the project: Onion Branch

Temporary Best Management Practices (TBMPs)

Erosion control examples: tree protection, interceptor swales, level spreaders, outlet stabilization, blankets or matting, mulch, and sod. Sediment control examples: stabilized construction exit, silt fence, filter dikes, rock berms, buffer strips, sediment traps, and sediment basins. Please refer to the Technical Guidance Manual for guidelines and specifications. All structural BMPs must be shown on the site plan.

- 7. **Attachment D – Temporary Best Management Practices and Measures.** TBMPs and measures will prevent pollution of surface water, groundwater, and stormwater. The construction-phase BMPs for erosion and sediment controls have been designed to retain sediment on site to the extent practicable. The following information is attached:

- A description of how BMPs and measures will prevent pollution of surface water, groundwater or stormwater that originates upgradient from the site and flows across the site.
 - A description of how BMPs and measures will prevent pollution of surface water or groundwater that originates on-site or flows off site, including pollution caused by contaminated stormwater runoff from the site.
 - A description of how BMPs and measures will prevent pollutants from entering surface streams, sensitive features, or the aquifer.
 - A description of how, to the maximum extent practicable, BMPs and measures will maintain flow to naturally-occurring sensitive features identified in either the geologic assessment, TCEQ inspections, or during excavation, blasting, or construction.
8. The temporary sealing of a naturally-occurring sensitive feature which accepts recharge to the Edwards Aquifer as a temporary pollution abatement measure during active construction should be avoided.
- Attachment E - Request to Temporarily Seal a Feature.** A request to temporarily seal a feature is attached. The request includes justification as to why no reasonable and practicable alternative exists for each feature.
 - There will be no temporary sealing of naturally-occurring sensitive features on the site.
9. **Attachment F - Structural Practices.** A description of the structural practices that will be used to divert flows away from exposed soils, to store flows, or to otherwise limit runoff discharge of pollutants from exposed areas of the site is attached. Placement of structural practices in floodplains has been avoided.
10. **Attachment G - Drainage Area Map.** A drainage area map supporting the following requirements is attached:
- For areas that will have more than 10 acres within a common drainage area disturbed at one time, a sediment basin will be provided.
 - For areas that will have more than 10 acres within a common drainage area disturbed at one time, a smaller sediment basin and/or sediment trap(s) will be used.
 - For areas that will have more than 10 acres within a common drainage area disturbed at one time, a sediment basin or other equivalent controls are not attainable, but other TBMPs and measures will be used in combination to protect down slope and side slope boundaries of the construction area.
 - There are no areas greater than 10 acres within a common drainage area that will be disturbed at one time. A smaller sediment basin and/or sediment trap(s) will be used in combination with other erosion and sediment controls within each disturbed drainage area.

- There are no areas greater than 10 acres within a common drainage area that will be disturbed at one time. Erosion and sediment controls other than sediment basins or sediment traps within each disturbed drainage area will be used.
11. **Attachment H - Temporary Sediment Pond(s) Plans and Calculations.** Temporary sediment pond or basin construction plans and design calculations for a proposed temporary BMP or measure have been prepared by or under the direct supervision of a Texas Licensed Professional Engineer. All construction plans and design information must be signed, sealed, and dated by the Texas Licensed Professional Engineer. Construction plans for the proposed temporary BMPs and measures are attached.
- N/A
12. **Attachment I - Inspection and Maintenance for BMPs.** A plan for the inspection of each temporary BMP(s) and measure(s) and for their timely maintenance, repairs, and, if necessary, retrofit is attached. A description of the documentation procedures, recordkeeping practices, and inspection frequency are included in the plan and are specific to the site and/or BMP.
13. All control measures must be properly selected, installed, and maintained in accordance with the manufacturer's specifications and good engineering practices. If periodic inspections by the applicant or the executive director, or other information indicate a control has been used inappropriately, or incorrectly, the applicant must replace or modify the control for site situations.
14. If sediment escapes the construction site, off-site accumulations of sediment must be removed at a frequency sufficient to minimize offsite impacts to water quality (e.g., fugitive sediment in street being washed into surface streams or sensitive features by the next rain).
15. Sediment must be removed from sediment traps or sedimentation ponds not later than when design capacity has been reduced by 50%. A permanent stake will be provided that can indicate when the sediment occupies 50% of the basin volume.
16. Litter, construction debris, and construction chemicals exposed to stormwater shall be prevented from becoming a pollutant source for stormwater discharges (e.g., screening outfalls, picked up daily).

Soil Stabilization Practices

Examples: establishment of temporary vegetation, establishment of permanent vegetation, mulching, geotextiles, sod stabilization, vegetative buffer strips, protection of trees, or preservation of mature vegetation.

17. **Attachment J - Schedule of Interim and Permanent Soil Stabilization Practices.** A schedule of the interim and permanent soil stabilization practices for the site is attached.

18. Records must be kept at the site of the dates when major grading activities occur, the dates when construction activities temporarily or permanently cease on a portion of the site, and the dates when stabilization measures are initiated.
19. Stabilization practices must be initiated as soon as practicable where construction activities have temporarily or permanently ceased.

Administrative Information

20. All structural controls will be inspected and maintained according to the submitted and approved operation and maintenance plan for the project.
21. If any geologic or manmade features, such as caves, faults, sinkholes, etc., are discovered, all regulated activities near the feature will be immediately suspended. The appropriate TCEQ Regional Office shall be immediately notified. Regulated activities must cease and not continue until the TCEQ has reviewed and approved the methods proposed to protect the aquifer from any adverse impacts.
22. Silt fences, diversion berms, and other temporary erosion and sediment controls will be constructed and maintained as appropriate to prevent pollutants from entering sensitive features discovered during construction.

Temporary Stormwater Management Practices TCEQ Form 0602

Attachment A Spill Response Actions

SPILL PREVENTION CONTROL AND COUNTERMEASURES (SPCC) PLAN

1 MATERIALS COVERED

The following materials or substances with known hazardous properties are expected to be present onsite during construction:

Concrete	Cleaning solvents
Detergents	Petroleum based products
Paints	Pesticides
Paint solvents	Acids
Fertilizers	Concrete additives
Soil stabilization additives	

2 MATERIAL MANAGEMENT PRACTICES

The following are the material management practices that will be used to reduce the risk of spills or other accidental exposure of materials and substances to stormwater runoff.

2.1 Good Housekeeping

The following good housekeeping practices will be followed onsite during the construction project.

- A. An effort will be made to store only enough product required to do the job.
- B. All materials stored onsite will be stored in a neat, orderly manner and, if possible, under a roof or other enclosure.
- C. Products will be kept in their original containers with the original manufacturer's label in legible condition.
- D. Substances will not be mixed with one another unless recommended by the manufacturer.
- E. Whenever possible, all of a product will be used up before disposing of the container.
- F. Manufacturer's recommendations for proper use and disposal will be followed.
- G. The job site superintendent will be responsible for daily inspections to ensure proper use and disposal of materials.

2.2 Hazardous Products

These practices will be used to reduce the risks associated with hazardous materials.

- A. Products will be kept in original containers with the original labels in legible condition.
- B. Original labels and material safety data sheets (MSDS's) will be procured and used for each material.
- C. If surplus product must be disposed of, manufacturers or local/state/federal recommended methods for proper disposal will be followed.
- D. A spill control and containment kit (containing, for example, absorbent such as kitty litter or sawdust, acid neutralizing powder, brooms, dust pans, mops, rags, gloves, goggles, plastic and metal trash containers, etc.) will be provided at the storage site.
- E. All of the product in a container will be used before the container is disposed of. All such containers will be triple rinsed with water prior to disposal. The rinse water used in these containers will be disposed of in a manner in compliance with state and federal regulations and will not be allowed to mix with stormwater discharges.

2.3 Product Specific Practices

The following product specific practices will be followed on the job site.

A. Petroleum Products

All onsite vehicles will be monitored for leaks and receive regular preventative maintenance to reduce the chance of leakage. Petroleum products will be stored in tightly sealed containers which are clearly labeled. Any petroleum storage tanks used onsite will have a dike or berm containment structure constructed around it to contain any spills which may occur. Any asphalt substances used onsite will be applied according to the manufacturer's recommendations.

B. Fertilizers

Fertilizers will be applied only in the minimum amounts recommended by the manufacturer. Once applied, fertilizer will be worked in the soil to limit exposure to stormwater. Storage will be in a covered shed. The contents of any partially used bags of fertilizer will be transferred to a sealable plastic bin to avoid spills.

C. Paints, Paint Solvents, and Cleaning Solvents

All containers will be tightly sealed and stored when not in use. Excess paint and solvents will not be discharged to the storm sewer system but will be properly disposed of according to manufacturer's instructions or state and federal regulations.

D. Concrete Trucks

The CGP authorizes the land disposal of wash out water from concrete trucks at construction sites that are regulated under the CGP, as long as the discharge is in compliance with the restrictions given in Section 3.02.4.B of this SWPPP. This authorization is limited to the land disposal of wash out water from concrete trucks only. Any other direct discharge of concrete production waste water is not authorized by the CGP and must be authorized under a separate TCEQ General Permit or individual permit.

2.4 Spill Prevention Practices

In addition to the good housekeeping and material management practices discussed in the previous sections of this plan, the following practices will be followed for spill prevention and cleanup.

- A. Manufacturer's recommended methods for spill cleanup will be clearly posted and site personnel will be trained regarding these procedures and the location of the information and cleanup supplies.
- B. Materials and equipment necessary for spill cleanup will be kept in the material storage area onsite in spill control and containment kit (containing, for example, absorbent such as kitty litter or sawdust, acid neutralizing powder, brooms, dust pans, mops, rags, gloves, goggles, plastic and metal trash containers, etc.).
- C. All spills will be cleaned up immediately after discovery.
- D. The spill area will be kept well ventilated and personnel will wear appropriate protective clothing to prevent injury from contact with the hazardous substances.
- E. Spills of toxic or hazardous materials will be reported to the appropriate federal, state, and/or local government agency, regardless of the size of the spill. Spills of amounts that exceed Reportable Quantities of certain substances specifically mentioned in federal regulations (40 CFR 302 list and oil) will be immediately reported to the TCEQ National Response Center, telephone **1-800-832-8224**. Reportable Quantities of some substances which may be used at the job site are as follows:
 - oil - appearance of a film or sheen on water
 - pesticides - usually 1 lb.
 - acids - 5000 lb.
 - solvents, flammable - 100 lb.
- F. The SPCC plan will be adjusted to include measures to prevent this type of spill from recurring and how to clean up the spill if there is another one. A description of the spill, what caused it, and the

cleanup measures will also be included. If the spill exceeds a Reportable Quantity, all federal regulations regarding reports of the incident will be complied with.

- G. The job site superintendent will be the spill prevention and cleanup coordinator. He will designate the individuals who will receive spill prevention and cleanup training. These individuals will each become responsible for a particular phase of prevention and cleanup. The names of these personnel will be posted in the material storage area and in the office trailer onsite.

Spills: Reportable Quantities

The RQ depends on the substance released and where released. Use this table to determine whether you must report and under what rule.

In Texas, upon determining that a reportable discharge or spill has occurred, the responsible person must notify the state. The threshold quantity that triggers the requirement to report a spill is called the **reportable quantity (RQ)**. The reportable quantity depends on the type of substance released and where released (e.g. into water vs. on land); different kinds of spills are subject to different provisions of state and federal rules.

Kind of spill	Where discharged	Reportable quantity	Rule, statute, or responsible agency
Hazardous substance	onto land	"Final RQ" in Table 302.4 in 40 CFR 302.4 (PDF)	30 TAC 327 ↗
	into water	"Final RQ" or 100 lbs, whichever is less	
Any oil	coastal waters	as required by the Texas General Land Office	Texas General Land Office ↗
Crude oil, oil that is neither a petroleum product nor used oil	onto land	210 gallons (five barrels)	30 TAC 327 ↗
	directly into water	enough to create a sheen	
Petroleum product, used oil	onto land, from an exempt PST facility	210 gallons (five barrels)	30 TAC 327 ↗
	onto land, or onto land from a non-	25 gallons	

exempt PST facility

	directly into water	enough to create a sheen	
Associated with the exploration, development and production of oil, gas, or geothermal resources	under the jurisdiction of the Railroad Commission of Texas	as required by the Railroad Commission of Texas	Railroad Commission of Texas ↗
Industrial solid waste or other substances	into water	100 lbs	30 TAC 327 ↗
From petroleum storage tanks, underground or aboveground	into water	enough to create a sheen on water	30 TAC 334 ↗ .75-81
From petroleum storage tanks, underground or aboveground	onto land	25 gallons or equal to the RQ under 40 CFR 302 ↗	30 TAC 327 ↗
Other substances that may be useful or valuable and are not ordinarily considered to be waste, but will cause pollution if discharged into water in the state	into water	100 lbs	30 TAC 327 ↗

(PDF Help)**Emergency Response Home****Spills, Discharges, and Releases****Hurricanes****Drought****Tornados****Wildfires****Floods**

Winter Storms



How are we doing? Take our customer satisfaction survey

Temporary Stormwater Management Practices TCEQ Form 0602

Attachment B Potential Sources of Contamination

The following are the potential pollutants and their sources which may occur at this construction site: offsite vehicle tracking of mud from vehicle traffic through inadequate construction exit, petroleum based products from vehicle/ equipment leaks and drips (maintenance and petroleum storage areas will not be allowed on the construction site), pesticides and fertilizers from landscaping activities, and high pH washwater from concrete and masonry cleanup/ washout facilities.

Temporary Stormwater Management Practices TCEQ Form 0602

Attachment C Sequence of Major Activities

The Contractor will be responsible for implementing the following erosion and sediment control and stormwater management control structures. The Contractor may designate these tasks to certain subcontractors as he sees fit, but the ultimate responsibility for implementing these controls and ensuring their proper functioning remains with the general contractor. The order of activities will be as follows (refer to Plan Sheet C2.00 Erosion Control Plan in the Construction Plans for the project for details):

- A. Install erosion control barriers around perimeter of property and disturbed areas as shown on the SWPPP plan sheet. (Approx. 7.45 acres)
- B. Install inlet protection for all existing grate inlets, curb inlets, and at the end of all exposed storm sewer pipes, if present. (Approx. 0.1 acres)
- C. Construct temporary construction exit. (Approx. 0.03 acres)
- D. Commence grubbing and removal of vegetation in area to receive cut or fill. (Approx. 6.84 acres)
- E. Commence grading operation for building pad preparation. (Approx. 4.3 acres)
- F. Install all underground utilities. (Approx. 2.5 acres)
- G. Finalize pavement subgrade preparation. (Approx. 1.88 acres)
- H. Install all proposed storm sewer pipes and install inlet protection erosion control log at ends of exposed pipes. (Approx. 0.5 acres)
- I. Install inlet protection at all new grate and curb inlets. (Approx. 0.5 acres)
- J. Construct all grate inlets and drainage structures. Inlet protection erosion control logs may be removed temporarily for this construction. (Approx. 0.1 acres)
- K. Remove erosion control barriers around inlets and manholes no more than 48 hours prior to placing stabilized base course. (Approx. 0.1 acres)
- L. Install base material as required for pavement, curb and gutter. (Approx. 1.88 acres)
- M. Install all paving, curb and gutter. (Approx. 1.88 acres)
- N. Complete planting and/or seeding of vegetated areas to accomplish stabilization, in accordance with the landscaping plan. (Approx. 1.21 acres)
- O. Remove temporary construction exit, erosion control logs, inlet protection, and all other temporary sediment controls. (Approx. 0.1 acres)

Temporary Stormwater Management Practices TCEQ Form 0602

Attachment D Temporary Best Management Practices

The following temporary best management practices will be used on the construction site

Stabilization Practices

1. Land clearing activities shall be done only in areas where earthwork will be performed and shall progress as earthwork is needed
2. Frequent watering of excavation and fill areas to minimize wind erosion during construction.
3. Use of stabilization fabric for all slopes having a slope of 1V:3H or greater.
4. Permanent seeding and planting of all unpaved areas.
5. For all disturbed areas where construction activities have temporarily or permanently ceased for more than 14 days, stabilization activities shall commence no later than the 14th day after cessation of construction activities or after final grades have been achieved.

Temporary Stormwater Management Practices TCEQ Form 0602

Attachment F Structural Practices

The following structural best management practices will be used on the construction site

1. Inlet protection using erosion control logs.
2. Perimeter protection using erosion control logs
3. Stabilized construction access point
4. Temporary concrete washout area

Temporary Stormwater Management Practices TCEQ Form 0602

Attachment G Drainage Area Map

Please refer to Plan Sheets C6.00 Existing Drainage Area Map and C6.01 Proposed Drainage Area Map of the Construction Plans for this project.

Temporary Stormwater Management Practices TCEQ Form 0602

Attachment I Inspection/ Maintenance for BMPs

I. Erosion and Sediment Control Maintenance and Inspection Practices

A. The following is a list of erosion and sediment controls to be used on this site during construction practice.

1. Stabilization practices for this site include:
 - A. Land clearing activities shall be done only in areas where earthwork will be performed and shall progress as earthwork is needed
 - B. Frequent watering of excavation and fill areas to minimize wind erosion during construction.
 - C. Use of stabilization fabric for all slopes having a slope of 1V:3H or greater.
 - D. Permanent seeding and planting of all unpaved areas.
 - E. For all disturbed areas where construction activities have temporarily or permanently ceased for more than 14 days, soil stabilization activities shall commence as soon as practicable but no later than the 14th day after cessation of construction activities.
2. Structural practices for this site include:
 - A. Inlet protection using block and gravel-filled bags and fabric filter material
 - B. Perimeter protection using silt fencing and/or straw roll wattles
 - C. Stabilized construction access point
 - D. Temporary concrete washout area

Velocity Dissipation: Contractor shall provide sufficient velocity dissipation devices to prevent soil erosion at discharge points where concentrated flow occurs or is expected to occur.

B. The following inspection and maintenance practices will be used to maintain erosion and sediment controls.

1. All control measures will be inspected weekly.

2. All measures will be maintained in good working order; if repairs are found to be necessary, they will be initiated within 24 hours of report and completed prior to the next anticipated rainfall event. If completion of required repairs cannot be accomplished prior to the next anticipated rainfall event, the reason shall be documented in the SWPPP for the site and completion shall be accomplished as soon as practicable.
3. Built up sediment will be removed from silt fence when it has reached one-third the height of the fence.
4. Silt fences will be inspected for depth of sediment, tears, to see if the fabric is securely attached to the fence posts, and to see that the fence posts are securely in the ground.
5. The sediment basin, if present, will be inspected for depth of sediment, and built up sediment will be removed when it reaches 50 percent of the design capacity. **Contractor shall install a depth gauge in the sediment basin to use in evaluating the depth of accumulated sediment to determine when sediment removal is required.**
6. Temporary and permanent seeding will be inspected for bare spots, washouts, and healthy growth.
7. A maintenance inspection report will be made after each inspection. Copies of the report forms to be completed by the inspector are included in the SWPPP for the site.
8. The job site superintendent will be responsible for selecting and training the individuals who will be responsible for these inspections, maintenance and repair activities, and filling out inspection and maintenance reports.
9. Personnel selected for the inspection and maintenance responsibilities will receive training from the job site superintendent. They will be trained in all the inspection and maintenance practices necessary for keeping the erosion and sediment controls that are used onsite in good working order. They will also be trained in the completion of, initiation of actions required by, and the filing of the inspection forms. Documentation of the qualifications of inspection personnel must be kept in the SWPPP for the site.

II. Inspection and Maintenance Report Forms

Once installation of any required or optional erosion control device or measure has been implemented, weekly inspections of each measure shall be performed by the Contractor's inspection personnel. The Inspection and Maintenance Reports found in the SWPPP for the site (or other forms which the Contractor desires to use that have been approved by the Engineer) shall be used by the inspectors to inventory and report the condition of each

measure to assist in maintaining the erosion and sediment control measures in good working order.

Based on the results of the periodic inspections, necessary control modifications shall be initiated within 24 hours and completed prior to the next anticipated rain event. These inspection reports shall be kept on file as part of the Storm Water Pollution Prevention Plan for at least three years from the date of completion and submission of the Notice of Termination.

These report forms shall become an integral part of the SWPPP for the site and shall be made readily accessible to TCEQ inspection officials, the Civil Engineering Consultant, and the Owner for review upon request during visits to the project site. In addition, copies of the reports shall be provided to any of these persons, upon request, via mail or facsimile transmission.

III. Summary of Erosion and Sediment Control Maintenance/Inspection Procedures

- All control measures will be inspected at least weekly and after each rainfall event.
- All measures will be maintained in good working order; if a repair is necessary, it will be initiated within 24 hours of report and completed prior to the next anticipated rain event.
- Built-up sediment will be removed from silt fences when it has reached one-third the height of the fence.
- Silt fences will be inspected for depth of sediment, tears, to see if the fabric is securely attached to the fence posts, and to see that the fence posts are firmly in the ground.
- Sediment basins, if present, will be inspected for depth of sediment, and built-up sediment will be removed when it reaches 50% of the design capacity or at the end of the job. **Contractor shall install a depth gauge in the sediment basin to use in evaluating the depth of accumulated sediment to determine when sediment removal is required.**
- Diversion dikes, if present, will be inspected and any breaches promptly repaired.
- If sediment escapes the site, accumulations will be removed at a frequency to minimize further negative effects, and whenever feasible, prior to the next forecasted rain event.
- Temporary and permanent seeding and planting will be inspected for bare spots, washouts, and healthy growth.
- A maintenance inspection report will be made after each inspection. Copies of the report forms to be used are included in the SWPPP for the site.

- The site job superintendent will select the individuals who will be responsible for inspections, maintenance and repair activities, and filling out the inspection and maintenance reports.
- Personnel selected for inspection and maintenance responsibilities will receive training from the site job superintendent. They will be trained in all the inspection and maintenance practices necessary for keeping the erosion and sediment controls used onsite in good working order. Records documenting the training and experience qualifications of each and every inspector shall be kept with the Inspection Record Forms in the SWPPP for the site.

IV. Construction/Implementation Checklist

1. Maintain Records of Construction Activities, including:

- Dates when major grading activities occur
- Dates when construction activities temporarily cease on a portion of the site
- Dates when construction activities permanently cease on a portion of the site
- Dates when stabilization measures are initiated on the site
- Dates of rainfall events and post-rainfall inspections

2. Prepare Inspection Reports summarizing:

- Name of inspector
- Qualifications of Inspector
- Control measures/areas inspected
- Observed conditions and areas of non-compliance
- Location of any discharges of sediments or other pollutants from the site
- Recommended remedial actions and action on previously recommended remedial actions
- Statement that the site is or is not in compliance with the Permit/SWPPP
- Changes necessary to the SWPPP for the site

3. Report Releases of Reportable Quantities of Oil or Hazardous Materials (if they occur):

- Notify TCEQ Spill Response Center **(1-800-832-8224)** immediately

- Notify permitting authority in writing within 14 days
- Modify the pollution prevention plan to include:
 - the date of release
 - circumstances leading to the release
 - steps taken to prevent recurrence of the release

4. Modify Pollution Prevention Plan as necessary to:

- Comply with the minimum permit requirements when notified by TCEQ that the plan does not comply
- Address a change in design, construction operation, or maintenance which has an effect on the potential for discharge of pollutants
- Prevent recurrence of reportable quantity releases of a hazardous material or oil

Temporary Stormwater Management Practices TCEQ Form 0602

Attachment J Interim/ permanent soil stabilization practices

Final Stabilization/Termination Checklist

- All soil disturbing activities are complete
- Temporary erosion and sediment control measures have been removed or will be removed at an appropriate time
- All areas of the construction site not otherwise covered by a permanent pavement or structure have been stabilized with a uniform perennial vegetative cover with a density of 70% or equivalent measures have been employed
- Bare soils should be seeded or otherwise stabilized within 14 calendar days after final grading or where construction activity has temporarily ceased for more than 21 days.

Permanent Stormwater Section

Texas Commission on Environmental Quality

for Regulated Activities on the Edwards Aquifer Recharge Zone and Relating to 30 TAC §213.5(b)(4)(C), (D)(li), (E), and (5), Effective June 1, 1999

To ensure that the application is administratively complete, confirm that all fields in the form are complete, verify that all requested information is provided, consistently reference the same site and contact person in all forms in the application, and ensure forms are signed by the appropriate party.

Note: Including all the information requested in the form and attachments contributes to more streamlined technical reviews.

Signature

To the best of my knowledge, the responses to this form accurately reflect all information requested concerning the proposed regulated activities and methods to protect the Edwards Aquifer. This **Permanent Stormwater Section** is hereby submitted for TCEQ review and executive director approval. The application was prepared by:

Print Name of Customer/Agent: Robert Adams, PE

Date: 3.8.24

Signature of Customer/Agent



Regulated Entity Name: Jade at Chisholm Trail

Permanent Best Management Practices (BMPs)

Permanent best management practices and measures that will be used during and after construction is completed.

- Permanent BMPs and measures must be implemented to control the discharge of pollution from regulated activities after the completion of construction.
 N/A
- These practices and measures have been designed, and will be constructed, operated, and maintained to insure that 80% of the incremental increase in the annual mass loading of total suspended solids (TSS) from the site caused by the regulated activity is removed. These quantities have been calculated in accordance with technical guidance prepared or accepted by the executive director.
 The TCEQ Technical Guidance Manual (TGM) was used to design permanent BMPs and measures for this site.

A technical guidance other than the TCEQ TGM was used to design permanent BMPs and measures for this site. The complete citation for the technical guidance that was used is: _____

N/A

3. Owners must insure that permanent BMPs and measures are constructed and function as designed. A Texas Licensed Professional Engineer must certify in writing that the permanent BMPs or measures were constructed as designed. The certification letter must be submitted to the appropriate regional office within 30 days of site completion.

N/A

4. Where a site is used for low density single-family residential development and has 20 % or less impervious cover, other permanent BMPs are not required. This exemption from permanent BMPs must be recorded in the county deed records, with a notice that if the percent impervious cover increases above 20% or land use changes, the exemption for the whole site as described in the property boundaries required by 30 TAC §213.4(g) (relating to Application Processing and Approval), may no longer apply and the property owner must notify the appropriate regional office of these changes.

The site will be used for low density single-family residential development and has 20% or less impervious cover.

The site will be used for low density single-family residential development but has more than 20% impervious cover.

The site will not be used for low density single-family residential development.

5. The executive director may waive the requirement for other permanent BMPs for multi-family residential developments, schools, or small business sites where 20% or less impervious cover is used at the site. This exemption from permanent BMPs must be recorded in the county deed records, with a notice that if the percent impervious cover increases above 20% or land use changes, the exemption for the whole site as described in the property boundaries required by 30 TAC §213.4(g) (relating to Application Processing and Approval), may no longer apply and the property owner must notify the appropriate regional office of these changes.

Attachment A - 20% or Less Impervious Cover Waiver. The site will be used for multi-family residential developments, schools, or small business sites and has 20% or less impervious cover. A request to waive the requirements for other permanent BMPs and measures is attached.

The site will be used for multi-family residential developments, schools, or small business sites but has more than 20% impervious cover.

The site will not be used for multi-family residential developments, schools, or small business sites.

6. **Attachment B - BMPs for Upgradient Stormwater.**

- A description of the BMPs and measures that will be used to prevent pollution of surface water, groundwater, or stormwater that originates upgradient from the site and flows across the site is attached.
 - No surface water, groundwater or stormwater originates upgradient from the site and flows across the site, and an explanation is attached.
 - Permanent BMPs or measures are not required to prevent pollution of surface water, groundwater, or stormwater that originates upgradient from the site and flows across the site, and an explanation is attached.
7. **Attachment C - BMPs for On-site Stormwater.**
- A description of the BMPs and measures that will be used to prevent pollution of surface water or groundwater that originates on-site or flows off the site, including pollution caused by contaminated stormwater runoff from the site is attached.
 - Permanent BMPs or measures are not required to prevent pollution of surface water or groundwater that originates on-site or flows off the site, including pollution caused by contaminated stormwater runoff, and an explanation is attached.
8. **Attachment D - BMPs for Surface Streams.** A description of the BMPs and measures that prevent pollutants from entering surface streams, sensitive features, or the aquifer is attached. Each feature identified in the Geologic Assessment as sensitive has been addressed.
- N/A
9. The applicant understands that to the extent practicable, BMPs and measures must maintain flow to naturally occurring sensitive features identified in either the geologic assessment, executive director review, or during excavation, blasting, or construction.
- The permanent sealing of or diversion of flow from a naturally-occurring sensitive feature that accepts recharge to the Edwards Aquifer as a permanent pollution abatement measure has not been proposed.
 - Attachment E - Request to Seal Features.** A request to seal a naturally-occurring sensitive feature, that includes, for each feature, a justification as to why no reasonable and practicable alternative exists, is attached.
10. **Attachment F - Construction Plans.** All construction plans and design calculations for the proposed permanent BMP(s) and measures have been prepared by or under the direct supervision of a Texas Licensed Professional Engineer, and are signed, sealed, and dated. The plans are attached and, if applicable include:
- Design calculations (TSS removal calculations)
 - TCEQ construction notes
 - All geologic features
 - All proposed structural BMP(s) plans and specifications
- N/A

11. **Attachment G - Inspection, Maintenance, Repair and Retrofit Plan.** A plan for the inspection, maintenance, repairs, and, if necessary, retrofit of the permanent BMPs and measures is attached. The plan includes all of the following:
- Prepared and certified by the engineer designing the permanent BMPs and measures
 - Signed by the owner or responsible party
 - Procedures for documenting inspections, maintenance, repairs, and, if necessary retrofit
 - A discussion of record keeping procedures
- N/A
12. **Attachment H - Pilot-Scale Field Testing Plan.** Pilot studies for BMPs that are not recognized by the Executive Director require prior approval from the TCEQ. A plan for pilot-scale field testing is attached.
- N/A
13. **Attachment I -Measures for Minimizing Surface Stream Contamination.** A description of the measures that will be used to avoid or minimize surface stream contamination and changes in the way in which water enters a stream as a result of the construction and development is attached. The measures address increased stream flashing, the creation of stronger flows and in-stream velocities, and other in-stream effects caused by the regulated activity, which increase erosion that results in water quality degradation.
- N/A

Responsibility for Maintenance of Permanent BMP(s)

Responsibility for maintenance of best management practices and measures after construction is complete.

14. The applicant is responsible for maintaining the permanent BMPs after construction until such time as the maintenance obligation is either assumed in writing by another entity having ownership or control of the property (such as without limitation, an owner's association, a new property owner or lessee, a district, or municipality) or the ownership of the property is transferred to the entity. Such entity shall then be responsible for maintenance until another entity assumes such obligations in writing or ownership is transferred.
- N/A
15. A copy of the transfer of responsibility must be filed with the executive director at the appropriate regional office within 30 days of the transfer if the site is for use as a multiple single-family residential development, a multi-family residential development, or a non-residential development such as commercial, industrial, institutional, schools, and other sites where regulated activities occur.
- N/A

Permanent Stormwater Management Practices TCEQ Form 0600

Attachment B BMPs for upgradient stormwater

No offsite stormwater runoff upgradient of the site and flows across the site. The site to the north has swales which capture the on-site/upgradient flow and directs it to the east and west of our site.

Permanent Stormwater Management Practices TCEQ Form 0600

Attachment C BMPs for onsite stormwater

Construction Phase

Please refer to Plan Sheets C2.00 (Erosion Control Plan), C6.03, C6.04, C6.05, C6.06 (Drainage Plans), and C8.00, C8.01 (Erosion Control Details) of the construction plans and the Storm Water Pollution Prevention Plan prepared for this construction site for more information and details about the information presented below.

Stabilization practices for this site include:

1. Land clearing activities shall be done only in areas where earthwork will be performed and shall progress as earthwork is needed
2. Frequent watering of excavation and fill areas to minimize wind erosion during construction.
3. Permanent seeding and planting of all unpaved areas.
4. Use of stabilization fabric for all slopes having a slope of 1V:3H or greater
5. For all disturbed areas where construction activities have temporarily or permanently ceased for more than 14 days, stabilization activities shall commence no later than the 14th day after cessation of construction activities.

Structural practices for this site include:

1. Inlet protection using block and gravel filled bags and silt fence
2. Perimeter protection using silt fencing and/or erosion control logs
3. Stabilized construction access point
4. The on-site underground detention pond will be utilized as a temporary sediment pond during construction activities at the site. Discharge from this pond will be to an existing storm main in Chisholm Trail Road and ultimately Onion Branch.
5. Contractor shall provide sufficient velocity dissipation devices in the form of rock check dams and/or rock rip rap for velocity dissipation at areas with existing or potential channelized flow.

Permanent phase: water quality BMP/ detention vault

An on-site storm runoff will be treated by use of two Jellyfish Filters which have been sized in accordance with the TCEQ Edwards Aquifer Compliance Technical Guidance Manual on Best Management Practices. All storm water runoff (both surface runoff and runoff from roof drains into a subsurface stormwater collection system, from the site will be routed to one of the two filters by an underground drainage system. After passing through the filters flow will be diverted to the underground detention vault and then to the existing storm main in Chisholm Trail Road.

Permanent Stormwater Management Practices TCEQ Form 0600

Attachment F Construction Plans

Please refer to the construction plans which show the locations and details of the Jellyfish Filters. In addition, the underground detention vault designed by the structural engineer has been included for reference.

Permanent Stormwater Management Practices TCEQ Form 0600

Attachment G Inspection, Maintenance, and Repair

The Owner of the Jellyfish Filters is responsible for the hiring a certified maintenance provider for the inspection, maintenance, repair, and record keeping procedures for the filters to serve this site. A copy of the Contech Jellyfish Filter Maintenance Guide is included in this application and has been provided to the Owner.

Record Keeping: The Owner’s representative shall prepare a signed, written record of each inspection performed and actions performed as a result of the inspection observations, shall maintain those records in the Owner’s office for a period of 5 years, and shall, upon request, make those records available to TCEQ personnel and other agencies with jurisdiction over the site.

Certifications:

G. Robert Adams
Design Engineer

G. Rob Adams
Printed Name

3.8.24
Date



PE Seal

Owner

Venkat Avasarala
Printed Name

Date

Jellyfish[®] Filter Maintenance Guide

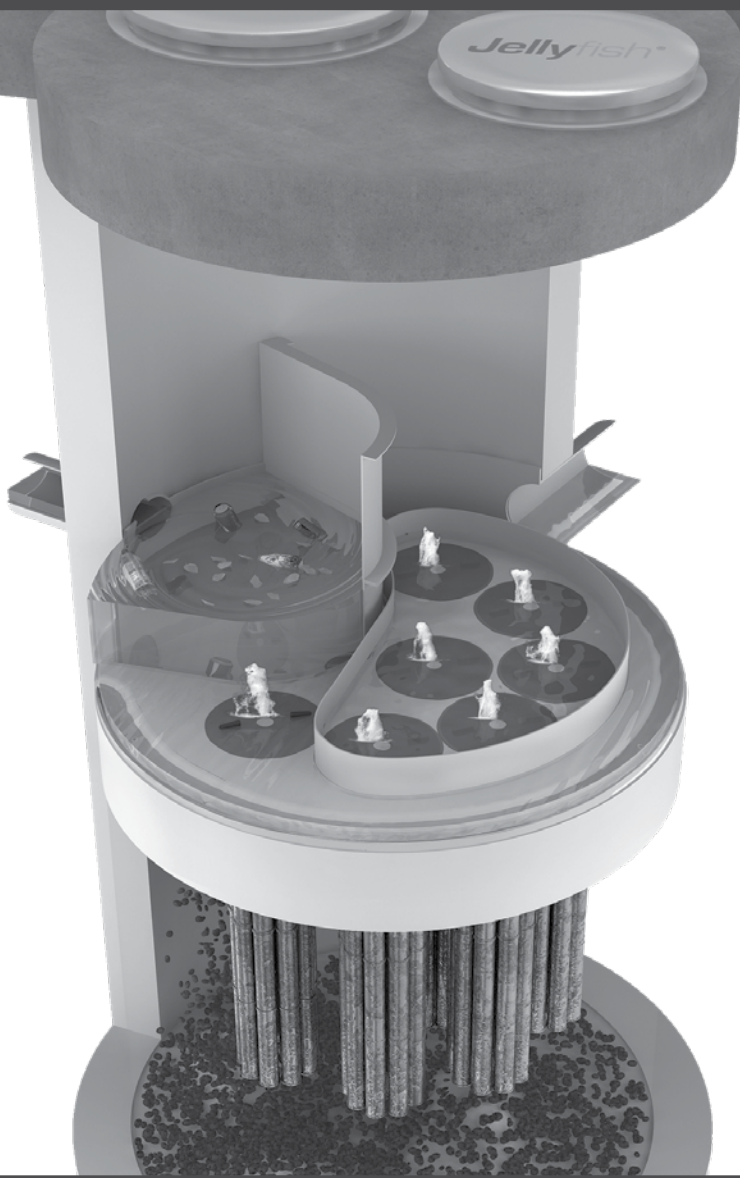



JELLYFISH® FILTER INSPECTION & MAINTENANCE GUIDE

Jellyfish units are often just one of many structures in a more comprehensive stormwater drainage and treatment system.

In order for maintenance of the Jellyfish filter to be successful, it is imperative that all other components be properly maintained. The maintenance and repair of upstream facilities should be carried out prior to Jellyfish maintenance activities.

In addition to considering upstream facilities, it is also important to correct any problems identified in the drainage area. Drainage area concerns may include: erosion problems, heavy oil loading, and discharges of inappropriate materials.

TABLE OF CONTENTS

Inspection and Maintenance Overview	3
Inspection Procedure.....	3
Maintenance Procedure.....	4
Cartridge Assembly & Cleaning.....	5
Inspection Process	7

1.0 Inspection and Maintenance Overview

The primary purpose of the Jellyfish® Filter is to capture and remove pollutants from stormwater runoff. As with any filtration system, these pollutants must be removed to maintain the filter's maximum treatment performance. Regular inspection and maintenance are required to insure proper functioning of the system.

Maintenance frequencies and requirements are site specific and vary depending on pollutant loading. Additional maintenance activities may be required in the event of non-storm event runoff, such as base-flow or seasonal flow, an upstream chemical spill or due to excessive sediment loading from site erosion or extreme runoff events. It is a good practice to inspect the system after major storm events.

Inspection activities are typically conducted from surface observations and include:

- Observe if standing water is present
- Observe if there is any physical damage to the deck or cartridge lids
- Observe the amount of debris in the Maintenance Access Wall (MAW) or inlet bay for vault systems

Maintenance activities include:

- Removal of oil, floatable trash and debris
- Removal of collected sediments
- Rinsing and re-installing the filter cartridges
- Replace filter cartridge tentacles, as needed

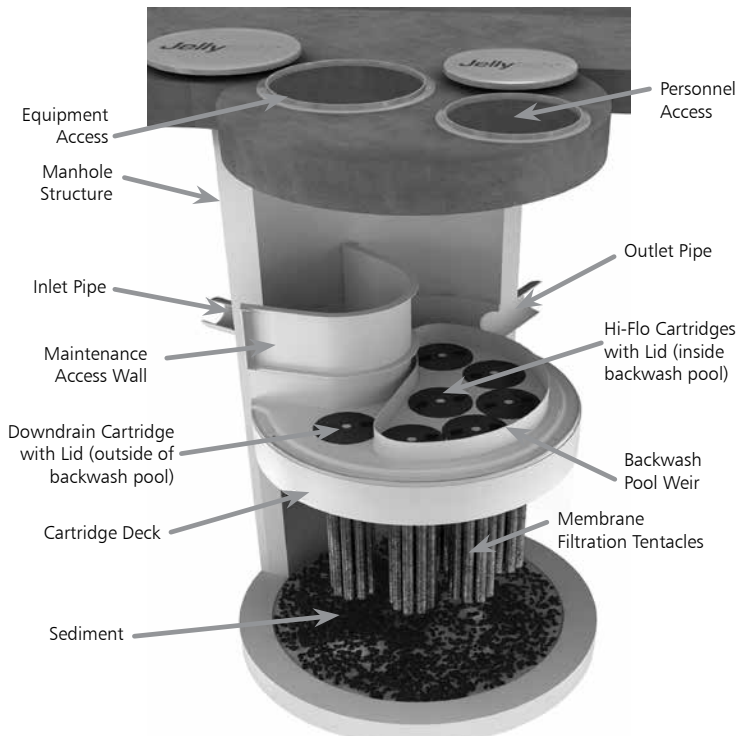

Note: Separator Skirt not shown

2.0 Inspection Timing

Inspection of the Jellyfish Filter is key in determining the maintenance requirements for, and to develop a history of, the site's pollutant loading characteristics. In general, inspections should be performed at the times indicated below; *or per the approved project stormwater quality documents (if applicable), whichever is more frequent.*

1. A minimum of quarterly inspections during the first year of operation to assess the sediment and floatable pollutant accumulation, and to ensure proper functioning of the system.
2. Inspection frequency in subsequent years is based on the inspection and maintenance plan developed in the first year of operation. Minimum frequency should be once per year.
3. Inspection is recommended after each major storm event.
4. Inspection is required immediately after an upstream oil, fuel or other chemical spill.

3.0 Inspection Procedure

The following procedure is recommended when performing inspections:

1. Provide traffic control measures as necessary.
2. Inspect the MAW or inlet bay for floatable pollutants such as trash, debris, and oil sheen.
3. Measure oil and sediment depth in several locations, by lowering a sediment probe until contact is made with the floor of the structure. Record sediment depth, and presences of any oil layers.
4. Inspect cartridge lids. Missing or damaged cartridge lids to be replaced.
5. Inspect the MAW (where appropriate), cartridge deck and receptacles, and backwash pool weir, for damaged or broken components.

3.1 Dry weather inspections

- Inspect the cartridge deck for standing water, and/or sediment on the deck.
- No standing water under normal operating conditions.
- Standing water inside the backwash pool, but not outside the backwash pool indicates, that the filter cartridges need to be rinsed.

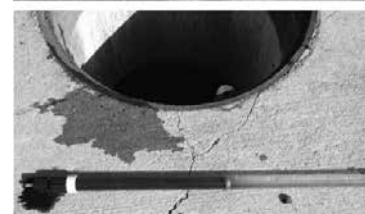

Inspection Utilizing Sediment Probe

- Standing water outside the backwash pool is not anticipated and may indicate a backwater condition caused by high water elevation in the receiving water body, or possibly a blockage in downstream infrastructure.
- Any appreciable sediment ($\geq 1/16''$) accumulated on the deck surface should be removed.

3.2 Wet weather inspections

- Observe the rate and movement of water in the unit. Note the depth of water above deck elevation within the MAW or inlet bay.
- Less than 6 inches, flow should be exiting the cartridge lids of each of the draindown cartridges (i.e. cartridges located outside the backwash pool).
- Greater than 6 inches, flow should be exiting the cartridge lids of each of the draindown cartridges and each of the hi-flo cartridges (i.e. cartridges located inside the backwash pool), and water should be overflowing the backwash pool weir.
- 18 inches or greater and relatively little flow is exiting the cartridge lids and outlet pipe, this condition indicates that the filter cartridges need to be rinsed.

4.0 Maintenance Requirements

Required maintenance for the Jellyfish Filter is based upon results of the most recent inspection, historical maintenance records, or the site specific water quality management plan; whichever is more frequent. In general, maintenance requires some combination of the following:

1. Sediment removal for depths reaching 12 inches or greater, or within 3 years of the most recent sediment cleaning, whichever occurs sooner.
2. Floatable trash, debris, and oil removal.
3. Deck cleaned and free from sediment.
4. Filter cartridges rinsed and re-installed as required by the most recent inspection results, or within 12 months of the most recent filter rinsing, whichever occurs sooner.
5. Replace tentacles if rinsing does not restore adequate hydraulic capacity, remove accumulated sediment, or if damaged or missing. It is recommended that tentacles should remain in service no longer than 5 years before replacement.
6. Damaged or missing cartridge deck components must be repaired or replaced as indicated by results of the most recent inspection.
7. The unit must be cleaned out and filter cartridges inspected immediately after an upstream oil, fuel, or chemical spill. Filter cartridge tentacles should be replaced if damaged or compromised by the spill.

5.0 Maintenance Procedure

The following procedures are recommended when maintaining the Jellyfish Filter:

1. Provide traffic control measures as necessary.
2. Open all covers and hatches. Use ventilation equipment as required, according to confined space entry procedures.
Caution: Dropping objects onto the cartridge deck may cause damage.

3. Perform Inspection Procedure prior to maintenance activity.
4. To access the cartridge deck for filter cartridge service, descend into the structure and step directly onto the deck. Caution: Do not step onto the maintenance access wall (MAW) or backwash pool weir, as damage may result. Note that the cartridge deck may be slippery.
5. Maximum weight of maintenance crew and equipment on the cartridge deck not to exceed 450 lbs.

5.1 Filter Cartridge Removal

1. Remove a cartridge lid.
2. Remove cartridges from the deck using the lifting loops in the cartridge head plate. Rope or a lifting device (available from Contech) should be used. **Caution: Should a snag occur, do not force the cartridge upward as damage to the tentacles may result. Wet cartridges typically weigh between 100 and 125 lbs.**
3. Replace and secure the cartridge lid on the exposed empty receptacle as a safety precaution. Contech does not recommend exposing more than one empty cartridge receptacle at a time.

5.2 Filter Cartridge Rinsing

1. Remove all 11 tentacles from the cartridge head plate. Take care not to lose or damage the O-ring seal as well as the plastic threaded nut and connector.



Cartridge Removal & Lifting Device



2. Position tentacles in a container (or over the MAW), with the threaded connector (open end) facing down, so rinse water is flushed through the membrane and captured in the container.
3. Using the Jellyfish rinse tool (available from Contech) or a low-pressure garden hose sprayer, direct water spray onto the tentacle membrane, sweeping from top to bottom along the length of the tentacle. Rinse until all sediment is removed from the membrane. **Caution: Do not use a high pressure sprayer or focused stream of water on the membrane. Excessive water pressure may damage the membrane.**

4. Collected rinse water is typically removed by vacuum hose.
5. Reassemble cartridges as detailed later in this document. Reuse O-rings and nuts, ensuring proper placement on each tentacle.

5.3 Sediment and Floatables Extraction

1. Perform vacuum cleaning of the Jellyfish Filter only after filter cartridges have been removed from the system. Access the lower chamber for vacuum cleaning only through the maintenance access wall (MAW) opening. Be careful not to damage the flexible plastic separator skirt that is attached to the underside of the deck on manhole systems. Do not lower the vacuum wand through a cartridge receptacle, as damage to the receptacle will result.
2. Vacuum floatable trash, debris, and oil, from the MAW opening or inlet bay. Alternatively, floatable solids may be removed by a net or skimmer.



Vacuuming Sump Through MAW

3. Pressure wash cartridge deck and receptacles to remove all sediment and debris. Sediment should be rinsed into the sump area. Take care not to flush rinse water into the outlet pipe.
4. Remove water from the sump area. Vacuum or pump equipment should only be introduced through the MAW or inlet bay.
5. Remove the sediment from the bottom of the unit through the MAW or inlet bay opening.



Vacuuming Sump Through MAW

6. For larger diameter Jellyfish Filter manholes (≥ 8 -ft) and some vaults complete sediment removal may be facilitated by removing a cartridge lid from an empty receptacle and inserting a jetting wand (not a vacuum wand) through the receptacle. Use the sprayer to rinse loosened sediment toward the vacuum hose in the MAW opening, being careful not to damage the receptacle.

5.4 Filter Cartridge Reinstallation and Replacement

1. Cartridges should be installed after the deck has been cleaned. It is important that the receptacle surfaces be free from grit and debris.
2. Remove cartridge lid from deck and carefully lower the filter cartridge into the receptacle until head plate gasket is seated squarely in receptacle. **Caution: Do not force the cartridge downward; damage may occur.**
3. Replace the cartridge lid and check to see that both male threads are properly seated before rotating approximately 1/3 of a full rotation until firmly seated. Use of an approved rim gasket lubricant may facilitate installation. See next page for additional details.
4. If rinsing is ineffective in removing sediment from the tentacles, or if tentacles are damaged, provisions must be made to replace the spent or damaged tentacles with new tentacles. Contact Contech to order replacement tentacles.

5.5 Chemical Spills

Caution: If a chemical spill has been captured, do not attempt maintenance. Immediately contact the local hazard response agency and contact Contech.

5.6 Material Disposal

The accumulated sediment found in stormwater treatment and conveyance systems must be handled and disposed of in accordance with regulatory protocols. It is possible for sediments to contain measurable concentrations of heavy metals and organic chemicals (such as pesticides and petroleum products). Areas with the greatest potential for high pollutant loading include industrial areas and heavily traveled roads. Sediments and water must be disposed of in accordance with all applicable waste disposal regulations. When scheduling maintenance, consideration must be made for the disposal of solid and liquid wastes. This typically requires coordination with a local landfill for solid waste disposal. For liquid waste disposal a number of options are available including a municipal vacuum truck decant facility, local waste water treatment plant or on-site treatment and discharge.

Jellyfish Filter Components & Filter Cartridge Assembly and Installation

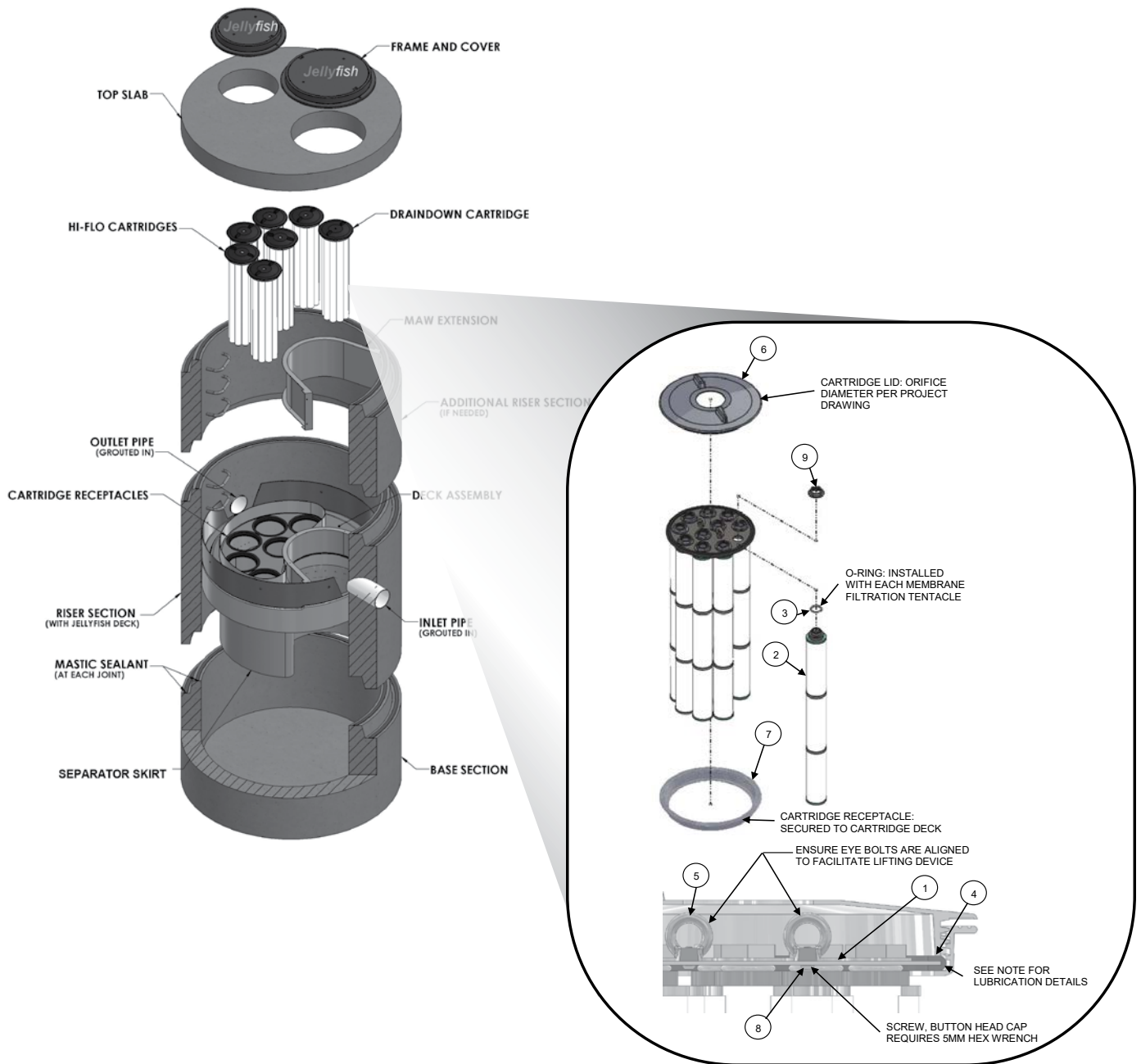

TABLE 1: BOM

ITEM NO.	DESCRIPTION
1	JF HEAD PLATE
2	JF TENTACLE
3	JF O-RING
4	JF HEAD PLATE GASKET
5	JF CARTRIDGE EYELET
6	JF 14IN COVER
7	JF RECEPTACLE
8	BUTTON HEAD CAP SCREW M6X14MM SS
9	JF CARTRIDGE NUT

TABLE 2: APPROVED GASKET LUBRICANTS

PART NO.	MFR	DESCRIPTION
78713	LA-CO	LUBRI-JOINT
40501	HERCULES	DUCK BUTTER
30600	OATEY	PIPE LUBRICANT
PSLUBXL1Q	PROSELECT	PIPE JOINT LUBRICANT

NOTES:

Head Plate Gasket Installation:

Install Head Plate Gasket (Item 4) onto the Head Plate (Item 1) and liberally apply a lubricant from Table 2: Approved Gasket Lubricants onto the gasket where it contacts the Receptacle (Item 7) and Cartridge Lid (Item 6). Follow Lubricant manufacturer's instructions.

Lid Assembly:

Rotate Cartridge Lid counter-clockwise until both male threads drop down and properly seat. Then rotate Cartridge Lid clockwise approximately one-third of a full rotation until Cartridge Lid is firmly secured, creating a watertight seal.

Jellyfish Filter Inspection and Maintenance Log

Owner:		Jellyfish Model No:	
Location:		GPS Coordinates:	
Land Use:	Commercial:	Industrial:	Service Station:
	Roadway/Highway:	Airport:	Residential:

Date/Time:						
Inspector:						
Maintenance Contractor:						
Visible Oil Present: (Y/N)						
Oil Quantity Removed:						
Floatable Debris Present: (Y/N)						
Floatable Debris Removed: (Y/N)						
Water Depth in Backwash Pool						
Draindown Cartridges externally rinsed and recommissioned: (Y/N)						
New tentacles put on Draindown Cartridges: (Y/N)						
Hi-Flo Cartridges externally rinsed and recommissioned: (Y/N)						
New tentacles put on Hi-Flo Cartridges: (Y/N)						
Sediment Depth Measured: (Y/N)						
Sediment Depth (inches or mm):						
Sediment Removed: (Y/N)						
Cartridge Lids intact: (Y/N)						
Observed Damage:						
Comments:						



Support

- Drawings and specifications are available at www.conteches.com/jellyfish.
- Site-specific design support is available from Contech Engineered Solutions.
- Find a Certified Maintenance Provider at www.conteches.com/ccmp

Jellyfish[®]

CONTECH[®]
ENGINEERED SOLUTIONS

800.338.1122

www.ContechES.com

© 2021 Contech Engineered Solutions LLC, a QUIKRETE Company

Contech Engineered Solutions LLC provides site solutions for the civil engineering industry. Contech's portfolio includes bridges, drainage, sanitary sewer, stormwater, wastewater treatment and earth stabilization products. For information on other Contech segment offerings, visit ContechES.com or call 800.338.1122

NOTHING IN THIS CATALOG SHOULD BE CONSTRUED AS A WARRANTY. APPLICATIONS SUGGESTED HEREIN ARE DESCRIBED ONLY TO HELP READERS MAKE THEIR OWN EVALUATIONS AND DECISIONS, AND ARE NEITHER GUARANTEES NOR WARRANTIES OF SUITABILITY FOR ANY APPLICATION. CONTECH MAKES NO WARRANTY WHATSOEVER, EXPRESS OR IMPLIED, RELATED TO THE APPLICATIONS, MATERIALS, COATINGS, OR PRODUCTS DISCUSSED HEREIN. ALL IMPLIED WARRANTIES OF MERCHANTABILITY AND ALL IMPLIED WARRANTIES OF FITNESS FOR ANY PARTICULAR PURPOSE ARE DISCLAIMED BY CONTECH. SEE CONTECH'S CONDITIONS OF SALE (AVAILABLE AT WWW.CONTECHES.COM/COS) FOR MORE INFORMATION.

Permanent Stormwater Management Practices TCEQ Form 0600

Attachment I Measures for minimizing surface stream contamination

An Owner's representative shall visually inspect all roof drains and drive/ parking area inlets in the onsite collection system at a minimum interval of every 3 months. Specific items to be observed are: the amount of sediment and/or trash buildup at inlets (removal required if > 10% of the inlet opening is blocked), the presence of standing water or soggy conditions, indicative of poor drainage, and damage to structural components (pipes, inlet grates).

The stormwater runoff from this site will flow through Jellyfish Filters then an underground detention vault before passing into an existing storm sewer main in Chisholm Trail Road. These combined practices will provide effective measures to minimize surface stream contamination.

Organized Sewage Collection System Application

Texas Commission on Environmental Quality

For Regulated Activities on the Edwards Aquifer Recharge Zone and Relating to 30 TAC §213.5(c), Effective June 1, 1999

To ensure that the application is administratively complete, confirm that all fields in the form are complete, verify that all requested information is provided, consistently reference the same site and contact person in all forms in the application, and ensure forms are signed by the appropriate party.

Note: Including all the information requested in the form and attachments contributes to more streamlined technical reviews.

Regulated Entity Name: Jade at Chisholm Trail

1. **Attachment A – SCS Engineering Design Report.** This Engineering Design Report is provided to fulfill the requirements of 30 TAC Chapter 217, including 217.10 of Subchapter A, §§217.51 – 217.70 of Subchapter C, and Subchapter D as applicable, and is required to be submitted with this SCS Application Form.

Customer Information

2. The entity and contact person responsible for providing the required engineering certification of testing for this sewage collection system upon completion (including private service connections) and every five years thereafter to the appropriate TCEQ region office pursuant to 30 TAC §213.5(c) is:

Contact Person: Venkat Avasarala

Entity: 2200 IH 35 RoundRock, LLC.

Mailing Address: 6521 Hickory Hill Dr

City, State: Plano, Texas

Zip: 75074

Telephone: 281-727-9238

Fax: _____

Email Address: Venkat@strykerprop.com

The appropriate regional office must be informed of any changes in this information within 30 days of the change.

3. The engineer responsible for the design of this sewage collection system is:

Contact Person: G. Robert Adams

Texas Licensed Professional Engineer's Number: 86184

Entity: Langan Engineering

Mailing Address: 2999 Olympus Boulevard, Suite 165

City, State: Dallas, Texas

Zip: 75019

Telephone: 817-328-3212

Fax: _____

Email Address: Radams@langan.com

Project Information

4. Anticipated type of development to be served (estimated future population to be served, plus adequate allowance for institutional and commercial flows):

- Residential: Number of single-family lots: _____
 Multi-family: Number of residential units: 392
 Commercial
 Industrial
 Off-site system (not associated with any development)
 Other: _____

5. The character and volume of wastewater is shown below:

100% Domestic 54,880 gallons/day
 _____% Industrial _____ gallons/day
 _____% Commingled _____ gallons/day
 Total gallons/day: 54,880

6. Existing and anticipated infiltration/inflow is _____ gallons/day. This will be addressed by: Hydraulic effect should be minimal compared to the average daily sewage flow. Abatement measures will consist of strict adherence to pipe construction techniques, bedding, clay cap sanitary sewer trenches, water tight manholes and lids, etc.

7. A Water Pollution Abatement Plan (WPAP) is required for construction of any associated commercial, industrial or residential project located on the Recharge Zone.

- The WPAP application for this development was approved by letter dated _____. A copy of the approval letter is attached.
 The WPAP application for this development was submitted to the TCEQ on with this submission, but has not been approved.
 A WPAP application is required for an associated project, but it has not been submitted.
 There is no associated project requiring a WPAP application.

8. Pipe description:

Table 1 - Pipe Description

<i>Pipe Diameter(Inches)</i>	<i>Linear Feet (1)</i>	<i>Pipe Material (2)</i>	<i>Specifications (3)</i>
8"	717'	PVC	SDR-26

Total Linear Feet: 717'

(1) Linear feet - Include stub-outs and double service connections. Do not include private service laterals.

(2) Pipe Material - If PVC, state SDR value.

(3) Specifications - ASTM / ANSI / AWWA specification and class numbers should be included.

9. The sewage collection system will convey the wastewater to the Brushy Creek East Regional Wastewater (name) Treatment Plant. The treatment facility is:

- Existing
 Proposed

10. All components of this sewage collection system will comply with:

- The City of Round Rock standard specifications.
 Other. Specifications are attached.

11. No force main(s) and/or lift station(s) are associated with this sewage collection system.
 A force main(s) and/or lift station(s) is associated with this sewage collection system and the **Lift Station/Force Main System Application** form (TCEQ-0624) is included with this application.

Alignment

12. There are no deviations from uniform grade in this sewage collection system without manholes and with open cut construction.

13. There are no deviations from straight alignment in this sewage collection system without manholes.

Attachment B - Justification and Calculations for Deviation in Straight Alignment without Manholes. A justification for deviations from straight alignment in this sewage collection system without manholes with documentation from pipe manufacturer allowing pipe curvature is attached.

For curved sewer lines, all curved sewer line notes (TCEQ-0596) are included on the construction plans for the wastewater collection system.

Manholes and Cleanouts

14. Manholes or clean-outs exist at the end of each sewer line(s). These locations are listed below: (Please attach additional sheet if necessary)

Table 2 - Manholes and Cleanouts

<i>Line</i>	<i>Shown on Sheet</i>	<i>Station</i>	<i>Manhole or Clean-out?</i>
SSWR 1	C7.00 Of	1+82.21	MH
SSWR 1	C7.00 Of	4+66.96	MH
SSWR 1	C7.00 Of	7+17.16	MH
	Of		
	Of		
	Of		

<i>Line</i>	<i>Shown on Sheet</i>	<i>Station</i>	<i>Manhole or Clean-out?</i>
	Of		
	Of		
	Of		
	Of		

15. Manholes are installed at all Points of Curvature and Points of Termination of a sewer line.
16. The maximum spacing between manholes on this project for each pipe diameter is no greater than:

Pipe Diameter (inches)	Max. Manhole Spacing (feet)
6 - 15	500
16 - 30	800
36 - 48	1000
≥54	2000

- Attachment C – Justification for Variance from Maximum Manhole Spacing.** The maximum spacing between manholes on this project (for each pipe diameter used) is greater than listed in the table above. A justification for any variance from the maximum spacing is attached, and must include a letter from the entity which will operate and maintain the system stating that it has the capability to maintain lines with manhole spacing greater than the allowed spacing.
17. All manholes will be monolithic, cast-in-place concrete.
- The use of pre-cast manholes is requested for this project. The manufacturer's specifications and construction drawings, showing the method of sealing the joints, are attached.

Site Plan Requirements

Items 18 - 25 must be included on the Site Plan.

18. The Site Plan must have a minimum scale of 1" = 400'.
Site Plan Scale: 1" = 40'.
19. The Site Plan must include the sewage collection system general layout, including manholes with station numbers, and sewer pipe stub outs (if any). Site plan must be overlain by topographic contour lines, using a contour interval of not greater than ten feet and showing the area within both the five-year floodplain and the 100-year floodplain of any drainage way.
20. Lateral stub-outs:
- The location of all lateral stub-outs are shown and labeled.

- No lateral stub-outs will be installed during the construction of this sewer collection system.

21. Location of existing and proposed water lines:

- The entire water distribution system for this project is shown and labeled.
- If not shown on the Site Plan, a Utility Plan is provided showing the entire water and sewer systems.
- There will be no water lines associated with this project.

22. 100-year floodplain:

- After construction is complete, no part of this project will be in or cross a 100-year floodplain, either naturally occurring or manmade. (Do not include streets or concrete-lined channels constructed above of sewer lines.)
- After construction is complete, all sections located within the 100-year floodplain will have water-tight manholes. These locations are listed in the table below and are shown and labeled on the Site Plan. (Do not include streets or concrete-lined channels constructed above sewer lines.)

Table 3 - 100-Year Floodplain

<i>Line</i>	<i>Sheet</i>	<i>Station</i>
	of	to
	of	to
	of	to
	of	to

23. 5-year floodplain:

- After construction is complete, no part of this project will be in or cross a 5-year floodplain, either naturally occurring or man-made. (Do not include streets or concrete-lined channels constructed above sewer lines.)
- After construction is complete, all sections located within the 5-year floodplain will be encased in concrete or capped with concrete. These locations are listed in the table below and are shown and labeled on the Site Plan. (Do not include streets or concrete-lined channels constructed above sewer lines.)

Table 4 - 5-Year Floodplain

<i>Line</i>	<i>Sheet</i>	<i>Station</i>
	of	to
	of	to
	of	to
	of	to

- 24. Legal boundaries of the site are shown.

25. The **final plans and technical specifications** are submitted for the TCEQ's review. Each sheet of the construction plans and specifications are dated, signed, and sealed by the Texas Licensed Professional Engineer responsible for the design on each sheet.

Items 26 - 33 must be included on the Plan and Profile sheets.

26. All existing or proposed water line crossings and any parallel water lines within 9 feet of sewer lines are listed in the table below. These lines must have the type of pressure rated pipe to be installed shown on the plan and profile sheets. Any request for a variance from the required pressure rated piping at crossings must include a variance approval from 30 TAC Chapter 290.

There will be no water line crossings.

There will be no water lines within 9 feet of proposed sewer lines.

Table 5 - Water Line Crossings

<i>Line</i>	<i>Station or Closest Point</i>	<i>Crossing or Parallel</i>	<i>Horizontal Separation Distance</i>	<i>Vertical Separation Distance</i>
SSWR 2	0+20.88	Crossing		2.57-ft
SSWR 3	0+17.87	Crossing		2.73-ft
SSWR 1	7+35.16	Crossing		2.02-ft

27. Vented Manholes:

No part of this sewer line is within the 100-year floodplain and vented manholes are not required by 30 TAC Chapter 217.

A portion of this sewer line is within the 100-year floodplain and vented manholes will be provided at less than 1500 foot intervals. These water-tight manholes are listed in the table below and labeled on the appropriate profile sheets.

A portion of this sewer line is within the 100-year floodplain and an alternative means of venting shall be provided at less than 1500 feet intervals. A description of the alternative means is described on the following page.

A portion of this sewer line is within the 100-year floodplain; however, there is no interval longer than 1500 feet located within. No vented manholes will be used.

Table 6 - Vented Manholes

<i>Line</i>	<i>Manhole</i>	<i>Station</i>	<i>Sheet</i>

<i>Line</i>	<i>Manhole</i>	<i>Station</i>	<i>Sheet</i>

28. Drop manholes:

- There are no drop manholes associated with this project.
- Sewer lines which enter new or existing manholes or "manhole structures" higher than 24 inches above the manhole invert are listed in the table below and labeled on the appropriate profile sheets. These lines meet the requirements of 30 TAC §217.55(l)(2)(H).

Table 7 - Drop Manholes

<i>Line</i>	<i>Manhole</i>	<i>Station</i>	<i>Sheet</i>

29. Sewer line stub-outs (For proposed extensions):

- The placement and markings of all sewer line stub-outs are shown and labeled.
- No sewer line stub-outs are to be installed during the construction of this sewage collection system.

30. Lateral stub-outs (For proposed private service connections):

- The placement and markings of all lateral stub-outs are shown and labeled.
- No lateral stub-outs are to be installed during the construction of this sewage collection system.

31. Minimum flow velocity (From Appendix A)

- Assuming pipes are flowing full; all slopes are designed to produce flows equal to or greater than 2.0 feet per second for this system/line.

32. Maximum flow velocity/slopes (From Appendix A)

- Assuming pipes are flowing full, all slopes are designed to produce maximum flows of less than or equal to 10 feet per second for this system/line.
- Attachment D – Calculations for Slopes for Flows Greater Than 10.0 Feet per Second.** Assuming pipes are flowing full, some slopes produce flows which are greater than 10 feet per second. These locations are listed in the table below. Calculations are attached.

Table 8 - Flows Greater Than 10 Feet per Second

<i>Line</i>	<i>Profile Sheet</i>	<i>Station to Station</i>	<i>FPS</i>	<i>% Slope</i>	<i>Erosion/Shock Protection</i>

33. Assuming pipes are flowing full, where flows are ≥ 10 feet per second, the provisions noted below have been made to protect against pipe displacement by erosion and/or shock under 30 TAC §217.53(l)(2)(B).

- Concrete encasement shown on appropriate Plan and Profile sheets for the locations listed in the table above.
- Steel-reinforced, anchored concrete baffles/retards placed every 50 feet shown on appropriate Plan and Profile sheets for the locations listed in the table above.
- N/A

Administrative Information

- 34. The final plans and technical specifications are submitted for TCEQ review. Each sheet of the construction plans and specifications are dated, signed, and sealed by the Texas Licensed Professional Engineer responsible for the design on each sheet.
- 35. Standard details are shown on the detail sheets, which are dated, signed, and sealed by the Texas Licensed Professional Engineer, as listed in the table below:

Table 9 - Standard Details

<i>Standard Details</i>	<i>Shown on Sheet</i>
Lateral stub-out marking [Required]	N/A of
Manhole, showing inverts comply with 30 TAC §217.55(l)(2) [Required]	C7.01 of
Alternate method of joining lateral to existing SCS line for potential future connections [Required]	N/A of
Typical trench cross-sections [Required]	C8.04 of
Bolted manholes [Required]	N/A of
Sewer Service lateral standard details [Required]	N/A of
Clean-out at end of line [Required, if used]	N/A of
Baffles or concrete encasement for shock/erosion protection [Required, if flow velocity of any section of pipe >10 fps]	N/A of
Detail showing Wastewater Line/Water Line Crossing [Required, if crossings are proposed]	C7.01 of
Mandrel detail or specifications showing compliance with 30 TAC §217.57(b) and (c) [Required, if Flexible Pipe is used]	N/A of

Standard Details	Shown on Sheet
Drop manholes [Required, if a pipe entering a manhole is more than 24 inches above manhole invert]	N/A of

- 36. All organized sewage collection system general construction notes (TCEQ-0596) are included on the construction plans for this sewage collection system.
- 37. All proposed sewer lines will be sufficiently surveyed/staked to allow an assessment prior to TCEQ executive director approval. If the alignments of the proposed sewer lines are not walkable on that date, the application will be deemed incomplete and returned.
 - Survey staking was completed on this date: 04/06/2022
- 38. Submit one (1) original and one (1) copy of the application, plus additional copies as needed for each affected incorporated city, groundwater conservation district, and county in which the project will be located. The TCEQ will distribute the additional copies to these jurisdictions. The copies must be submitted to the appropriate regional office.
- 39. Any modification of this SCS application will require TCEQ approval, prior to construction, and may require submission of a revised application, with appropriate fees.

Signature

To the best of my knowledge, the responses to this form accurately reflect all information requested concerning the proposed regulated activities and methods to protect the Edwards Aquifer. This **Organized Sewage Collection System Application** is hereby submitted for TCEQ review and executive director approval. The system was designed in accordance with the requirements of 30 TAC §213.5(c) and 30 TAC §217 and prepared by:

Print Name of Licensed Professional Engineer: G. Robert Adams

Date: 3.8.24

Place engineer's seal here:

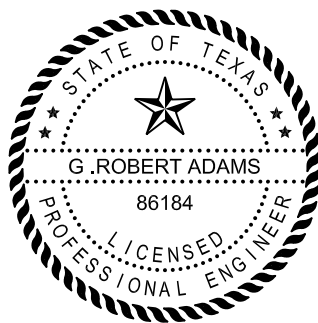

Signature of Licensed Professional Engineer:

G. Robert Adams

Appendix A-Flow Velocity Table

Flow Velocity (Flowing Full) All gravity sewer lines on the Edwards Aquifer Recharge Zone shall be designed and constructed with hydraulic slopes sufficient to give a velocity when flowing full of not less than 2.0 feet per second, and not greater than 10 feet per second. The grades shown in the following table are based on Manning's formula and an n factor of 0.013 and shall be the minimum and maximum acceptable slopes unless provisions are made otherwise.

Table 10 - Slope Velocity

Pipe Diameter(Inches)	% Slope required for minimum flow velocity of 2.0 fps	% Slope which produces flow velocity of 10.0 fps
6	0.50	12.35
8	0.33	8.40
10	0.25	6.23
12	0.20	4.88
15	0.15	3.62
18	0.11	2.83
21	0.09	2.30
24	0.08	1.93
27	0.06	1.65
30	0.055	1.43
33	0.05	1.26
36	0.045	1.12
39	0.04	1.01
>39	*	*

*For lines larger than 39 inches in diameter, the slope may be determined by Manning's formula (as shown below) to maintain a minimum velocity greater than 2.0 feet per second when flowing full and a maximum velocity less than 10 feet per second when flowing full.

$$v = \frac{1.49}{n} \times R_h^{0.67} \times \sqrt{S}$$

Figure 1 - Manning's Formula

Where:

v = velocity (ft/sec)

n = Manning's roughness coefficient (0.013)

Rh = hydraulic radius (ft)

S = slope (ft/ft)

ENGINEERING DESIGN REPORT

for

JADE AT CHISHOLM TRAIL Round Rock, Texas

Prepared For:

**Texas Commission on Environmental Quality
Edwards Aquifer Protection Program Austin Regional Office
P.O. Box 13087
Austin, TX 78711-3087**

Prepared By:

**Langan Engineering and Environmental Services, Inc.
9606 N. Mopac Expressway, Suite 110
Austin, TX 78759**

**G. Robert Adams, PE
Professional Engineer License No. 86184**

**March 06, 2024
Langan Project Number: 531017601**

LANGAN

INTRODUCTION

This design report is prepared in accordance with accepted engineering practices and the requirements of the Texas Commission on Environmental Quality (30 TAC 217). The specific design parameters for daily wastewater influent loading used in this report utilize the Round Rock Code of Ordinance – Section 4-82 Water and Wastewater Impact Fees to calculate the Service Unit Equivalent (LUEs) for the 392-unit building. This approach has also been approved by the City of Round Rock through a wastewater capacity analysis.

The purpose of this report is to provide engineering design data for the sanitary sewer collection system serving the Jade at Chisholm Trail multi-family development. The tract is 6.84 acres and located on the east side of Chisholm Trail Road (between Old Settlers Road and Chisholm Parkway) in the city of Round Rock, Williamson County, Texas. The site will include a four-story building, internal parking structure, courtyards, and on-site amenities for residents.

Sanitary sewer from the site will be collected and flow via gravity through 8-inch sewer lines. Three new manholes will be constructed on the site. There are three waterline crossings of the sanitary sewer system. The on-site collection system will connect to an existing 8-inch gravity main that was constructed in 2012 as part of the Chisholm Trail Road Reconstruction project. The existing 8-inch main was designed to handle the wastewater flow from the site where the Jade at Chisholm Trail will be. The existing 8-inch main is part of the City of Round Rock sanitary sewer collection system and sewage will be conveyed to the city's existing Brushy Creek East Regional Wastewater Treatment Plant for treatment.

Description of the Proposed System

The plans and specifications which describe the project are in compliance with all of the requirements of the TCEQ's TAC Chapter 217. The estimated flow in the sanitary sewer main is 54,880 gallons/day and will be transported from the building through 717 linear feet of PVC SDR 26 ASTM D3034.

Some of the sanitary sewer will be under internal roads. Therefore, the live and dead loads on the 8" pipe were evaluated to determine if the pipe deflections will be within acceptable range. HS20 vehicle loading was chosen as the live load considering that semi-tractor trailer trucks may access these internal roads. Based on the depth of the pipes the live load on the pipe ranged from 1.28 to 1.08 psi with total loads ranging from 10.08 to 10.93 psi. Deflections of the pipes were calculated to be between 1.29 to 1.40%.

The sanitary sewer pipes are designed with a slope that will provide a velocity of at least 2 feet per second, as calculated using a Manning's equation with an "n" value of 0.013 for the pipes. Also, at full flow the collection system is designed not to exceed a velocity of 10 feet per second.

No part of the project will be in the 100-year or 5-year floodplain.

Design Flows

The specific design parameters for daily wastewater influent loading used in this report are estimated as follows: utilization of the Round Rock Code of Ordinance – Section 4-82 Water and Wastewater Impact Fees to calculate the Service Unit Equivalentents (LUEs) and the Round Rock Utility Criteria Manual section 1 – Water, Reuse Water, and Wastewater subsection 1.6.3 Wastewater Systems to calculate wastewater flows and inflow and infiltration.

TABLE 1: ESTIMATED WASTEWATER FLOW RATE

Land Use and Acreage	# of Units to be served	Service Unit Equivalentents for daily wastewater	Service Units (LUEs)	Estimated Average daily flow, gal/min
Multi-Family (Residential) 6.84 acres	392 units	0.5 per unit	196	38.1 gpm

$F = \text{Average Daily Flow (gpm)} = 80 \text{ gal/per} * \# \text{ of LUEs} * 3.5/1440$

$\text{Average Dry Weather Flow} = 80 * 196 * 3.5/1440 = 38.1 \text{ gpm}$

$\text{Average Dry Weather Flow} = 38.1 * 1440 = 54,880 \text{ gpd}$

$\text{Peak Dry Weather Flow} = ((18 + (0.018 * F)^{0.5}) / (4 + (0.018 * F)^{0.5})) * F$

$\text{Peak Dry WF} = ((18 + 0.018 * 38.1)^{0.5}) / (4 + (0.018 * 38.1)^{0.5}) * 38.1 = 148.6 \text{ gpm}$

$I/I = 750 \text{ gpd/acre} * 0.18 \text{ acre} = 140 \text{ gpd} = 0.1 \text{ gpm}$

$\text{Peak Wet Weather Flow} = 148.6 \text{ gpm} + 0.1 \text{ gpm} = 148.7 \text{ gpm}$

Pipe Capacity

$148.7 \text{ gpm} / 448.8 = 0.32 \text{ cfs}$

$\text{Full Flow of 8" pipe at 0.40\% (n=0.013)} = 0.77 \text{ cfs}$

$0.32 \text{ cfs} / 0.71 \text{ cfs} = 41.5\% \text{ pipe capacity}$

Line ID	Downstream Station	Upstream Station	Length	Slope	Diameter	n	Q	V
-	-	-	ft	ft/ft	inches	-	cfs	ft/sec
SSWR1	0+00.00	7+17.16	717.16	0.004	8	0.013	0.77	2.20

Structural Design

Input

	Depth	Deflection	Dead Load	Live Load	Total Load	Allowable Deflection 2%
8"	10.56 ft	1.29%	8.8 psi	1.28 psi	10.08 psi	OK
8"	11.82 ft	1.40%	9.85 psi	1.08 psi	10.93 psi	OK

Calculation Inputs

E': 1000.0 lbs/in²

E'b: 1000.0 lbs/in²

Time Lag Factor: 1.0

Pipe Stiffness: 115 psi

Bedding Constant: 0.1

Earth Load Pressure: 120 lb/cuft

Trench Width: 24.0"

Output

Allowable deflection is 2%. Max calculated deflection is 1.17% **OK**

Agent Authorization Form
For Required Signature
Edwards Aquifer Protection Program
Relating to 30 TAC Chapter 213
Effective June 1, 1999

I _____ Venkat Avasarala _____
Print Name

_____ OWNER _____
Title - Owner/President/Other

of _____ 2200 N IH 35 Round Rock, LLC _____
Corporation/Partnership/Entity Name

have authorized _____ Robert Adams, PE _____
Print Name of Agent/Engineer

of _____ Langan Engineering _____
Print Name of Firm

to represent and act on the behalf of the above named Corporation, Partnership, or Entity for the purpose of preparing and submitting this plan application to the Texas Commission on Environmental Quality (TCEQ) for the review and approval consideration of regulated activities.

I also understand that:

1. The applicant is responsible for compliance with 30 Texas Administrative Code Chapter 213 and any condition of the TCEQ's approval letter. The TCEQ is authorized to assess administrative penalties of up to \$10,000 per day per violation.
2. For those submitting an application who are not the property owner, but who have the right to control and possess the property, additional authorization is required from the owner.
3. Application fees are due and payable at the time the application is submitted. The application fee must be sent to the TCEQ cashier or to the appropriate regional office. The application will not be considered until the correct fee is received by the commission.
4. A notarized copy of the Agent Authorization Form must be provided for the person preparing the application, and this form must accompany the completed application.
5. No person shall commence any regulated activity on the Edwards Aquifer Recharge Zone, Contributing Zone or Transition Zone until the appropriate application for the activity has been filed with and approved by the Executive Director.

SIGNATURE PAGE:

Sai Venkatarao
Applicant's Signature

10/31/2023
Date

THE STATE OF Texas §
County of Collin §

BEFORE ME, the undersigned authority, on this day personally appeared Sai Venkatarao ^{Avasarela} known to me to be the person whose name is subscribed to the foregoing instrument, and acknowledged to me that (s)he executed same for the purpose and consideration therein expressed.

GIVEN under my hand and seal of office on this 31st day of October, 2023

[Signature]

NOTARY PUBLIC

Wenxin Cao

Typed or Printed Name of Notary

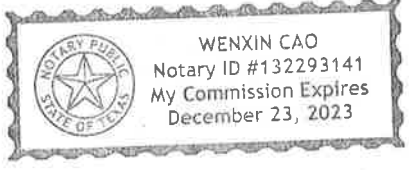

MY COMMISSION EXPIRES: 12/23/2023

Application Fee Form

Texas Commission on Environmental Quality

Name of Proposed Regulated Entity: Jade at Chisholm Trail

Regulated Entity Location: 2250 N IH35, Round Rock, Texas 78681

Name of Customer: 2200 IH 35 RoundRock, LLC.

Contact Person: Venkat Avasarala

Phone: 281-727-9238

Customer Reference Number (if issued): CN _____

Regulated Entity Reference Number (if issued): RN _____

Austin Regional Office (3373)

Hays

Travis

Williamson

San Antonio Regional Office (3362)

Bexar

Medina

Uvalde

Comal

Kinney

Application fees must be paid by check, certified check, or money order, payable to the **Texas Commission on Environmental Quality**. Your canceled check will serve as your receipt. **This form must be submitted with your fee payment.** This payment is being submitted to:

Austin Regional Office

San Antonio Regional Office

Mailed to: TCEQ - Cashier

Overnight Delivery to: TCEQ - Cashier

Revenues Section

12100 Park 35 Circle

Mail Code 214

Building A, 3rd Floor

P.O. Box 13088

Austin, TX 78753

Austin, TX 78711-3088

(512)239-0357

Site Location (Check All That Apply):

Recharge Zone

Contributing Zone

Transition Zone

<i>Type of Plan</i>	<i>Size</i>	<i>Fee Due</i>
Water Pollution Abatement Plan, Contributing Zone Plan: One Single Family Residential Dwelling	Acres	\$
Water Pollution Abatement Plan, Contributing Zone Plan: Multiple Single Family Residential and Parks	6.84 Acres	\$ 5000
Water Pollution Abatement Plan, Contributing Zone Plan: Non-residential	Acres	\$
Sewage Collection System	717 L.F.	\$ 650
Lift Stations without sewer lines	Acres	\$
Underground or Aboveground Storage Tank Facility	Tanks	\$
Piping System(s)(only)	Each	\$
Exception	Each	\$
Extension of Time	Each	\$

Signature: G. Koval

Date: 3.8.24

Application Fee Schedule

Texas Commission on Environmental Quality

Edwards Aquifer Protection Program 30 TAC Chapter 213 (effective 05/01/2008)

Water Pollution Abatement Plans and Modifications

Contributing Zone Plans and Modifications

<i>Project</i>	<i>Project Area in Acres</i>	<i>Fee</i>
One Single Family Residential Dwelling	< 5	\$650
Multiple Single Family Residential and Parks	< 5	\$1,500
	5 < 10	\$3,000
	10 < 40	\$4,000
	40 < 100	\$6,500
	100 < 500	\$8,000
	≥ 500	\$10,000
Non-residential (Commercial, industrial, institutional, multi-family residential, schools, and other sites where regulated activities will occur)	< 1	\$3,000
	1 < 5	\$4,000
	5 < 10	\$5,000
	10 < 40	\$6,500
	40 < 100	\$8,000
	≥ 100	\$10,000

Organized Sewage Collection Systems and Modifications

<i>Project</i>	<i>Cost per Linear Foot</i>	<i>Minimum Fee- Maximum Fee</i>
Sewage Collection Systems	\$0.50	\$650 - \$6,500

Underground and Aboveground Storage Tank System Facility Plans and Modifications

<i>Project</i>	<i>Cost per Tank or Piping System</i>	<i>Minimum Fee- Maximum Fee</i>
Underground and Aboveground Storage Tank Facility	\$650	\$650 - \$6,500

Exception Requests

<i>Project</i>	<i>Fee</i>
Exception Request	\$500

Extension of Time Requests

<i>Project</i>	<i>Fee</i>
Extension of Time Request	\$150



TCEQ Use Only

TCEQ Core Data Form

For detailed instructions regarding completion of this form, please read the Core Data Form Instructions or call 512-239-5175.

SECTION I: General Information

1. Reason for Submission (If other is checked please describe in space provided.)		
<input checked="" type="checkbox"/> New Permit, Registration or Authorization (Core Data Form should be submitted with the program application.)		
<input type="checkbox"/> Renewal (Core Data Form should be submitted with the renewal form)	<input type="checkbox"/> Other	
2. Customer Reference Number (if issued)	Follow this link to search for CN or RN numbers in Central Registry**	3. Regulated Entity Reference Number (if issued)
CN		RN

SECTION II: Customer Information

4. General Customer Information		5. Effective Date for Customer Information Updates (mm/dd/yyyy)	
<input checked="" type="checkbox"/> New Customer		<input type="checkbox"/> Update to Customer Information	
<input type="checkbox"/> Change in Legal Name (Verifiable with the Texas Secretary of State or Texas Comptroller of Public Accounts)		<input type="checkbox"/> Change in Regulated Entity Ownership	
The Customer Name submitted here may be updated automatically based on what is current and active with the Texas Secretary of State (SOS) or Texas Comptroller of Public Accounts (CPA).			
6. Customer Legal Name (If an individual, print last name first: eg: Doe, John)		If new Customer, enter previous Customer below:	
2200 IH 35 RouncRock, LLC			
7. TX SOS/CPA Filing Number	8. TX State Tax ID (11 digits)	9. Federal Tax ID (9 digits)	10. DUNS Number (if applicable)
0804531139	32084208795	208420879	
11. Type of Customer:	<input checked="" type="checkbox"/> Corporation	<input type="checkbox"/> Individual	Partnership: <input type="checkbox"/> General <input type="checkbox"/> Limited
Government: <input type="checkbox"/> City <input type="checkbox"/> County <input type="checkbox"/> Federal <input type="checkbox"/> State <input type="checkbox"/> Other	<input type="checkbox"/> Sole Proprietorship	<input type="checkbox"/> Other:	
12. Number of Employees		13. Independently Owned and Operated?	
<input checked="" type="checkbox"/> 0-20 <input type="checkbox"/> 21-100 <input type="checkbox"/> 101-250 <input type="checkbox"/> 251-500 <input type="checkbox"/> 501 and higher		<input checked="" type="checkbox"/> Yes <input type="checkbox"/> No	
14. Customer Role (Proposed or Actual) – as it relates to the Regulated Entity listed on this form. Please check one of the following			
<input checked="" type="checkbox"/> Owner <input type="checkbox"/> Operator <input type="checkbox"/> Owner & Operator			
<input type="checkbox"/> Occupational Licensee <input type="checkbox"/> Responsible Party <input type="checkbox"/> Voluntary Cleanup Applicant <input type="checkbox"/> Other:			
15. Mailing Address:	6521 Hickory Hill Dr		
	City	Plano	State TX ZIP 75074 ZIP + 4
16. Country Mailing Information (if outside USA)		17. E-Mail Address (if applicable)	
		Venkat@strykerprop.com	
18. Telephone Number	19. Extension or Code	20. Fax Number (if applicable)	
(281) 727-9238		() -	

SECTION III: Regulated Entity Information

21. General Regulated Entity Information (If 'New Regulated Entity' is selected below this form should be accompanied by a permit application)	
<input checked="" type="checkbox"/> New Regulated Entity <input type="checkbox"/> Update to Regulated Entity Name <input type="checkbox"/> Update to Regulated Entity Information	
The Regulated Entity Name submitted may be updated in order to meet TCEQ Agency Data Standards (removal of organizational endings such as Inc, LP, or LLC).	
22. Regulated Entity Name (Enter name of the site where the regulated action is taking place.)	
Jade at Chisholm Trail	

23. Street Address of the Regulated Entity: <i>(No PO Boxes)</i>	2250 N IH 35							
	City	RoundRock	State	TX	ZIP	78681	ZIP + 4	
24. County								

Enter Physical Location Description if no street address is provided.

25. Description to Physical Location:	Approximately 1,800 LF north of intersection of Chisholm Trail Road and Chisholm Parkway between Chisholm Trail Road and the S IH 35 frontage road.								
26. Nearest City	Round Rock				State	Tx		Nearest ZIP Code	78681
27. Latitude (N) In Decimal:	30.532778			28. Longitude (W) In Decimal:	-97.693611				
Degrees	Minutes	Seconds	Degrees	Minutes	Seconds				
30	31	58	-97	41	37				
29. Primary SIC Code (4 digits)	30. Secondary SIC Code (4 digits)		31. Primary NAICS Code (5 or 6 digits)		32. Secondary NAICS Code (5 or 6 digits)				
6513			531110						
33. What is the Primary Business of this entity? <i>(Do not repeat the SIC or NAICS description.)</i>									
Multi-Family Housing									
34. Mailing Address:	6521 Hickory Hill Dr								
	City	Plano	State	TX	ZIP	75074	ZIP + 4		
35. E-Mail Address:	Venkat@strykerprop.com								
36. Telephone Number	37. Extension or Code			38. Fax Number (if applicable)					
(281) 727-9238				() -					

39. TCEQ Programs and ID Numbers Check all Programs and write in the permits/registration numbers that will be affected by the updates submitted on this form. See the Core Data Form instructions for additional guidance.

<input type="checkbox"/> Dam Safety	<input type="checkbox"/> Districts	<input checked="" type="checkbox"/> Edwards Aquifer	<input type="checkbox"/> Emissions Inventory Air	<input type="checkbox"/> Industrial Hazardous Waste
<input type="checkbox"/> Municipal Solid Waste	<input type="checkbox"/> New Source Review Air	<input type="checkbox"/> OSSF	<input type="checkbox"/> Petroleum Storage Tank	<input type="checkbox"/> PWS
<input type="checkbox"/> Sludge	<input type="checkbox"/> Storm Water	<input type="checkbox"/> Title V Air	<input type="checkbox"/> Tires	<input type="checkbox"/> Used Oil
<input type="checkbox"/> Voluntary Cleanup	<input type="checkbox"/> Waste Water	<input type="checkbox"/> Wastewater Agriculture	<input type="checkbox"/> Water Rights	<input type="checkbox"/> Other:

SECTION IV: Preparer Information

40. Name:	G. Rob Adams, PE		41. Title:	Principal/Vice President	
42. Telephone Number	43. Ext./Code	44. Fax Number	45. E-Mail Address		
(817) 328-3212		() -	radams@langan.com		

SECTION V: Authorized Signature

46. By my signature below, I certify, to the best of my knowledge, that the information provided in this form is true and complete, and that I have signature authority to submit this form on behalf of the entity specified in Section II, Field 6 and/or as required for the updates to the ID numbers identified in field 39.

Company:	Langan Engineering		Job Title:	Principal/Vice President	
Name (In Print):	G. Rob Adams, PE			Phone:	(737) 289- 7810
Signature:				Date:	3.8.24

GENERAL NOTES

- 1. EXISTING TOPOGRAPHIC, BOUNDARY AND UTILITY INFORMATION AS SHOWN ON THESE DESIGN DOCUMENT(S) ARE BASED ON PLAN(S) TOPOGRAPHIC SURVEY BEING A PORTION OF DAVID CURRY SURVEY ABSTRACT NO. 130 PREPARED BY WINDROSE LAND SERVICE, LLC., ROUND ROCK, TX, DATED 2022 APRIL 06, LAST REVISED 2023 APRIL 28.
ACTUAL SITE CONDITIONS MAY VARY FROM THOSE ENCOUNTERED AT THE TIME THE SURVEY DATA SHOWN HEREON WAS OBTAINED.
PRIOR TO ANY USE OF THIS DATA, INCLUDING BUT NOT LIMITED TO DESIGN OR CONSTRUCTION, THE APPROPRIATE DATA CONFIRMATIONS SHALL BE MADE.
BASED ON THE REFERENCED INFORMATION, ALL ELEVATIONS AND ESTABLISHED GRADES SHOWN HEREON REFER TO NAVD 89 DATUM.
2. THE CONTRACTOR SHALL BEGIN WORK AS DIRECTED BY THE OWNER/CITY OR THE NOTICE TO PROCEED.
3. THE CONTRACTOR IS RESPONSIBLE FOR OBTAINING ALL NECESSARY PERMITS, APPROVALS, AND INSPECTIONS PRIOR TO AND THROUGHOUT CONSTRUCTION.
4. IT IS THE CONTRACTOR'S RESPONSIBILITY TO MAINTAIN NEAT AND ACCURATE CONSTRUCTION RECORDS FOR THE OWNER/CITY'S USE. THE CONTRACTOR SHALL PROVIDE THE CITY CLEAN AND ACCURATE FULL SIZE REPRODUCIBLE RECORD DRAWINGS WHICH CLEARLY DESCRIBE ALL CONSTRUCTION AND ANY DEVIATIONS FROM THE PLANS.
5. ALL SHOP DRAWINGS AND SUBMITTALS SHALL BE PROOFREAD AND REVIEWED BY THE GENERAL CONTRACTOR FOR APPROVAL PRIOR TO SUBMITTAL TO THE ENGINEER. SUBCONTRACTOR / GENERAL CONTRACTOR SHALL CLEARLY INDICATE, MARK, HIGHLIGHT, AND PROPERLY CLARIFY PRODUCTS TO BE CONSIDERED FOR APPROVAL. SUBMITTALS NOT PROOFREAD OR REVIEWED OR CLARIFIED PROPERLY SHALL BE RETURNED UNREVIEWED. CONTRACTOR SHALL RESUBMIT SHOP DRAWINGS AND ALLOW FOR SUITABLE REVIEW TIME. SUITABLE REVIEW TIME SHALL BE SEVEN (7) WORKING DAYS FOR TYPICAL SUBMITTALS AND LONGER DEPENDING ON THE SIZE AND NATURE OF THE SUBMITTAL.
6. CONTRACTOR SHALL BE RESPONSIBLE FOR QUALITY CONTROL IN THE REQUIRED CONSTRUCTION SURVEYING AND MATERIALS TESTING. DIMENSIONS SHOWN AND DIGITAL FILES PROVIDED SHALL BE USED TO LAYOUT THE SITE.
7. ALL ADJACENT PROPERTY DAMAGED BY THE PROPOSED CONSTRUCTION SHALL BE RESTORED TO EQUAL OR BETTER CONDITION THAN WHICH IT WAS FOUND BEFORE SUCH WORK WAS UNDERTAKEN (NON-PAY ITEM).
8. ALL EFFORTS SHALL BE MADE TO AVOID DAMAGE TO EXISTING TREES THAT ARE TO REMAIN. TREES SHALL BE TRIMMED AND PAINTED ONLY IF NECESSARY FOR THE SAFE MANEUVERING OF CONSTRUCTION EQUIPMENT. CONTRACTOR SHALL RECEIVE PRIOR APPROVAL FROM THE OWNER'S FIELD REPRESENTATIVE FOR REMOVAL OF ANY TREES. WHEN EXCAVATING AROUND A TREE, THE ROOTS SHALL BE CLEAN CUT PRIOR TO ANY EXCAVATION WORK. DO NOT SNAG AND TEAR TREE ROOTS
9. ALL EXISTING FENCES ARE TO REMAIN UNLESS SPECIFIED OTHERWISE BY THE OWNERS REPRESENTATIVE. ANY DAMAGE TO FENCES SHALL BE REPAIRED AT CONTRACTOR'S EXPENSE WITH NEW AND LIKE MATERIALS. TEMPORARY CONSTRUCTION SITE SECURITY FENCES ARE REQUIRED.
10. THE CONTRACTOR IS RESPONSIBLE FOR KEEPING EXISTING DRIVEWAYS AND SIDEWALKS FREE OF MUD AND DEBRIS FROM THE CONSTRUCTION AT ALL TIMES.
11. ALL EXCAVATION IS UNCLASSIFIED AND SHALL INCLUDE ALL MATERIALS ENCOUNTERED TO INCLUDE BUT NOT BE LIMITED TO ROCK, RUBBLE, DEBRIS, TRASH, ETC. UNUSABLE EXCAVATED MATERIAL AND ALL WASTE RESULTING FROM SITE CLEARING AND GRUBBING SHALL BE DISPOSED OF OFF SITE AT THE CONTRACTOR'S EXPENSE UNLESS OTHERWISE SPECIFIED OR AGREED TO BY OWNER.
12. THE CONTRACTOR SHALL TAKE ALL AVAILABLE PRECAUTIONS TO CONTROL DUST. CONTRACTOR SHALL CONTROL DUST BY SPRINKLING WATER, OR BY OTHER MEANS, APPROVED BY THE CITY AND ENGINEER.
13. THE CONTRACTOR SHALL NOTIFY THE OWNER/CITY REPRESENTATIVE OF OFF-SITE EXCESS SPOILS SITES THAT ARE TO BE UTILIZED
14. THE CONTRACTOR SHALL MAINTAIN ADEQUATE SITE DRAINAGE DURING ALL PHASES OF CONSTRUCTION. THE CONTRACTOR SHALL USE SILT FENCES (OR OTHER METHODS APPROVED BY THE ENGINEER AND CITY) AS REQUIRED TO PREVENT SILT AND CONSTRUCTION DEBRIS FROM FLOWING ONTO ADJACENT PROPERTIES. CONTRACTOR SHALL COMPLY WITH ALL APPLICABLE FEDERAL, STATE, OR LOCAL EROSION, CONSERVATION, AND SILTATION ORDINANCES. CONTRACTOR SHALL REMOVE ALL TEMPORARY EROSION CONTROL DEVICES UPON COMPLETION OF PERMANENT DRAINAGE FACILITIES FOR THE ESTABLISHMENT OF GRASS OR OTHER GROWTH TO PREVENT EROSION.
15. DISTURBED AREAS THAT ARE SEEDED SHALL BE CHECKED PERIODICALLY FOR FULL COVERAGE OF GRASS. ALL DISTURBED AREAS SHALL BE WATERED, FERTILIZED, AND SEEDED OR SODDED AS NECESSARY AND BY DEFINITION 'MAINTAINED' UNTIL AN ESTABLISHED STAND OF GRASS CAN BE RELEASED TO THE OWNER. REFERENCE LANDSCAPE/IRRIGATION PLAN (IF PROVIDED) TO COORDINATE PLANTING ENHANCEMENTS AND LIMITS OF IRRIGATION COVERAGE.
16. CONTRACTOR SHALL NOT STORE MATERIALS, EQUIPMENT OR OTHER CONSTRUCTION ITEMS ON ADJACENT PROPERTIES OR ADJACENT RIGHT-OF-WAYS WITHOUT THE PRIOR WRITTEN CONSENT OF THE PROPERTY OWNER AND THE CITY. ALL CONSTRUCTION WASTE MATERIALS TO BE REMOVED SHALL BE DISPOSED OF AT A PERMITTED LOCATION OFF SITE, UNLESS WRITTEN APPROVAL IS OBTAINED FROM THE CITY.
17. THE CONTRACTOR SHALL SET TWO (2) PERMANENT BENCHMARKS IN THE CITY COORDINATE SYSTEM. CONTRACTOR SHALL COORDINATE WITH CITY STAFF FOR RECORDED / APPROVED LOCATIONS.

GENERAL SITE NOTES:

- 1. THE CONTRACTOR SHALL FURNISH, INSTALL, TEST AND COMPLETE ALL WORK TO THE SATISFACTION OF THE ENGINEER AND OWNER IN ACCORDANCE WITH THE CONTRACT DOCUMENTS. THE CONTRACTOR IS SOLELY RESPONSIBLE FOR MEANS AND METHODS OF CONSTRUCTION; AS SUCH, THESE PLANS DO NOT COMPLETELY REPRESENT, NOR ARE THEY INTENDED TO REPRESENT, ALL SPECIFIC INSTRUCTIONS REQUIRED FOR SITEWORK CONSTRUCTION. THE CONTRACTOR IS RESPONSIBLE TO CONSTRUCT ALL IMPROVEMENTS DEPICTED ON THESE PLANS IN ACCORDANCE WITH ALL APPLICABLE RULES, REGULATIONS AND LAWS IN EFFECT AT THE TIME OF CONSTRUCTION.
2. THE CONTRACTOR SHALL ACCEPT THE SITE AS IS. THE CONTRACTOR SHALL ASSESS CONDITIONS, AND THE KIND, QUALITY AND QUANTITY OF WORK REQUIRED. THE OWNER AND ENGINEER MAKE NO GUARANTEE IN REGARD TO THE ACCURACY OF ANY INFORMATION THAT WAS OBTAINED DURING INVESTIGATIONS. THE CONTRACTOR SHALL MAKE A THOROUGH SITE INSPECTION IN ORDER TO FIELD CHECK EXISTING SITE CONDITIONS, CORRELATE CONDITIONS WITH THE DRAWINGS, AND, RESOLVE ANY POSSIBLE CONSTRUCTION CONFLICTS WITH THE OWNER AND ENGINEER PRIOR TO COMMENCEMENT OF WORK. THE CONTRACTOR SHALL PERFORM ADDITIONAL TOPOGRAPHIC SURVEYS HE/SHE DEEMS NECESSARY, PROVIDED THEY ARE COORDINATED WITH THE OWNER, ANY CONDITIONS DETERMINED BY THE CONTRACTOR THAT DIFFER FROM THE INFORMATION SHOWN ON THE DRAWINGS THAT ARE NOT BROUGHT TO THE ATTENTION OF THE OWNER AND ENGINEER PRIOR TO THE START OF WORK SHALL NOT BE CONSIDERED GROUNDS FOR ADDITIONAL PAYMENT OR CHANGES TO THE CONTRACT DURATION, OR ANY OTHER CLAIMS AGAINST THE OWNER OR OWNER'S ENGINEER.
3. THE CONTRACTOR SHALL, WHEN HE/SHE DEEMS NECESSARY, PROVIDE A WRITTEN REQUEST FOR INFORMATION (RFI) TO THE OWNER AND/OR OWNER'S DESIGNATED REPRESENTATIVE, AND ENGINEER PRIOR TO THE CONSTRUCTION OF ANY SPECIFIC SITEWORK ITEM. THE (RFI) SHALL BE IN A FORM ACCEPTABLE TO OWNER AND/OR OWNER'S DESIGNATED REPRESENTATIVE, AND ENGINEER AND SHALL ALLOW FOR A MINIMUM OF THREE WORK DAYS FOR A WRITTEN REPLY. RFIS SHALL BE NUMBERED CONSECUTIVELY BY DATE SUBMITTED. THE CONTRACTOR SHALL BE SOLELY RESPONSIBLE FOR SITEWORK ITEMS CONSTRUCTED DIFFERENTLY THAN INTENDED OR AS DEPICTED ON THE PLANS.
4. INFORMATION RELATED TO ELEVATIONS AND PROPOSED UTILITIES (SUCH AS ROADWAY GRADES, INVERT ELEVATIONS, RIM ELEVATIONS, GRATE ELEVATIONS, BUILDING FINISHED FLOOR ELEVATIONS, ETC.) MAY BE FOUND IN MORE THAN ONE LOCATION IN THE CONTRACT DOCUMENTS. THE CONTRACTOR SHALL SUFFICIENTLY REVIEW ALL PLANS, PROFILES AND ANY OTHER INFORMATION IN THE CONTRACT DOCUMENTS FOR CONSISTENCY PRIOR TO BID, ANY INCONSISTENCIES OR DISCREPANCIES THAT ARE FOUND BY THE CONTRACTOR OR HIS ASSIGNS SHALL BE IMMEDIATELY BROUGHT TO THE ATTENTION OF THE OWNER AND ENGINEER IN WRITING, IN THE FORMAT OF AN RFI PRIOR TO BID.
5. THERE ARE ADDITIONAL NOTES, SPECIFICATIONS AND REQUIREMENTS CONTAINED THROUGHOUT THE PLAN SET AS WELL AS REFERENCES TO SPECIFICATIONS FROM APPLICABLE GOVERNING AUTHORITIES AND INDUSTRY STANDARDS. IT IS THE CONTRACTOR'S RESPONSIBILITY TO OBTAIN, REVIEW AND ADHERE TO ALL THESE DOCUMENTS.
6. CONTRACTOR IS SPECIFICALLY CAUTIONED THAT ALL CONSTRUCTION TAKEOUT FOR THIS PROJECT MUST BE COMPLETED FROM THE SITE SPECIFIC SURVEY CONTROL (HORIZONTAL AND VERTICAL) UPON WHICH THE DESIGN IS BASED. THE CONTRACTOR SHOULD NOT RELY ON OR RE-ESTABLISH SURVEY CONTROL BY GPS OR OTHER METHODS FOR USE IN CONSTRUCTION TAKEOUT OR ANY OTHER PURPOSE FOR THIS PROJECT. ANY DISCREPANCIES BETWEEN THE EXISTING HORIZONTAL OR VERTICAL DATA SHOWN ON THESE DRAWINGS AND THAT ENCOUNTERED IN THE FIELD MUST BE REPORTED TO THE DESIGN TEAM PRIOR TO CONSTRUCTION FOR RESOLUTION.

PAVING NOTES

- 1. THE CONTRACTOR SHALL BE RESPONSIBLE FOR THE COST OF A MAXIMUM NUMBER OF PASSING FIELD DENSITY TESTS ON THE STABILIZED SUBGRADE FOR SITE PAVING EQUAL TO THE RATIO OF 1 PER 5,000 SQUARE FEET OF PAVEMENT (AND ALL FAILING DENSITY TESTS AND REQUIRED MOISTURE DENSITY CURVES). ADDITIONAL FIELD DENSITY TESTS MAY BE REQUIRED FOR FOUNDATIONS. REFER TO STRUCTURAL PLANS AND SPECIFICATIONS FOR SUCH. IN ADDITION, THE CONTRACTOR SHALL PROVIDE THE OWNER TEN (10) PASSING SITE PAVEMENT CORES FOR THE OWNERS USE IN THE OWNER'S TESTING FOR THICKNESS AND COMPRESSIVE STRENGTH. CORE LOCATIONS SHALL BE DESIGNATED BY THE OWNER. CONTRACTOR SHALL PATCH CORE HOLES AND FINISH WITH LIKE AND MATCHING MATERIALS. CONTRACTOR SHALL BE RESPONSIBLE FOR ANY ADDITIONAL TESTING COSTS SHOULD THE ABOVE TESTS FAIL MINIMUM CRITERIA AS ESTABLISHED BY NCTCOG. ANY NON-CONFORMING PAVING SHALL BE REPLACED OR RESOLVED IN ACCORDANCE WITH NCTCOG SPECIFICATIONS.
2. ALL EARTHWORK AND SUBGRADE PREPARATION SHALL BE IN ACCORDANCE WITH THE GEOTECHNICAL INVESTIGATION AS PREPARED BY LANGAN ENGINEERING AND ENVIRONMENTAL SERVICES, INC. AND THOSE RECOMMENDATIONS LISTED WITHIN THE REPORT. REFER TO THIS REPORT FOR ALL EARTHWORK AND RELATED ITEMS. REFER TO STRUCTURAL FOR BUILDING PREP. THE REPORT REFERENCES AGENCY/INDUSTRY STANDARDS. IN THE EVENT THAT THERE IS A QUESTION OR DISPUTE BETWEEN GOVERNING SPECIFICATIONS, THE MOST STRINGENT SHALL APPLY SUCH THAT THE OWNER RECEIVES THE MOST ADVANTAGEOUS FINISHED PRODUCT.
3. THE CONTRACTOR IS SOLELY RESPONSIBLE FOR PERFORMING ALL CONSTRUCTION LAYOUTS FROM THE SITE LAYOUT DIGITAL CONTROL POINTS AND FROM THE DIMENSIONS SHOWN. THE CONTRACTOR MUST NOTIFY THE ENGINEER OF ANY DISCREPANCIES IN ADVANCE AND ALLOW FOR THE ENGINEER'S RESPONSE BEFORE PROCEEDING WITH THE WORK.
4. ALL PAVING DIMENSIONS ARE TO BACK OF CURB, AND EDGE OF PAVEMENT UNLESS OTHERWISE NOTED.
5. IT SHALL BE THE RESPONSIBILITY OF THE CONTRACTOR TO SUPPLY THE CITY AND THE ENGINEER WITH A CONCRETE MIX DESIGN AT THE PRE-CONSTRUCTION MEETING FOR REVIEW AND APPROVAL. THE COST OF THIS DESIGN SHALL BE INCLUDED IN THE UNIT PRICE OF PAVEMENT MATERIAL. FLY ASH IS NOT PERMITTED AS A SUBSTITUTE FOR CEMENT.
6. THE CONTRACTOR SHALL PROTECT ANY EXISTING AND/OR PROPOSED UTILITIES, WHICH ARE IN THE PROPOSED SUBGRADE DURING THE SUBGRADE STABILIZATION PROCESS.
7. CONTRACTOR SHALL ADJUST ALL UTILITIES (EXISTING AND PROPOSED) TO FINAL GRADE (NON-PAY ITEM). ALL UTILITIES AND APPURTENANCES SHALL BE EXTENDED UP TO FINAL GRADE. UTILITY CLEAN-OUTS, VALVES, MANHOLES, ETC. LOCATED WITHIN PAVED AREAS SHALL BE PAVED PER DETAIL. IN NON-PAVED AREAS, SAID APPURTENANCES SHALL HAVE A 4" THICK CONCRETE PAD EXTENDING 12" BEYOND SAID APPURTENANCE (BLOCK OUT) POURED AT FINAL GRADE FOR PROTECTION AGAINST DAMAGE FROM MOWING AND MAINTENANCE EQUIPMENT.
8. PRIOR TO PAVING INSTALLATION, CONTRACTOR TO REFERENCE ALL PLAN SHEETS TO IDENTIFY ALL SLEEVES AND CONDUIT NECESSARY TO SUPPORT FRANCHISE UTILITY SERVICES, TECHNOLOGY/SECURITY, SITE LIGHTING, IRRIGATION, ETC. CONTRACTOR SHALL CONFIRM WITH OWNER AND/OR OWNER'S REPRESENTATIVE TO VERIFY SIZE, LOCATION, AND QUANTITY.
9. UNLESS OTHERWISE NOTED, SUBGRADE SHALL BE STABILIZED TO 12" BEYOND THE BACK OF CURB OR EDGE OF PAVEMENT PER GEOTECH RECOMMENDATIONS UNLESS STATED OTHERWISE. ALL CONCRETE STRENGTH AND REINFORCING STEEL SHALL BE PER PROJECT GEOTECHNICAL RECOMMENDATIONS. FIRE LANES, PARKING STALLS, AND ROADWAY STRIPING & MARKINGS SHALL CONFORM TO CITY STANDARDS. SIDEWALKS WITHIN LANDSCAPE AREAS SHALL BE MINIMUM 4" THICK. LARGE EXPANSES OF CONCRETE FLATWORK (SUCH AS MAJOR PEDESTRIAN AREAS, PLAZA AREAS BETWEEN BUILDINGS OR OTHER STRUCTURES) SHALL BE TREATED LIKE VEHICULAR CONCRETE PAVEMENT AND RECEIVE SAME SUBGRADE STABILIZATION AS VEHICULAR PAVEMENT (6" DEEP MINIMUM AND IN ACCORDANCE WITH SUBGRADE RECOMMENDATION) AND ALL JOINTS (CONTRACTION AND EXPANSION JOINTS) SHALL BE SEALED WITH SELF LEVELING POLYURETHANE SEALANT.
10. ALL PAVEMENT WITHIN 5' OF PROPOSED BUILDING(S) SHALL ADHERE TO THE STRUCTURAL RECOMMENDATIONS AND OR ARCHITECTURAL REQUIREMENTS. REFER TO STRUCTURAL AND ARCHITECTURAL PLANS AND RELATED TECHNICAL SPECIFICATIONS. CIVIL PAVEMENT LIMITS BEGIN 5' OUTSIDE THE BUILDING. IN THE EVENT OF A CONFLICT WITH THE STRUCTURAL AND OR ARCHITECTURAL WITHIN THIS AREA, THE STRUCTURAL/ ARCHITECT REQUIREMENTS SHALL GOVERN.
11. FOR 'CURB INLETS' SUBTRACT 0.5' (6 INCHES) FOR STANDARD THROAT RECESS AT INLETS PER STANDARD DETAILS. SURROUNDING PAVEMENT AND GUTTER SHALL BE WARPPED TO DRAIN FOR INLETS ON GRADE AND SAG INLETS. INLETS ON GRADE SHALL BE SET IN PLACE TO MATCH THE CURB GRADE LINE.
12. ALL REINFORCING STEEL AND DOWEL BARS IN PAVEMENT SHALL BE SUPPORTED AND MAINTAINED AT THE CORRECT CLEARANCES BY THE USE OF BAR CHAIRS OR OTHER APPROVED SUPPORT.
13. CONNECTION OF THE PROPOSED SIDEWALK TO EXISTING PAVING, SIDEWALK, BUILDING, AND WHEELCHAIR RAMPS SHALL BE CONSIDERED SUBSIDIARY TO THE COST OF THE CONSTRUCTION OF THE SIDEWALK. ALL JOINTS (EXPANSION, ISOLATION, CONTRACTION, & CONSTRUCTION) FOR CONCRETE PAVING AND INCIDENTAL CRACKS SHALL BE SEALED AND INSTALLED IN ACCORDANCE WITH THE AMERICAN CONCRETE PAVEMENT ASSOCIATION (ACPA) RECOMMENDATIONS. CONTRACTOR SHALL OBSERVE THE ARCHITECTURAL AND STRUCTURAL JOINTING LAYOUTS. IN THE EVENT OF A DISCREPANCY OR CONFLICT FOR SITE PAVING, THE CONTRACTOR SHALL REFER TO ACPA PUBLICATION IS061.01P AND IS400.01P FOR THE JOINT SPECIFICATIONS AND THE LAYOUT OF PAVEMENT JOINTS (NON-PAY ITEM).
14. JOINT SPACING SHALL BE AS FOLLOWS:
5 INCH PAVEMENT THICKNESS - 10' JOINT SPACING
6+ INCH PAVEMENT THICKNESS - 15' JOINT SPACING OR PER PROJECT GEOTECHNICAL RECOMMENDATIONS
IN AREAS WHERE PAVEMENT THICKNESS VARIES, THE SHORTER JOINT SPACING SHALL GOVERN
15. THE CONTRACTOR SHALL USE CARE DURING SOIL STABILIZATION AND COMPACTION ACTIVITIES SO AS NOT TO ADVERSELY AFFECT LANDSCAPE AREAS OR UTILITY LINES WITH SOIL STABILIZATION TREATMENTS. AFTER COMPACTION AND PRIOR TO PLACING GRASS, THE UPPER 6 INCHES (6") OF ALL LANDSCAPED AREAS SHALL BE AERATED, TILLED, OR OTHERWISE PROCESSED SO AS TO PROMOTE HEALTHY ROOT GROWTH FOR TURF AND OTHER VEGETATION. THE CONTRACTOR WILL BE RESPONSIBLE FOR ANY REPAIRS, UNDERCUTTING, REMOVAL, DISPOSAL, AND BACKFILLING OF THESE AREAS IF STABILIZATION IS DISCOVERED (NON-PAY ITEM).

UTILITY NOTES

- 1. THE CONTRACTOR SHALL BE RESPONSIBLE FOR LOCATING ALL UTILITIES, WHETHER PRIVATE OR PUBLIC, PRIOR TO MOBILIZATION. CONTRACTOR SHALL VISIT THE SITE AND MAKE ALL NECESSARY OBSERVATIONS AND INSPECTIONS TO FAMILIARIZE THEMSELF WITH THE SITE AND THE SITE FACILITIES. THE INFORMATION AND DATA SHOWN WITH RESPECT TO EXISTING UNDERGROUND FACILITIES AT OR CONTIGUOUS TO THE SITE IS APPROXIMATE AND BASED ON INFORMATION FURNISHED BY THE OWNERS OF SUCH UNDERGROUND FACILITIES OR ON PHYSICAL APPURTENANCES OBSERVED IN THE FIELD. THE OWNER AND ENGINEER SHALL NOT BE RESPONSIBLE FOR THE ACCURACY OR COMPLETENESS OF ANY SUCH INFORMATION OR DATA, AND, THE CONTRACTOR, SHALL HAVE FULL RESPONSIBILITY FOR REVIEWING AND CHECKING ALL SUCH INFORMATION AND DATA, FOR LOCATING ALL UNDERGROUND FACILITIES, FOR COORDINATION OF THE WORK WITH THE OWNERS OF SUCH UNDERGROUND FACILITIES DURING CONSTRUCTION, FOR THE SAFETY AND PROTECTION THEREOF, AND REPAIRING ANY DAMAGE THERETO RESULTING FROM THE WORK. THE COST OF ALL WILL BE CONSIDERED AS HAVING BEEN INCLUDED IN THE CONTRACT PRICE.
2. CONTRACTOR SHALL, IN BASE BID PROVIDE ALL NECESSARY FITTINGS AND APPURTENANCES REQUIRED TO COMPLETE ALL CONNECTIONS, RESOLVE UTILITY CONFLICTS AND OTHER INCIDENTAL UTILITY WORK SHOWN ON THE PLANS OR CONTAINED IN THE SPECIFICATIONS OR REQUIRED BY GOVERNING AGENCIES TO INCLUDE, BUT NOT LIMITED TO TEMPORARY SERVICES: VALVES, BOXES, METERS, BACKFLOW PREVENTERS, FIRE DEPARTMENT CONNECTIONS, ETC. INCLUDING THE REPAIR OR REPLACEMENT OF ANY EXISTING IRRIGATION SYSTEM. CONTRACTOR SHALL RAISE/LOWER OR ADJUST ALL EXISTING UTILITY MAINS IN CONFLICT WITH PROPOSED UTILITIES AS PART OF THE BASE BID FOR ALL KNOWN OR UNKNOWN LINES.
3. THE CONTRACTOR SHALL NOTIFY ALL AFFECTED UTILITY COMPANIES OR AGENCIES IN WRITING AT LEAST 1 WEEK PRIOR TO BEGINNING CONSTRUCTION. THE CONTRACTOR SHALL BE RESPONSIBLE FOR AND MAKE ARRANGEMENTS FOR ANY AND ALL TEMPORARY UTILITIES, PERMITS, AND AGREEMENTS.
4. THE CONTRACTOR SHALL PROTECT ALL UTILITIES DURING THE CONSTRUCTION OF THIS PROJECT. THE CONTRACTOR SHALL GIVE THE CITY, RESIDENTS AND BUSINESSES AFFECTED BY ANY ANTICIPATED WATER OR SEWER SERVICE DISRUPTIONS AT LEAST FORTY-EIGHT (48) HOURS PRIOR NOTICE.
5. CONTRACTOR SHALL EXERCISE CAUTION AND MAINTAIN ADEQUATE CLEAR ZONE BETWEEN THE CONTRACTOR'S EQUIPMENT AND ANY POWER LINES.
6. THE CONTRACTOR SHALL PROTECT ALL EXISTING POWER POLES, SIGNS, MANHOLES, TELEPHONES RISERS, WATER VALVES, UTILITIES, ETC. DURING ALL CONSTRUCTION PHASES. CONTRACTOR WILL BE RESPONSIBLE TO REPLACE ANY DAMAGED ITEMS AND RESTORE ANY SERVICES THAT HAVE BEEN DISTURBED. ALL MANHOLES, CLEAN-OUTS, WATER VALVES, FIRE HYDRANTS AND OTHER APPURTENANCES MUST BE ADJUSTED TO FINAL GRADE BEFORE THE OWNER WILL ACCEPT THE WORK.
7. THE CONTRACTOR SHALL SALVAGE ALL EXISTING CITY UTILITIES (INCLUDING SIGNS, VALVES, FIRE HYDRANTS, ETC.) IN ACCORDANCE WITH CITY REQUIREMENTS AND PROVIDE TO THE CITY.
8. ALL UTILITIES WITHIN 5' OF PROPOSED BUILDING(S) SHALL ADHERE TO THE MEP'S RECOMMENDATIONS AND OR REQUIREMENTS. CONTRACTOR SHALL PROVIDE STORM DRAIN CONNECTIONS FOR ALL ROOF DRAIN LINES. REFER TO MEP'S PLANS AND RELATED TECHNICAL SPECIFICATIONS. CIVIL UTILITIES (WATER, SANITARY SEWER & STORM SEWER) LIMITS BEGIN 5' OUTSIDE THE BUILDING. IN THE EVENT OF A CONFLICT WITH THE MEP'S WITHIN THIS AREA, THE MEP'S REQUIREMENTS SHALL GOVERN.
9. TESTING OF UTILITY TRENCH BACKFILL COMPACTION SHALL BE AT 75' INTERVALS AND EACH LIFT'S BACKFILL. BACKFILL SHALL BE PROCESSED SUCH THAT NO DIRT CLOUDS ARE IN EXCESS OF 4" DIAMETER. ALL SANITARY SEWER LINES AND STORM SEWER LINES SHALL BE TV TESTED AT THE COMPLETION OF THE PROJECT (IN ADDITION TO MINIMUM CODE OR OTHER REQUIREMENTS) TO CHECK FOR DAMAGE CAUSED BY OTHER TRADES, UTILITY CONFLICTS, TRENCH SETTLEMENT, ETC. THE COST OF SUCH SHALL BE INCLUDED IN THE CONTRACTORS BASE PRICE.

DEMOLITION NOTES

- 1. NO EARTH-DISTURBING ACTIVITIES SHALL COMMENCE UNTIL ALL PERMITS ARE OBTAINED AND PERIMETER EROSION CONTROL MEASURES ARE IN PLACE.
2. ALL DEMOLITION SHALL BE CLOSELY COORDINATED WITH THE OWNER'S REPRESENTATIVE REGARDING ITEMS TO BE SALVAGED, THOSE TO BE REMOVED, ETC. INCLUDING ANY AND ALL TREE PRESERVATION AND TRANSPLANTING ACTIVITIES, AS OUTLINED IN THE PRE-CONSTRUCTION MEETING. REMOVAL, RELOCATION AND/OR DISPOSAL OF ANY PRE-EXISTING ON-SITE TRASH, DEBRIS, OR STOCKPILES SHALL BE INCLUDED IN THE TOTAL COST OF DEMOLITION AND SHALL BE COORDINATED WITH THE OWNER'S REPRESENTATIVE AT ALL TIMES.
3. CONTRACTOR SHALL COMPLY TO THE FULLEST EXTENT WITH ALL REGULATIONS GOVERNING AGENCIES REGARDING THE DEMOLITION, REMOVAL, TRANSPORTATION AND DISPOSAL OF ALL DEMOLITION DEBRIS.
4. INGRESS AND EGRESS POINTS, PROPOSED DISPOSAL SITES, AND HAUL ROUTES MUST BE APPROVED BY CITY OFFICIALS PRIOR TO REMOVAL OF DEMOLITION DEBRIS OFF-SITE.
5. THE CONTRACTOR SHALL BE RESPONSIBLE FOR COORDINATING DISCONNECTION OF ALL UTILITIES SERVING THE EXISTING SITE WITH THE APPROPRIATE UTILITY COMPANY, AND SHALL OBTAIN APPROVAL FROM SAME TO COMMENCE DEMOLITION ACTIVITIES.
6. CONTRACTOR SHALL COMPLY TO THE FULLEST EXTENT WITH THE LATEST OSHA STANDARDS FOR EXCAVATION AND TRENCHING PROCEDURES. CONTRACTOR SHALL USE SUPPORT SYSTEMS, SLOPING, BENCHING, ETC. AS NECESSARY FOR THESE OPERATIONS, AND SHALL COMPLY WITH ALL OSHA PERFORMANCE CRITERIA.
7. THE CONTRACTOR SHALL ASSUME RESPONSIBILITY FOR THE PROTECTION OF ALL PROPERTY CORNER MONUMENTS, BENCHMARKS, CONTROL POINTS, ETC. AND SHALL HAVE, AT HIS EXPENSE, ALL CORNER MONUMENTS REPLACED WHICH ARE DISTURBED BY CONSTRUCTION ACTIVITIES.
8. THE CONTRACTOR SHALL INCUR ALL COSTS FOR MAINTENANCE AND REPAIR OF THE EXISTING FENCES TO REMAIN, IRRIGATION SYSTEMS TO REMAIN, UTILITY LINES, ETC. AS OUTLINED IN THE SPECIFICATIONS.
9. THE CONTRACTOR SHALL LOCATE AND REMOVE ALL UNDERGROUND UTILITY CABLES (ELECTRIC, TELEPHONE, ETC.) UP TO A DEPTH OF 24 INCHES BELOW GRADE AS PART OF THE BASE BID.
10. THE CONTRACTOR SHALL LOCATE AND REMOVE ALL UNDERGROUND UTILITY PIPING, CONDUIT, AND CABLES, REGARDLESS OF DEPTH, IN THE AREA OF THE PROPOSED BUILDING(S) FOUNDATIONS.
11. NOTES SHOWN HEREON REGARDING SPECIFIC ITEMS OF DEMOLITION ARE GENERAL IN NATURE, AND ARE NOT INTENDED TO BE WHOLLY INCLUSIVE. THE CONTRACTOR SHALL DEMOLISH AND REMOVE ALL EXISTING IMPROVEMENTS TO THE SATISFACTION OF THE OWNER, AS NECESSARY FOR THE CONSTRUCTION OF THE PROPOSED IMPROVEMENTS, AND TO THE EXTENT AS NOTED IN THE SPECIFICATIONS.
12. THE CONTRACTOR SHALL BE RESPONSIBLE FOR PLOUGHING, CAPPING, OR OTHERWISE TERMINATING UTILITY SERVICE LINES AT EXISTING METER LOCATIONS, CLEANOUTS, ETC. A MIN. DISTANCE OF 1 FOOT OUTSIDE THE LIMITS OF THE TRACT SHOWN.
13. THE CONTRACTOR SHALL CREATE AMPLE STAGING AND STOCKPILING AREAS FOR THE DELIVERIES OF CONSTRUCTION MATERIALS, CONCRETE DELIVERIES, TOPSOIL, ETC. IN ACCORDANCE WITH THE OWNER'S REPRESENTATIVE AND THE PROJECT SPECIFICATIONS.

EARTHWORK NOTES

- 1. PLACEMENT OF TOPSOIL TO WITHIN 0.10' OF FINISH GRADE. SEE TOPSOIL SPECIFICATION SHOULD IMPORTED MATERIAL BE NECESSARY.
2. AS A RESULT OF THE SITE GEOLOGY AND PROPOSED SITE PLAN, THE CONTRACTOR SHALL ESTABLISH A SOIL MANAGEMENT PLAN/OPERATION THROUGHOUT THE CONSTRUCTION PROCESS. ALL TOPSOIL SHALL BE SALVAGED AND STOCKPILED ON-SITE. STOCKPILED TOPSOIL MAY BECOME STERILE AND NON-FERTILE OVER TIME. THE CONTRACTOR SHALL AMEND AND SUPPLEMENT THE STOCKPILED TOPSOIL AS NECESSARY TO YIELD A FERTILE TOPSOIL SUPPLY. THE CONTRACTOR'S BID SHALL INCLUDE ALL NECESSARY TOPSOIL (IMPORT MAY BE REQUIRED) AS REQUIRED TO BACKFILL AND CROWN ALL LANDSCAPE ISLANDS AND LANDSCAPE AREAS. THE LACK OF AVAILABLE ON-SITE TOPSOIL WILL NOT BE GROUNDS FOR A CHANGE ORDER OR ADDITIONAL PAY.

SEQUENCING / TRAFFIC CONTROL NOTES

- 1. CONTRACTOR SHALL PREPARE, FURNISH, MAINTAIN, AND REMOVE ALL TRAFFIC CONTROL BARRICADES, WARNING SIGNS, LIGHTS, CONSTRUCTION FENCES, ETC. FOR THE WORK THROUGHOUT CONSTRUCTION. ALL BARRICADES, WARNING SIGNS, LIGHTS, DEVICES, ETC., FOR THE GUIDANCE AND PROTECTION OF TRAFFIC AND PEDESTRIANS MUST CONFORM TO THE INSTALLATION SHOWN IN THE TEXAS MANUAL ON UNIFORM TRAFFIC CONTROL DEVICES, LATEST EDITION AS CURRENTLY AMENDED BY THE TEXAS DEPARTMENT OF TRANSPORTATION.
2. CONTRACTOR SHALL PROVIDE ACCESS TO ALL REQUIRED ENTRANCES AND EXITS AT ALL TIMES THROUGHOUT CONSTRUCTION. CONTRACTOR SHALL PROVIDE A TRAFFIC CONTROL AND SEQUENCING PLAN TO THE ALL AUTHORITIES HAVING JURISDICTION AND COORDINATE THE PLAN AND SCHEDULE WITH THE OWNER PRIOR TO THE START OF CONSTRUCTION.

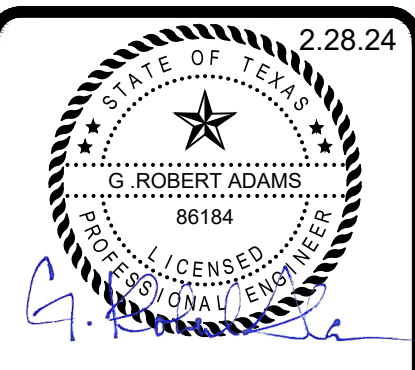
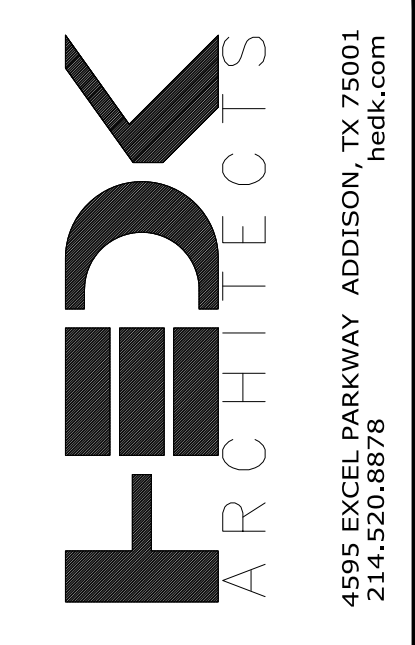

Table with 2 columns: REVISIONS, and a grid for recording revision details.

JADE AT CHISHOLM TRAIL
332 APARTMENT UNITS IN ROUND ROCK, TEXAS
GLENRIDGE DEVELOPMENT

PERMIT SET
ISSUED 02-28-2024



DATE
02-28-2024

PROJECT
22137

SHEET NUMBER
C1.01

GENERAL NOTES

LANGAN
Langan Engineering and Environmental Services, Inc.
9606 N. Mopac Expressway, Suite 110
Austin, TX 78759
T: 737.289.7800 F: 737.289.7801 www.langan.com
TXPE FIRM REG. #F-13709

CITY OF ROUND ROCK NOTES

CITY OF ROUND ROCK GENERAL NOTES:

- ALL CONSTRUCTION SHALL BE IN ACCORDANCE WITH THE CITY OF ROUND ROCK STANDARD SPECIFICATIONS MANUAL.
- ANY EXISTING UTILITIES, PAVEMENT, CURBS, SIDEWALKS, STRUCTURES, TREES, ETC., NOT PLANNED FOR DESTRUCTION OR REMOVAL THAT ARE DAMAGED OR REMOVED SHALL BE REPAIRED OR REPLACED AT HIS EXPENSE.
- THE CONTRACTOR SHALL VERIFY ALL DEPTHS AND LOCATIONS OF EXISTING UTILITIES PRIOR TO ANY CONSTRUCTION. ANY DISCREPANCIES WITH THE CONSTRUCTION PLANS FOUND IN THE FIELD SHALL BE BROUGHT IMMEDIATELY TO THE ATTENTION OF THE ENGINEER WHO SHALL BE RESPONSIBLE FOR REVISING THE PLANS ARE APPROPRIATE.
- MANHOLE FRAMES, COVERS, VALVES, CLEANOUTS, ETC. SHALL BE RAISED TO FINISHED GRADE PRIOR TO FINAL PAVING CONSTRUCTION.
- THE CONTRACTOR SHALL GIVE THE CITY OF ROUND ROCK 48 HOURS NOTICE BEFORE BEGINNING EACH PHASE OF CONSTRUCTION. TELEPHONE 218-5555 (ENGINEERING AND DEVELOPMENT SERVICES DEPARTMENT).
- ALL AREAS DISTURBED OR EXPOSED DURING CONSTRUCTION SHALL BE REVEGETATED IN ACCORDANCE WITH THE PLANS AND SPECIFICATIONS. REVEGETATION OF ALL DISTURBED OR EXPOSED AREAS SHALL CONSIST OF SODDING OR SEEDING, AT THE CONTRACTOR'S OPTION. HOWEVER, THE TYPE OF REVEGETATION MUST EQUAL OR EXCEED THE TYPE OF VEGETATION PRESENT BEFORE CONSTRUCTION.
- PRIOR TO ANY CONSTRUCTION, THE ENGINEER SHALL CONVENE A PRECONSTRUCTION CONFERENCE BETWEEN THE CITY OF ROUND ROCK, HIMSELF, THE CONTRACTOR, OTHER UTILITY COMPANIES, ANY AFFECTED PARTIES AND ANY OTHER ENTITY THE CITY OR ENGINEER MAY REQUIRE.
- THE CONTRACTOR AND THE ENGINEER SHALL KEEP ACCURATE RECORDS OF ALL CONSTRUCTION THAT DEVIATES FROM THE PLANS. THE ENGINEER SHALL FURNISH THE CITY OF ROUND ROCK ACCURATE "AS-BUILT" DRAWINGS FOLLOWING COMPLETION OF ALL CONSTRUCTION. THESE "AS-BUILT" DRAWINGS SHALL MEET WITH THE SATISFACTION OF THE ENGINEERING AND DEVELOPMENT SERVICES DEPARTMENT PRIOR TO FINAL ACCEPTANCE.
- THE ROUND ROCK CITY COUNCIL SHALL NOT BE PETITIONED FOR ACCEPTANCE UNTIL ALL NECESSARY EASEMENT DOCUMENTS HAVE BEEN SIGNED AND RECORDED.
- WHEN CONSTRUCTION IS BEING CARRIED OUT WITHIN EASEMENTS, THE CONTRACTOR SHALL CONFINE HIS WORK TO WITHIN THE PERMANENT AND ANY TEMPORARY EASEMENTS. PRIOR TO FINAL ACCEPTANCE, THE CONTRACTOR SHALL BE RESPONSIBLE FOR REMOVING ALL TRASH AND DEBRIS WITHIN THE PERMANENT AND TEMPORARY EASEMENTS. CLEAN-UP SHALL BE TO THE SATISFACTION OF THE CITY ENGINEER.
- PRIOR TO ANY CONSTRUCTION, THE CONTRACTOR SHALL APPLY FOR AND SECURE ALL PROPER PERMITS FROM THE APPROPRIATE AUTHORITIES.
- AVAILABLE BENCHMARKS (CITY OF ROUND ROCK DATUM) THAT MAY BE UTILIZED FOR THE CONSTRUCTION OF THIS PROJECT ARE DESCRIBED AS FOLLOWS:

CITY OF ROUND ROCK TRENCH SAFETY NOTES:

- IN ACCORDANCE WITH THE LAWS OF THE STATE OF TEXAS AND THE U. S. OCCUPATIONAL SAFETY AND HEALTH ADMINISTRATION REGULATIONS, ALL TRENCHES OVER 5 FEET IN DEPTH IN EITHER HARD AND COMPACT OR SOFT AND UNSTABLE SOIL SHALL BE SLOPED, SHORED, SHEETED, BRACED OR OTHERWISE SUPPORTED. FURTHERMORE, ALL TRENCHES LESS THAN 5 FEET IN DEPTH SHALL ALSO BE EFFECTIVELY PROTECTED WHEN HAZARDOUS GROUND MOVEMENT MAY BE EXPECTED. TRENCH SAFETY SYSTEMS TO BE UTILIZED FOR THIS PROJECT WILL BE PROVIDED BY THE CONTRACTOR.
- IN ACCORDANCE WITH THE U. S. OCCUPATIONAL SAFETY AND HEALTH ADMINISTRATION REGULATIONS, WHEN PERSONS ARE IN TRENCHES 4-FEET DEEP OR MORE, ADEQUATE MEANS OF EXIT, SUCH AS A LADDER OR STEPS, MUST BE PROVIDED AND LOCATED SO AS TO REQUIRE NO MORE THAN 25 FEET OF LATERAL TRAVEL.
- IF TRENCH SAFETY SYSTEM DETAILS WERE NOT PROVIDED IN THE PLANS BECAUSE TRENCHES WERE ANTICIPATED TO BE LESS THAN 5 FEET IN DEPTH AND DURING CONSTRUCTION IT IS FOUND THAT TRENCHES ARE IN FACT 5 FEET OR MORE IN DEPTH OR TRENCHES LESS THAN 5 FEET IN DEPTH ARE IN AN AREA WHERE HAZARDOUS GROUND MOVEMENT IS EXPECTED, ALL CONSTRUCTION SHALL CEASE, THE TRENCHED AREA SHALL BE BARRICADED AND THE ENGINEER NOTIFIED IMMEDIATELY. CONSTRUCTION SHALL NOT RESUME UNTIL APPROPRIATE TRENCH SAFETY SYSTEM DETAILS, AS DESIGNED BY A PROFESSIONAL ENGINEER, ARE RETAINED AND COPIES SUBMITTED TO THE CITY OF ROUND ROCK.

CITY OF ROUND ROCK STREET AND DRAINAGE NOTES:

- ALL TESTING SHALL BE DONE BY AN INDEPENDENT LABORATORY AT THE OWNER'S EXPENSE. ANY RETESTING SHALL BE PAID FOR BY THE CONTRACTOR. A CITY INSPECTOR SHALL BE PRESENT DURING ALL TESTS. TESTING SHALL BE COORDINATED WITH THE CITY INSPECTOR AND HE SHALL BE GIVEN A MINIMUM OF 24 HOURS NOTICE PRIOR TO ANY TESTING. TELEPHONE 218-5555 (INSPECTIONS).
- BACKFILL BEHIND THE CURB SHALL BE COMPACTED TO OBTAIN A MINIMUM OF 95% MAXIMUM DENSITY TO WITHIN 3" OF TOP OF CURB. MATERIAL USED SHALL BE PRIMARILY GRANULAR WITH NO ROCKS LARGER THAN 6" IN THE GREATEST DIMENSION. THE REMAINING 3" SHALL BE CLEAN TOPSOIL FREE FROM ALL CLOUDS AND SUITABLE FOR SUSTAINING PLANT LIFE.
- DEPTH OF COVER FOR ALL CROSSINGS UNDER PAVEMENT INCLUDING GAS, ELECTRIC, TELEPHONE, CABLE TV, WATER SERVICES, ETC., SHALL BE A MINIMUM OF 30" BELOW SUBGRADE.
- STREET RIGHTS-OF-WAY SHALL BE GRADED AT A SLOPE OF 1/4" PER FOOT TOWARD THE CURB UNLESS OTHERWISE INDICATED. HOWEVER, IN NO CASE SHALL THE WIDTH OF RIGHT-OF-WAY AT 1/4" PER FOOT SLOPE BE LESS THAN 10 FEET UNLESS A SPECIFIC REQUEST FOR AN ALTERNATE GRADING SCHEME IS MADE TO AND ACCEPTED BY THE CITY OF ROUND ROCK ENGINEERING AND DEVELOPMENT SERVICES DEPARTMENT.
- BARRICADES BUILT TO CITY OF ROUND ROCK STANDARDS SHALL BE CONSTRUCTED ON ALL DEAD-END STREETS AND AS NECESSARY DURING CONSTRUCTION TO MAINTAIN JOB AND PUBLIC.
- ALL R.C.P. SHALL BE MINIMUM CLASS III.
- THE SUBGRADE MATERIAL FOR THE STREETS SHOWN HEREIN WAS TESTED BY ECS SOUTHWEST, LLP. AND THE PAVING SECTIONS DESIGNED IN ACCORDANCE WITH THE CURRENT CITY OF ROUND ROCK DESIGN CRITERIA. THE PAVING SECTIONS ARE TO BE CONSTRUCTED AS FOLLOWS:

STREET	STATION	FLEX. BASE THICKNESS	HMAC THICKNESS	LIME STAB. THICKNESS
NO CITY OF ROUND ROCK STREETS WITH THIS PROJECT				

- THE GEOTECHNICAL ENGINEER SHALL INSPECT THE SUBGRADE FOR COMPLIANCE WITH THE DESIGN ASSUMPTIONS MADE DURING PREPARATION OF THE SOILS REPORT. ANY ADJUSTMENTS THAT ARE REQUIRED SHALL BE MADE THROUGH REVISION OF THE CONSTRUCTION PLAN.
- WHERE PI'S ARE OVER 20, SUBGRADES MUST BE STABILIZED UTILIZING A METHOD ACCEPTABLE TO THE CITY ENGINEER, THE GEOTECHNICAL ENGINEER SHALL RECOMMEND AN APPROPRIATE SUBGRADE STABILIZATION IF SULFATES ARE DETERMINED TO BE PRESENT.

CITY OF ROUND ROCK TRAFFIC MARKING NOTES:

- ANY METHODS, STREET MARKINGS AND SIGNAGE NECESSARY FOR WARNING MOTORISTS, WARNING PEDESTRIANS OR DIVERTING TRAFFIC DURING CONSTRUCTION SHALL CONFORM TO THE TEXAS MANUAL OF UNIFORM TRAFFIC CONTROL DEVICES FOR STREETS AND HIGHWAYS, LATEST EDITION.
- ALL PAVEMENT MARKINGS, MARKERS, PAINT, TRAFFIC BUTTONS, TRAFFIC CONTROLS AND SIGNS SHALL BE INSTALLED IN ACCORDANCE WITH THE TEXAS DEPARTMENT OF TRANSPORTATION STANDARD SPECIFICATIONS FOR CONSTRUCTION OF HIGHWAYS, STREETS AND BRIDGES AND, THE TEXAS MANUAL OF UNIFORM TRAFFIC CONTROL DEVICES FOR STREETS AND HIGHWAYS, LATEST EDITIONS.

CITY OF ROUND ROCK EROSION AND SEDIMENTATION CONTROL NOTES:

- EROSION CONTROL MEASURES, SITE WORK AND RESTORATION WORK SHALL BE IN ACCORDANCE WITH THE CITY OF ROUND ROCK EROSION AND SEDIMENTATION CONTROL ORDINANCE.
- ALL SLOPES SHALL BE SODDED OR SEEDED WITH APPROVED GRASS, GRASS MIXTURES OR GROUND COVER SUITABLE TO THE AREA AND SEASON IN WHICH THEY ARE APPLIED.
- SILT FENCES, ROCK BERMS, SEDIMENTATION BASINS AND SIMILARLY RECOGNIZED TECHNIQUES AND MATERIALS SHALL BE EMPLOYED DURING CONSTRUCTION TO PREVENT POINT SOURCE SEDIMENTATION LOADING OF DOWNSTREAM FACILITIES. SUCH INSTALLATION SHALL BE REGULARLY INSPECTED BY THE CITY OF ROUND ROCK FOR EFFECTIVENESS. ADDITIONAL MEASURES MAY BE REQUIRED IF, IN THE OPINION OF THE CITY ENGINEER, THEY ARE WARRANTED.
- ALL TEMPORARY EROSION CONTROL MEASURES SHALL NOT BE REMOVED UNTIL FINAL INSPECTION AND APPROVAL OF THE PROJECT BY THE ENGINEER. IT SHALL BE THE RESPONSIBILITY OF THE CONTRACTOR TO MAINTAIN ALL TEMPORARY EROSION CONTROL STRUCTURES AND TO REMOVE EACH STRUCTURE AS APPROVED BY THE ENGINEER.
- ALL MUD, DIRT, ROCKS, DEBRIS, ETC., SPILLED, TRACKED OR OTHERWISE DEPOSITED ON EXISTING PAVED STREETS, DRIVES AND AREAS USED BY THE PUBLIC SHALL BE CLEANED UP IMMEDIATELY.

CITY OF ROUND ROCK WATER AND WASTE WATER NOTES:

- PIPE MATERIAL FOR WATER MAINS SHALL BE PVC (AWWA C-900, MIN. CLASS 200), OR DUCTILE IRON (AWWA C-100, MIN. CLASS 200). WATER SERVICES (2" OR LESS) SHALL BE POLYETHYLENE TUBING (BLACK, 200 PSI, DR 9).
- PIPE MATERIAL FOR PRESSURE WASTEWATER MAINS SHALL BE PVC (AWWA C-900, MIN. CLASS 150), OR DUCTILE IRON (AWWA C-100, MIN. CLASS 200). PIPE MATERIAL FOR GRAVITY WASTEWATER MAINS SHALL BE PVC (ASTM D2241 OR D3034, MAX. DR-26), DUCTILE IRON (AWWA C-100, MIN. CLASS 200).
- UNLESS OTHERWISE ACCEPTED BY THE CITY ENGINEER, DEPTH OF COVER FOR ALL LINES OUT OF THE PAVEMENT SHALL BE 42" MIN., AND DEPTH OF COVER FOR ALL LINES UNDER PAVEMENT SHALL BE A MIN. OF 30" BELOW SUBGRADE.
- ALL FIRE HYDRANT LEADS SHALL BE DUCTILE IRON PIPE (AWWA C-100, MIN. CLASS 200).
- ALL IRON PIPE AND FITTINGS SHALL BE WRAPPED WITH MINIMUM 8-MIL POLYETHYLENE AND SEALED WITH DUCT TAPE OR EQUAL ACCEPTED BY THE CITY ENGINEER.
- THE CONTRACTOR SHALL CONTACT THE CITY INSPECTOR AT 218-5555 TO COORDINATE UTILITY TIE-INS AND NOTIFY HIM AT LEAST 48 HOURS PRIOR TO CONNECTING TO EXISTING LINES.
- ALL MANHOLES SHALL BE CONCRETE WITH CAST IRON RING AND COVER. ALL MANHOLES LOCATED OUTSIDE OF THE PAVEMENT SHALL HAVE BOLTED COVERS. TAPPING OF FIBERGLASS MANHOLES SHALL NOT BE ALLOWED.
- THE CONTRACTOR MUST OBTAIN A BULK WATER PERMIT OR PURCHASE AND INSTALL A WATER METER FOR ALL WATER USED DURING CONSTRUCTION. A COPY OF THIS PERMIT MUST BE CARRIED AT ALL TIMES BY ALL WHO USE WATER.
- LINE FLUSHING OR ANY ACTIVITY USING A LARGE QUANTITY OF WATER MUST BE SCHEDULED WITH THE WATER & WASTEWATER SUPERINTENDENT, TELEPHONE 218-5555.
- THE CONTRACTOR, AT HIS EXPENSE, SHALL PERFORM STERILIZATION OF ALL POTABLE WATER LINES CONSTRUCTED AND SHALL PROVIDE ALL EQUIPMENT (INCLUDING TEST GAUGES), SUPPLIES (INCLUDING CONCENTRATED CHLORINE DISINFECTING MATERIAL), AND NECESSARY LABOR REQUIRED FOR THE STERILIZATION PROCEDURE. THE STERILIZATION PROCEDURE SHALL BE MONITORED BY CITY OF ROUND ROCK PERSONNEL. WATER SAMPLES WILL BE COLLECTED BY THE CITY OF ROUND ROCK TO VERIFY EACH TREATED LINE HAS ATTAINED AN INITIAL CHLORINE CONCENTRATION OF 50 PPM. WHERE MEANS OF FLUSHING IS NECESSARY, THE CONTRACTOR, AT HIS EXPENSE, SHALL PROVIDE FLUSHING DEVICES AND REMOVE SAID DEVICES PRIOR TO FINAL ACCEPTANCE BY THE CITY OF ROUND ROCK.
- SAMPLING TAPS SHALL BE BROUGHT UP TO 3 FEET ABOVE GRADE AND SHALL BE EASILY ACCESSIBLE FOR CITY PERSONNEL. AT THE CONTRACTOR'S REQUEST, AND IN HIS PRESENCE, SAMPLES FOR BACTERIOLOGICAL TESTING WILL BE COLLECTED BY THE CITY OF ROUND ROCK NOT LESS THAN 24 HOURS AFTER THE TREATED LINE HAS BEEN FLUSHED OF THE CONCENTRATED CHLORINE SOLUTION AND CHARGED WITH WATER APPROVED BY THE CITY. THE CONTRACTOR SHALL SUPPLY A CHECK OR MONEY ORDER, PAYABLE TO THE CITY OF ROUND ROCK, TO COVER THE FEE CHARGED FOR TESTING EACH WATER SAMPLE. CITY OF ROUND ROCK FEE AMOUNTS MAY BE OBTAINED BY CALLING THE ENGINEERING AND DEVELOPMENT SERVICES DEPARTMENT AT 218-5555.
- THE CONTRACTOR, AT HIS EXPENSE, SHALL PERFORM QUALITY TESTING FOR ALL WASTEWATER PIPE INSTALLED AND PRESSURE PIPE HYDROSTATIC TESTING OF ALL WATER LINES CONSTRUCTED AND SHALL PROVIDE ALL EQUIPMENT (INCLUDING PUMPS AND GAUGES), SUPPLIES AND LABOR NECESSARY TO PERFORM THE TESTS. QUALITY AND PRESSURE TESTING SHALL BE MONITORED BY CITY OF ROUND ROCK PERSONNEL.
- THE CONTRACTOR SHALL COORDINATE TESTING WITH THE CITY OF INSPECTOR AND PROVIDE NO LESS THAN 24 HOURS NOTICE PRIOR TO PERFORMING STERILIZATION, QUALITY TESTING OR PRESSURE TESTING.
- THE CONTRACTOR SHALL NOT OPEN OR CLOSE ANY VALVES UNLESS AUTHORIZED BY THE CITY OF ROUND ROCK.
- ALL VALVE BOXES AND COVERS SHALL BE CAST IRON.
- ALL WATER SERVICE, WASTEWATER SERVICE AND VALVE LOCATIONS SHALL BE APPROPRIATELY MARKED AS FOLLOWS:

WATER SERVICE	"W" ON TOP OF CURB
WASTEWATER SERVICE	"S" ON TOP OF CURB
VALVE	"V" ON FACE OF CURB
- TOOLS FOR MARKING THE CURB SHALL BE PROVIDED BY THE CONTRACTOR. OTHER APPROPRIATE MEANS OF MARKING SERVICE AND VALVE LOCATIONS SHALL BE PROVIDED IN AREAS WITHOUT CURBS. SUCH MEANS OF MARKING SHALL BE AS SPECIFIED BY THE ENGINEER AND ACCEPTED BY THE CITY OF ROUND ROCK.
- CONTACT CITY OF ROUND ROCK ENGINEERING AND DEVELOPMENT SERVICES DEPARTMENT AT 218-5555 FOR ASSISTANCE IN OBTAINING EXISTING WATER AND WASTEWATER LOCATIONS.
- THE CITY OF ROUND ROCK FIRE DEPARTMENT SHALL BE NOTIFIED 48 HOURS PRIOR TO TESTING OF ANY BUILDING SPRINKLER PIPING IN ORDER THAT THE FIRE DEPARTMENT MAY MONITOR SUCH TESTING.
- SAND, AS DESCRIBED IN SPECIFICATION ITEM 510 PIPE, SHALL NOT BE USED AS BEDDING FOR WATER AND WASTEWATER LINES. ACCEPTABLE BEDDING MATERIALS ARE PIPE BEDDING STONE, PEA GRAVEL AND IN LIEU OF SAND, A NATURALLY OCCURRING OR MANUFACTURED STONE MATERIAL CONFORMING TO ASTM C33 FOR STONE QUALITY AND MEETING THE FOLLOWING GRADATION SPECIFICATION:

SIEVE SIZE	PERCENT RETAINED BY WEIGHT
1/2"	0
3/8"	0-2
#4	40-85
#10	95-100
- THE CONTRACTOR IS HEREBY NOTIFIED THAT CONNECTING TO, SHUTTING DOWN, OR TERMINATING EXISTING UTILITY LINES MAY HAVE TO OCCUR AT OFF-PEAK HOURS. SUCH HOURS ARE USUALLY OUTSIDE NORMAL WORKING HOURS AND POSSIBLY BETWEEN 12 A.M. AND 6 A.M.
- ALL WASTEWATER CONSTRUCTION SHALL BE IN ACCORDANCE WITH THE TEXAS COMMISSION ON ENVIRONMENTAL QUALITY (TCEQ) REGULATIONS, 30 TAC CHAPTER 213 AND 317, AS APPLICABLE. WHENEVER TCEQ AND CITY OF ROUND ROCK SPECIFICATIONS CONFLICT, THE MORE STRINGENT SHALL APPLY.

ROUND ROCK FIRE DEPARTMENT NOTES

- ALL WEATHER ACCESS ROADS MADE OF (CONCRETE OR ASPHALT) SHALL BE IN PLACE BEFORE BRINGING COMBUSTIBLE MATERIALS ON THE JOBSITE. FIRE ACCESS ROAD MUST SUPPORT 80,000 LBS. SITE HYDRANTS SHALL ALSO BE IN-SERVICE.
- THE GRADE THROUGH THE FIRE LANE ACCESS SHALL NOT BE GREATER THAN > 7% PERCENT, AND THE GRADE BREAKS NOT GREATER >3% PERCENT.
- THE VERTICAL CLEARANCE OVER A DESIGNATED FIRE LANE SHALL NOT BE LESS THAN 13'6".
- A 3-FOOT CLEAR SPACE SHALL MAINTAINED AROUND THE CIRCUMFERENCE OF ALL FIRE HYDRANTS.

LANGAN

Langan Engineering and Environmental Services, Inc.

9606 N. Mopac Expressway, Suite 110
Austin, TX 78759

T: 737.289.7800 F: 737.289.7801 www.langan.com
TBPE FIRM REG. #F-13709

CoRR Tracking Number : SDP23-00054

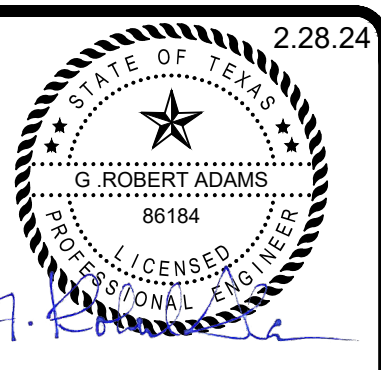

REVISIONS

JADE AT CHISHOLM TRAIL
 392 APARTMENT UNITS IN ROUND ROCK, TEXAS
 GLENRIDGE DEVELOPMENT

PERMIT SET
 ISSUED 02-28-2024

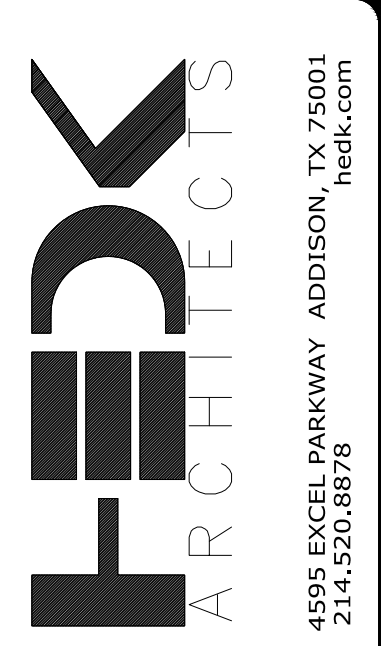

DATE
02-28-2024

PROJECT
22137

SHEET NUMBER
C1.02

CITY OF ROUND ROCK GENERAL NOTES

COPYRIGHT © HEDK Architects ALL RIGHTS RESERVED

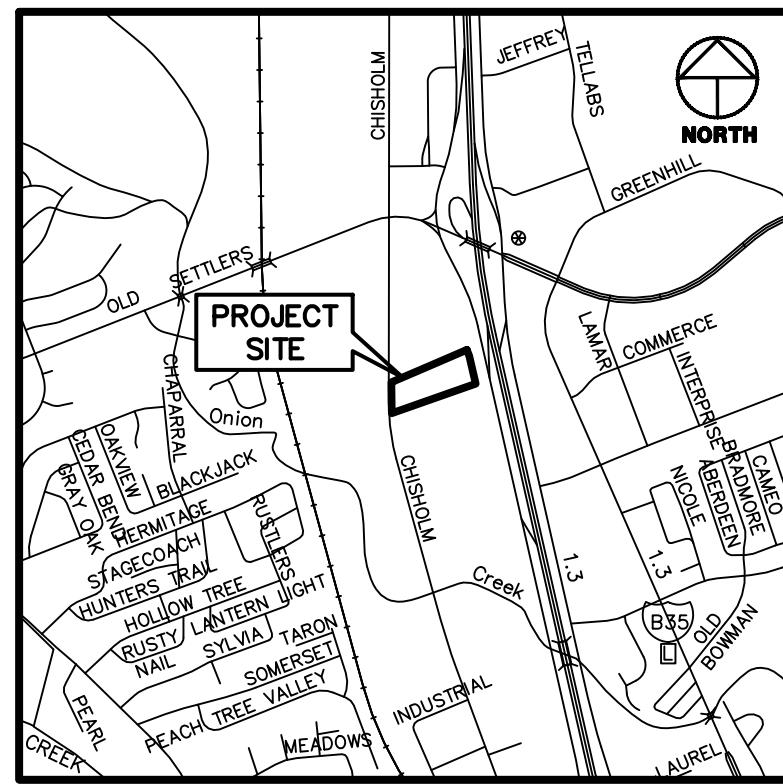

CITY OF ROUND ROCK, WILLIAMSON COUNTY, TEXAS
VICINITY MAP
 SCALE: 1" = 2,000'



GRAPHIC SCALE: 1" = 40'

TEMPORARY BENCHMARK "A" ELEVATION - 780.98

BEING A CUT BOX ON A CURB LOCATED ON THE EAST RIGHT OF WAY OF CHISHOLM TRAIL ROAD, APPROXIMATELY 1,300 FEET FROM THE INTERSECTION WITH WEST OLD SETTLER'S BLVD.

TEMPORARY BENCHMARK "B" ELEVATION - 780.13

BEING A CUT BOX ON A CURB LOCATED ON THE SOUTHWEST RIGHT OF WAY OF S I-35 FRONTAGE RD, APPROXIMATELY 820 FEET FROM THE INTERSECTION WITH WEST OLD SETTLER'S BLVD.

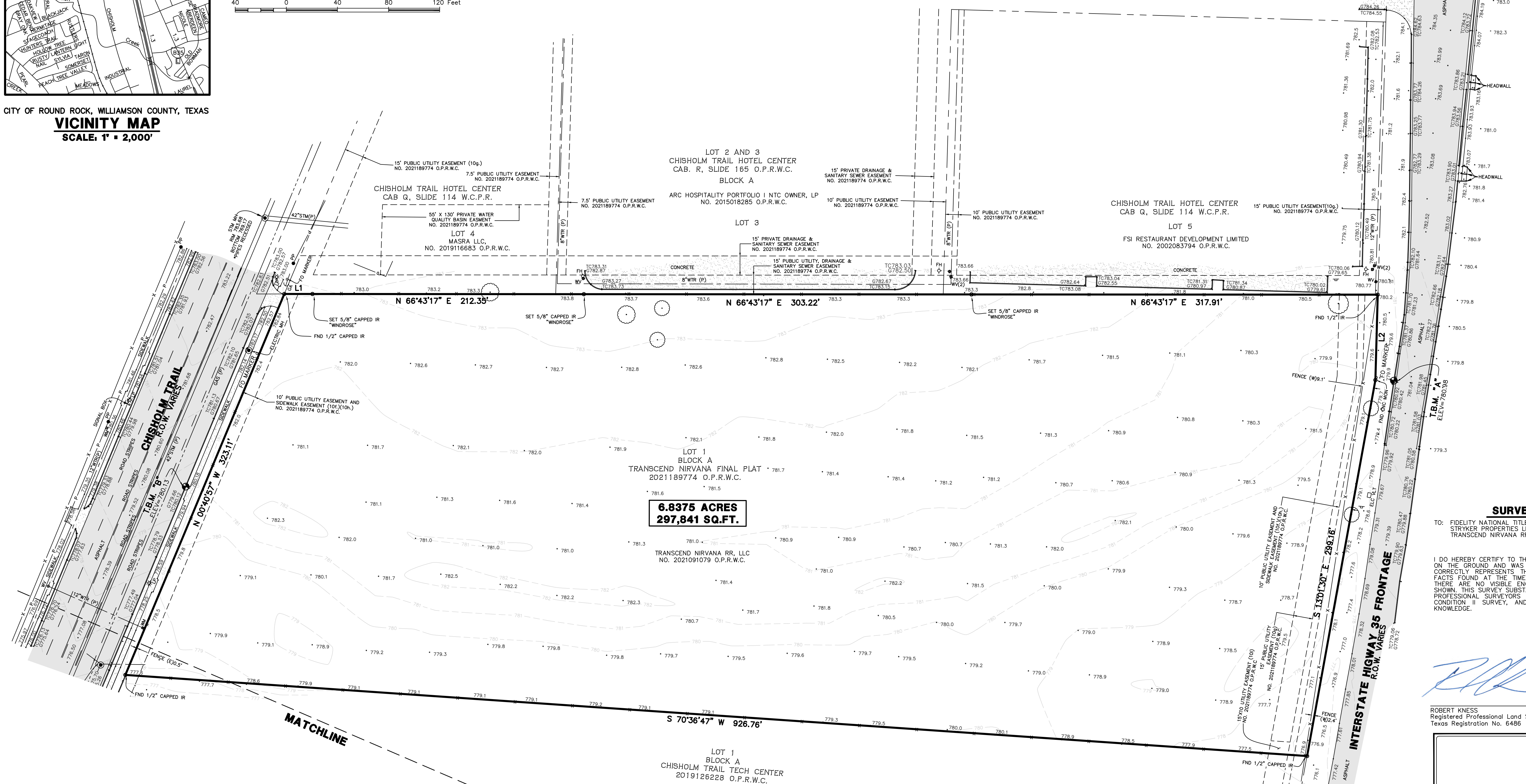

SURVEYOR'S CERTIFICATION

TO: FIDELITY NATIONAL TITLE INSURANCE COMPANY
 STRYKER PROPERTIES LLC
 TRANSCEND NIRVANA RR, LLC.

I DO HEREBY CERTIFY TO THE ABOVE LISTED THAT THIS SURVEY WAS THIS DAY MADE ON THE GROUND AND WAS PERFORMED UNDER MY SUPERVISION, THAT THIS PLAT CORRECTLY REPRESENTS THE PROPERTY LEGALLY DESCRIBED HEREON, THAT THE FACTS FOUND AT THE TIME OF THIS SURVEY SHOW THE IMPROVEMENTS AND THAT THERE ARE NO VISIBLE ENCROACHMENTS APPARENT ON THE GROUND, EXCEPT AS SHOWN. THIS SURVEY SUBSTANTIALLY CONFORMS TO THE CURRENT TEXAS SOCIETY OF PROFESSIONAL SURVEYORS' STANDARDS AND SPECIFICATIONS FOR A CATEGORY 1A, CONDITION II SURVEY, AND CATEGORY 6, CONDITION II, TO THE BEST OF MY KNOWLEDGE.

[Signature]
ROBERT KNESS
 Registered Professional Land Surveyor
 Texas Registration No. 6486

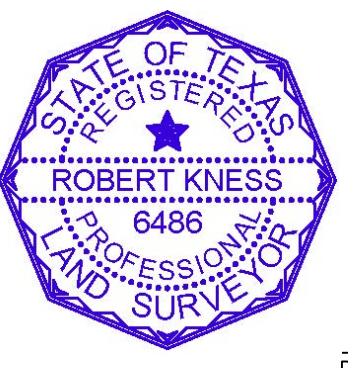

05/09/22
 DATE

LEGEND

- * SOME OF THESE ELEMENTS MAY NOT BE USED ON THIS SURVEY
- BO - BOLLARD
 - HC - HANDICAP
 - GM - GAS METER
 - GV - GAS VALVE
 - CH - FIRE HYDRANT
 - WM - WATER METER
 - WV - WATER VALVE
 - CV - IRRIGATION CONTROL VALVE
 - GI - GRATE INLET
 - MI - MANHOLE
 - CO - CLEANOUT
 - TP - TELEPHONE PEDESTAL
 - EB - ELECTRIC BOX
 - TB - TRAFFIC SIGNAL BOX
 - LP - LIGHT POLE
 - PL - TRAFFIC LIGHT POLE
 - GL - GROUND/SPOT LIGHT
 - PP - POWER POLE
 - PP/T - POWER POLE W/TRANSFORMER
 - PP/AL - POWER POLE W/LIGHT
 - PP/CT - POWER POLE W/CONDUIT
 - MP - METER POLE
 - SP - SERVICE POLE
 - GA - GUY ANCHOR
 - OP - OVERHEAD POWER LINE
 - BW - BARBED WIRE FENCE
 - WI - WROUGHT IRON FENCE
 - WF - WOOD FENCE
 - CF - CHAINLINK FENCE
 - GP - GATE POST
 - AP - APPROXIMATE
 - PL - LIGHT POLE
 - PL - HIGHBANK
 - PL - SIGN
 - PLM - PIPELINE MARKER
 - UCS - UNDERGROUND CABLE SIGN
 - CTL - CATHODIC TEST LEAD
 - MW - MONITORING WELL
 - P - PIN FLAG/PAINT MARK
 - TC - TOP OF CURB
 - G - GUTTER
 - TG - TOP OF GRATE
 - FL - FLOW LINE
 - HB - HIGHBANK
 - SAN - SANITARY SEWER
 - STM - STORM SEWER
 - CMP - CORRUGATED METAL PIPE
 - CPP - CORRUGATED PLASTIC PIPE
 - RCP - REINFORCED CONCRETE PIPE
 - TEL - TELEPHONE
 - SWBT - SOUTHWESTERN BELL TELEPHONE CO.
 - WTR - WATER
 - UG - UNDERGROUND
 - W.C.C.F. - WILLIAMSON COUNTY CLERK FILE
 - W.C.D.R. - WILLIAMSON COUNTY DEED RECORDS
 - W.C.P.R. - WILLIAMSON COUNTY PLAT RECORDS
 - O.P.W.C. - OFFICIAL PUBLIC RECORDS WILLIAMSON COUNTY
 - IP - IRON PIPE
 - IR - IRON ROD
 - NO - NUMBER
 - PG - PAGE
 - R.O.W. - RIGHT-OF-WAY
 - SQ. FT. - SQUARE FEET
 - VOL. - VOLUME
 - F.C. - FILM CODE
 - B.L. - BUILDING LINE
 - U.E. - UTILITY EASEMENT
 - T - TREE/SHRUB
 - P.O.B. - POINT OF BEGINNING

TREE TABLE

POINTS/FEET	TYPE
11005 7"	HACKBERRY
20003 6"	HACKBERRY(2)
20005 6"	HACKBERRY(4)
20007 8"	MESQUITE(3)
20009 6"	CHINABERRY
20010 6"	MESQUITE(3)
20011 7"	MESQUITE(2)

LINE TABLE

LINE	BEARING	DISTANCE
L1	N 66°43'17" E	22.03'
L2	S 21°45'02" E	66.85'

REVISIONS

DATE	REASON	BY
5-5-2022	ADDED ADDITIONAL TOPO	CG
6-15-2022	ADDED TREES AND TREE TABLE	DB
6-21-2022	ADDED TREES AND SIGN	CG
3-17-2023	ADDED EASEMENTS	DB
04-28-2023	ADDED ADDITIONAL TOPO	JE

WINDROSE
 LAND SURVEYING & PLATTING
 11111 RICHMOND AVE. STE 150 | HOUSTON, TX 77082 | 713-458-2281
 FIRM REGISTRATION NO. 10108800 | WINDROSESERVICES.COM

TOPOGRAPHIC LAND TITLE SURVEY OF
 LOT 1 BLOCK A
 TRANSCEND NIRVANA
 NO. 2021189774 W.C.P.R.
 SITUATED IN THE
 DAVID CURRY SURVEY
 ABSTRACT NO. 130
 CITY OF ROUND ROCK, WILLIAMSON COUNTY, TEXAS

FIELD BY: ZH/TB/RG CHECKED BY: CC JOB NO. 57651
 DRAWN BY: RN DATE: 4/06/2022 SHEET NO. 1 OF 2

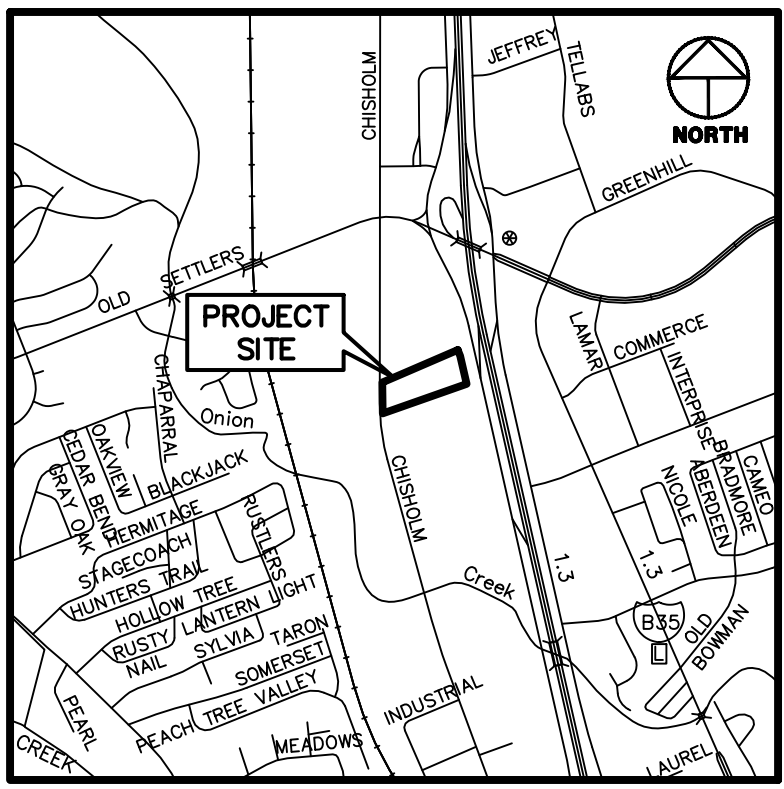

CITY OF ROUND ROCK, WILLIAMSON COUNTY, TEXAS
VICINITY MAP

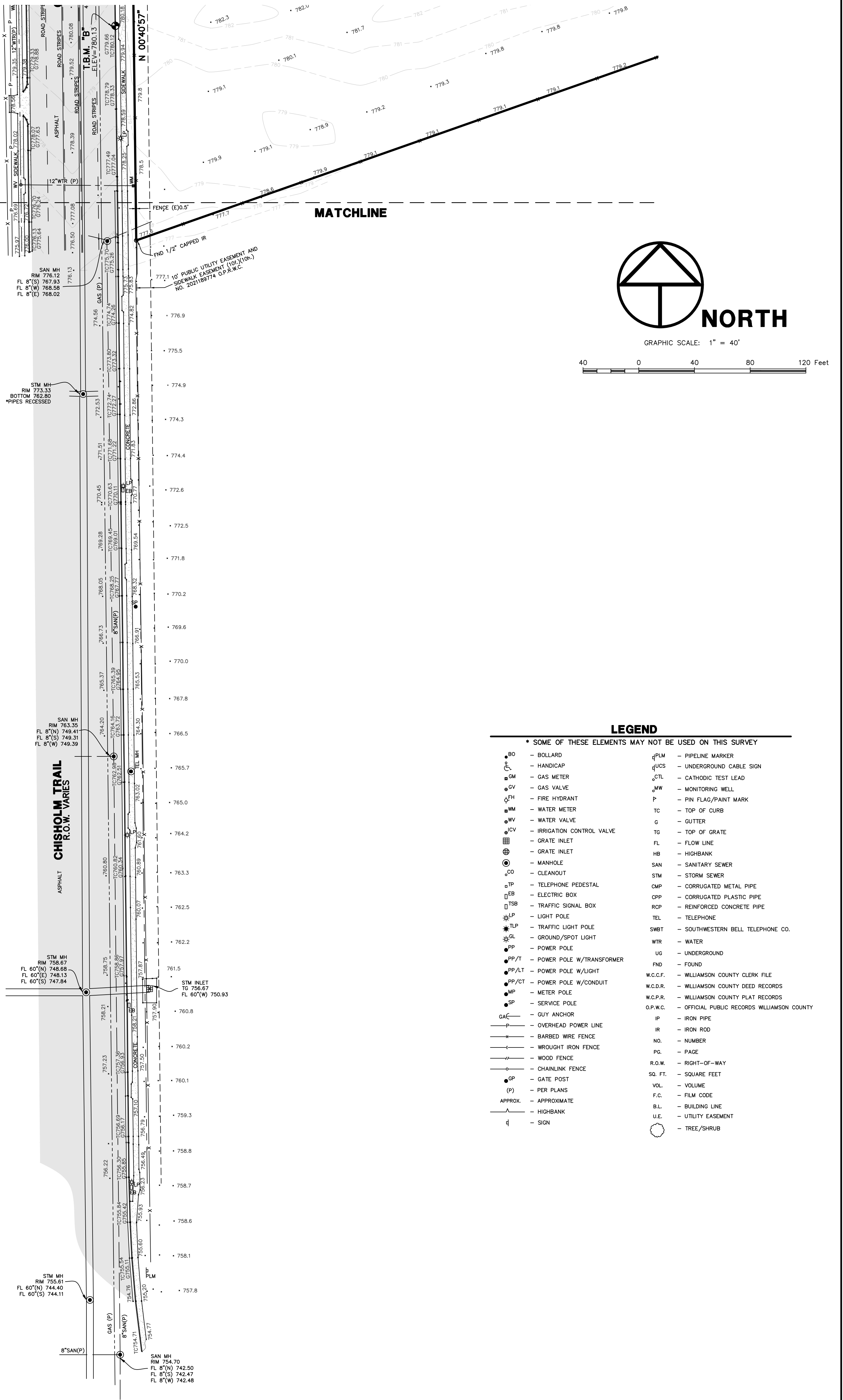

GRAPHIC SCALE: 1" = 40'

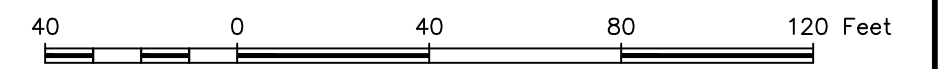

GENERAL NOTES

- SURVEYOR DID NOT ABSTRACT SUBJECT PROPERTY. THIS SURVEY WAS PREPARED WITH INFORMATION CONTAINED IN TITLE COMMITMENT OF NO. AUT-22-054-170992200196A OF FIDELITY NATIONAL TITLE INSURANCE COMPANY, EFFECTIVE DATE OF FEBRUARY 24, 2022, ISSUED DATE OF MARCH 4, 2022, AND IS SUBJECT TO THE LIMITATIONS OF THAT COMMITMENT.
- BEARINGS WERE BASED ON THE TEXAS STATE PLANE COORDINATE SYSTEM, CENTRAL ZONE (NAD 83). ALL DISTANCES SHOWN HEREON ARE SURFACE DISTANCES AND MAY BE BROUGHT TO GRID BY APPLYING THE FOLLOWING SCALE FACTOR: 0.99988148.
- ACCORDING TO THE FEDERAL EMERGENCY MANAGEMENT AGENCY (FEMA), FLOOD INSURANCE RATE MAP (FIRM) FOR WILLIAMSON COUNTY, TEXAS, MAP NO. 48491C0487F REVISED/DATED DECEMBER 20, 2019, THE SUBJECT TRACT APPEARS TO LIE WITHIN UNSHADED ZONE "X". THIS DETERMINATION WAS DONE BY GRAPHIC PLOTTING AND IS APPROXIMATE ONLY, AND HAS NOT BEEN FIELD VERIFIED. THIS FLOOD STATEMENT DOES NOT IMPLY THAT THE PROPERTY OR STRUCTURES THEREON WILL BE FREE FROM FLOODING OR FLOOD DAMAGE. ON RARE OCCASIONS FLOODS CAN AND WILL OCCUR AND FLOOD HEIGHTS MAY BE INCREASED BY MAN-MADE OR NATURAL CAUSES. THIS FLOOD STATEMENT SHALL NOT CREATE LIABILITY ON THE PART OF WINDROSE LAND SERVICES.
- READILY VISIBLE IMPROVEMENTS AND UTILITIES WERE LOCATED WITH THIS SURVEY. NO SUBSURFACE PROBING, EXCAVATION OR EXPLORATION WAS PERFORMED BY WINDROSE LAND SERVICES.
- ENVIRONMENTAL AND DRAINAGE ISSUES ARE BEYOND THE SCOPE OF THIS SURVEY.
- THE SQUARE FOOTAGE TOTALS SHOWN HEREON ARE BASED ON THE MATHEMATICAL CLOSURE OF THE COURSES AND DISTANCES REFLECTED ON THE SURVEY. IT DOES NOT INCLUDE TOLERANCES THAT MAY BE PRESENT DUE TO THE POSITIONAL ACCURACY OF THE BOUNDARY MONUMENTATION.
- FENCES SHOWN HEREON WITH DIMENSIONAL TIES ARE SHOWN WHERE THEY ARE PHYSICALLY MEASURED. THE FENCE MAY MEANDER BETWEEN MEASURED LOCATIONS.
- THE WORD "CERTIFY" OR "CERTIFICATE" AS SHOWN AND USED HEREON MEANS AN EXPRESSION OF PROFESSIONAL OPINION REGARDING THE FACTS OF THE SURVEY AND DOES NOT CONSTITUTE A WARRANTY OR GUARANTEE EXPRESSED OR IMPLIED.
- ELEVATIONS SHOWN TO THE NEAREST TENTH ARE NATURAL GROUND SURFACE ELEVATIONS AND ELEVATIONS SHOWN TO THE NEAREST HUNDREDTH ARE SOLID SURFACE ELEVATIONS.
- GAS, SANITARY, STORM, TELEPHONE AND WATER LINES SHOWN HEREON ARE BASED ON UTILITY PLANS ACQUIRED FROM CITY OF ROUND ROCK, TX DOT, WILLIAMSON CO AND WERE FIELD VERIFIED WHERE POSSIBLE. OTHER UTILITY PLANS OR INFORMATION MAY EXIST NOT KNOWN TO THIS COMPANY.
- SURVEYOR DID NOT PHYSICALLY ENTER MANHOLES. UNDERGROUND PIPE SIZES WERE DETERMINED BY A "MEASURE DOWN" METHOD FROM TOP OF MANHOLE RIM OR TOP OF GRATE OR TOP OF CURB AND WERE COMPARED WITH UTILITY PLANS WHERE POSSIBLE.
- SURVEYOR HAS CONTACTED DIGTESS FOR LOCATION OF BURIED UTILITY AND FIBER OPTIC LINES PRIOR TO THIS SURVEY. SURVEYOR CANNOT CERTIFY OR GUARANTEE THE ACCURACY OR COMPLETENESS OF THIS REQUEST. OTHER UNDERGROUND UTILITY LINES MAY EXIST NOT KNOWN TO THIS COMPANY. IT IS THE CONTRACTOR'S RESPONSIBILITY TO CONTACT DIGTESS OR OTHER UTILITY NOTIFICATION SERVICES FOR LOCATION OF UNDERGROUND UTILITIES, PRIOR TO CONSTRUCTION.
- ELEVATIONS HEREON ARE BASED UPON A NGS OPUS SOLUTION DERIVED FROM ON-SITE STATIC GPS OBSERVATIONS CONDUCTED AT THE TIME OF SURVEY. ACCORDING TO THE NGS OPUS REPORT, THE FOLLOWING CORS STATIONS WERE USED: DGS763 TXBU BURNETT CORS ARP, DGS761 TXBS BASTROP CORS ARP, DM4151 TXBT BELTON CORS ARP. THE NEAREST NGS PUBLISHED CONTROL POINT IS 8M0801 S 1304. (NAVD88, COMPUTED USING GEOD18)

SCHEDULE B NOTES

- THE FOLLOWING RESTRICTIVE COVENANTS OF RECORD ITEMIZED BELOW DOCUMENT NO. 2021189774 (PLAT), OFFICIAL PUBLIC RECORDS OF WILLIAMSON COUNTY, TEXAS.
- EASEMENT(S) FOR THE PURPOSE(S) SHOWN BELOW AND RIGHTS INCIDENTAL THERETO AS DELINEATED OR AS OFFERED FOR DEDICATION, ON THE MAP OF SAID TRACT/PLAT: PUBLIC UTILITY EASEMENT AND SIDEWALK EASEMENT 10' ABUTTING AND ALONG THE STREET SIDE PROPERTY LINE(S) DOCUMENT NO. 2021189774, OFFICIAL PUBLIC RECORDS OF WILLIAMSON COUNTY, TEXAS. (AFFECTS SUBJECT TRACT, SHOWN HEREON)
- EASEMENT(S) FOR THE PURPOSE(S) SHOWN BELOW AND RIGHTS INCIDENTAL THERETO AS DELINEATED OR AS OFFERED FOR DEDICATION, ON THE MAP OF SAID TRACT/PLAT: PUBLIC UTILITY EASEMENT 15' ABUTTING AND ALONG THE IH35 RIGHT-OF-WAY PROPERTY LINE(S) DOCUMENT NO. 2021189774, OFFICIAL PUBLIC RECORDS OF WILLIAMSON COUNTY, TEXAS. (AFFECTS SUBJECT TRACT, SHOWN HEREON)
- EASEMENT(S) FOR THE PURPOSE(S) SHOWN BELOW AND RIGHTS INCIDENTAL THERETO AS DELINEATED OR AS OFFERED FOR DEDICATION, ON THE MAP OF SAID TRACT/PLAT: SIDEWALK EASEMENT 10' ABUTTING AND ALONG THE IH35 RIGHT-OF-WAY PROPERTY LINE(S) DOCUMENT NO. 2021189774, OFFICIAL PUBLIC RECORDS OF WILLIAMSON COUNTY, TEXAS. (AFFECTS SUBJECT TRACT, SHOWN HEREON)
- EASEMENT(S) FOR THE PURPOSE(S) SHOWN BELOW AND RIGHTS INCIDENTAL THERETO AS DELINEATED OR AS OFFERED FOR DEDICATION, ON THE MAP OF SAID TRACT/PLAT: UTILITY EASEMENT 15' X 10' OVER THE SOUTHEAST PORTION OF THE SUBJECT PROPERTY DOCUMENT NO. 2021189774, OFFICIAL PUBLIC RECORDS OF WILLIAMSON COUNTY, TEXAS. (AFFECTS SUBJECT TRACT, SHOWN HEREON)
- THE RIGHT TO PROHIBIT, LIMIT, RESTRICT, OR CONTROL ACCESS TO I.H. 35, AS SET OUT IN VOLUME 423, PAGE 71, DEED RECORDS OF WILLIAMSON COUNTY, TEXAS. (AFFECTS SUBJECT TRACT, NON SURVEYABLE)

LEGEND

* SOME OF THESE ELEMENTS MAY NOT BE USED ON THIS SURVEY

BO	BOLLARD	PLM	PIPELINE MARKER
HC	HANDICAP	UCS	UNDERGROUND CABLE SIGN
GM	GAS METER	CTL	CATHODIC TEST LEAD
GV	GAS VALVE	MW	MONITORING WELL
FH	FIRE HYDRANT	P	PIN FLAG/PAIN MARK
WM	WATER METER	TC	TOP OF CURB
WV	WATER VALVE	G	GUTTER
ICV	IRRIGATION CONTROL VALVE	TG	TOP OF GRATE
GI	GRATE INLET	FL	FLOW LINE
MB	MANHOLE	HB	HIGHBANK
CO	CLEANOUT	SN	SANITARY SEWER
TP	TELEPHONE PEDESTAL	STM	STORM SEWER
EB	ELECTRIC BOX	CMP	CORRUGATED METAL PIPE
TSB	TRAFFIC SIGNAL BOX	CPP	CORRUGATED PLASTIC PIPE
LP	LIGHT POLE	RCP	REINFORCED CONCRETE PIPE
TLP	TRAFFIC LIGHT POLE	TEL	TELEPHONE
GL	GROUND/SPOT LIGHT	SWBT	SOUTHWESTERN BELL TELEPHONE CO.
PP	POWER POLE	WTR	WATER
PP/T	POWER POLE W/TRANSFORMER	UG	UNDERGROUND
PP/LT	POWER POLE W/LIGHT	FND	FOUND
PP/CT	POWER POLE W/CONDUIT	W.C.C.F.	WILLIAMSON COUNTY CLERK FILE
MP	METER POLE	W.C.D.R.	WILLIAMSON COUNTY DEED RECORDS
SP	SERVICE POLE	W.C.P.R.	WILLIAMSON COUNTY PLAT RECORDS
GAC	GUY ANCHOR	O.P.W.C.	OFFICIAL PUBLIC RECORDS WILLIAMSON COUNTY
P	OVERHEAD POWER LINE	IP	IRON PIPE
X	BARBED WIRE FENCE	IR	IRON ROD
W	WROUGHT IRON FENCE	NO.	NUMBER
WF	WOOD FENCE	PS.	PAGE
CF	CHAINLINK FENCE	R.O.W.	RIGHT-OF-WAY
GP	GATE POST	SQ. FT.	SQUARE FEET
(P)	PER PLANS	VOL.	VOLUME
APPROX.	APPROXIMATE	F.C.	FIRM CODE
H	HIGHBANK	BL.	BUILDING LINE
d	SIGN	U.E.	UTILITY EASEMENT
		○	TREE/SHRUB

FLOOD INFORMATION NOT TO SCALE

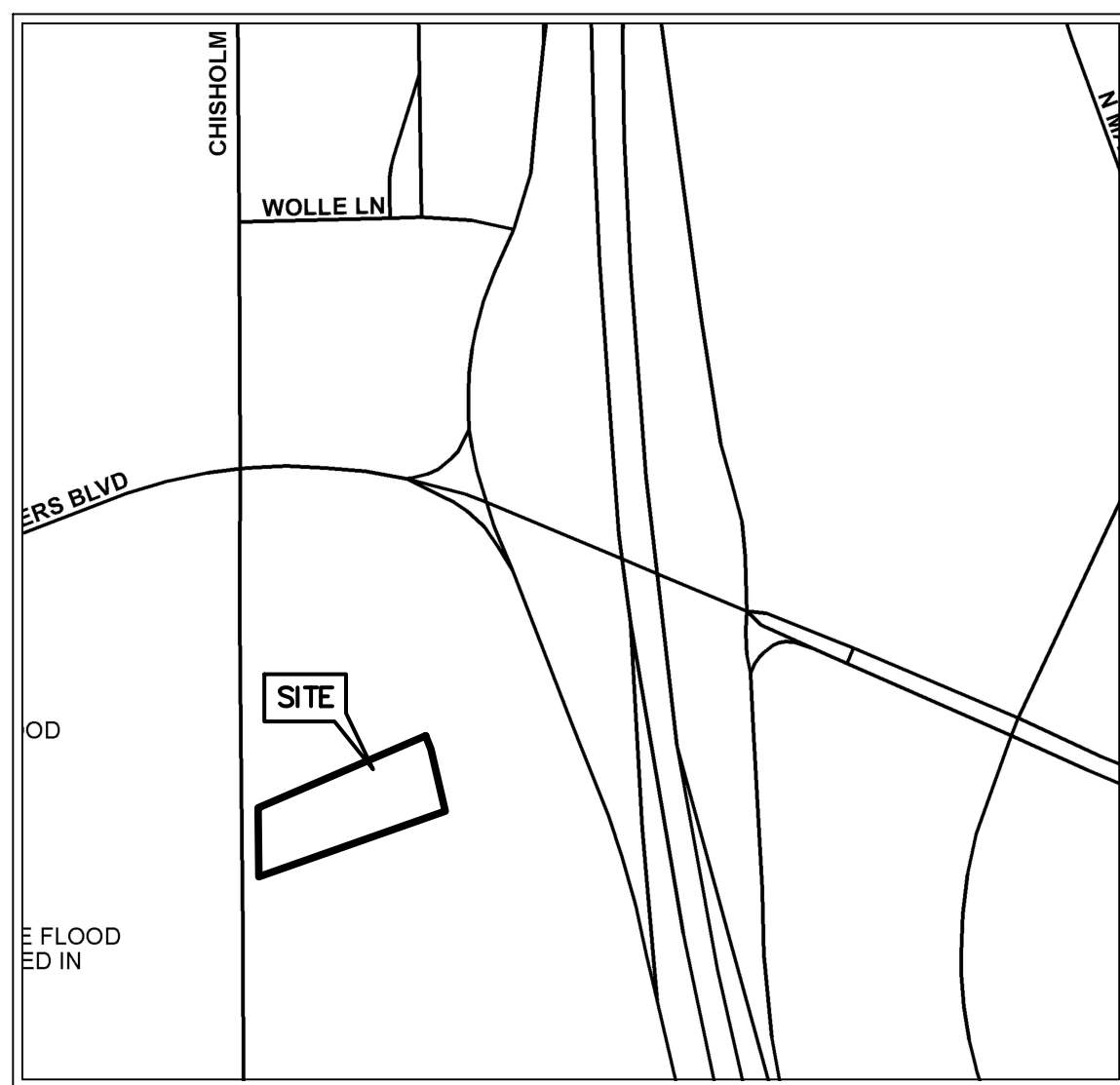

NATIONAL FLOOD INSURANCE FLOOD INSURANCE RATE

WILLIAMSON COUNTY, TEXAS
and Incorporated Areas
Panel 487 of 750

FEMA

Panel Contains:
COMMUNITY NUMBER PANEL SUFFIX
ROUND ROCK CITY OF WILLIAMSON COUNTY 48709 487 0487

VERSION NUMBER 2.3.3.3
MAP NUMBER 48491C0487F
MAP REVISED DECEMBER 20, 2019

DESCRIPTION
LOT 1, BLOCK A
TRANSCEND NIRVANA
NO. 2021189774 W.C.P.R.

WINDROSE
LAND SURVEYING & PLATTING

11111 RICHMOND AVE. STE 150 | HOUSTON, TX 77082 | 713.458.2281
FIRM REGISTRATION NO. 10108800 | WINDROSESERVICES.COM

TOPOGRAPHIC LAND TITLE SURVEY OF
LOT 1 BLOCK A
TRANSCEND NIRVANA
NO. 2021189774 W.C.P.R.
SITUATED IN THE
DAVID CURRY SURVEY
ABSTRACT NO. 130
CITY OF ROUND ROCK, WILLIAMSON COUNTY, TEXAS

COPYRIGHT © WINDROSE LAND SERVICES THIS DOCUMENT IS COPYRIGHTED AND IS AN INSTRUMENT OF SERVICE FOR THE SPECIFIC PROJECT OR TRANSACTION FOR WHICH IT WAS PREPARED. REUSE, COPYING OR MODIFICATION OF THIS DOCUMENT WHETHER IN HARD COPY OR ELECTRONIC FORMAT OTHER THAN FOR THE SPECIFIC PURPOSE INTENDED, WITHOUT WRITTEN PERMISSION FROM WINDROSE LAND SERVICES IS A VIOLATION OF FEDERAL COPYRIGHT LAW.

FILED BY: ZH	CHECKED BY: CC	JOB NO. 57651
DRAWN BY: RN	DATE: 4/06/2022	SHEET NO. 2 OF 2

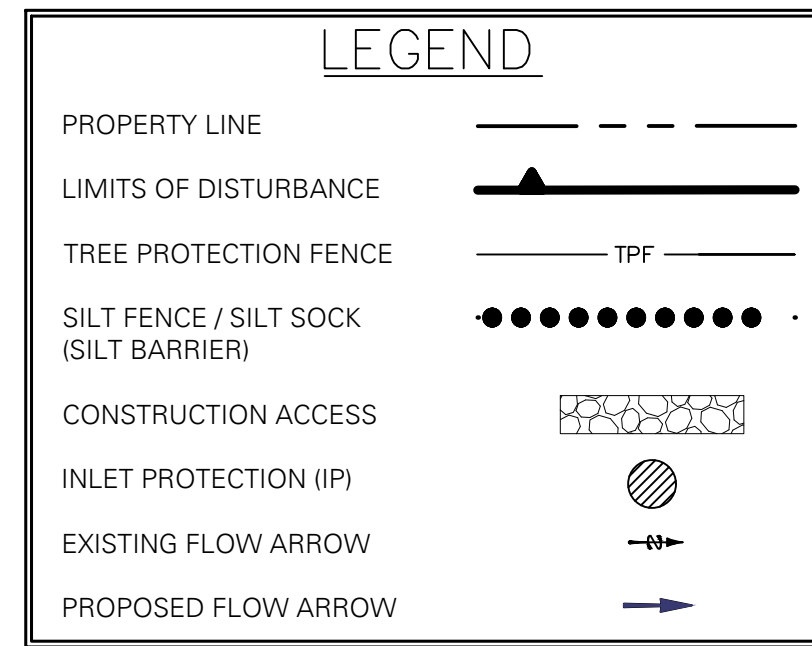
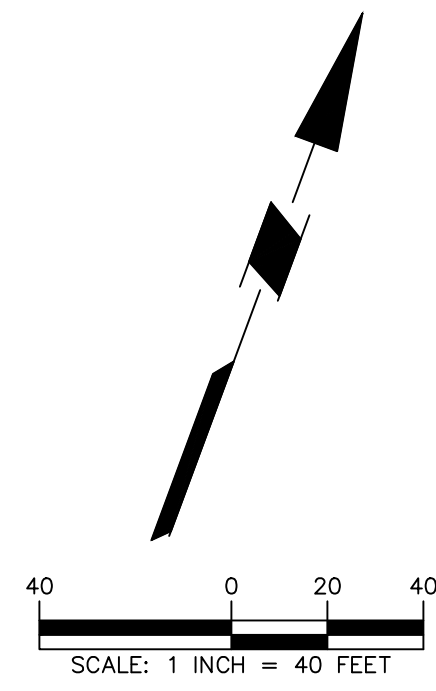

SITE DATA

TOTAL ON-SITE LAND AREA OF SITE: 6.84 AC
 ON-SITE DISTURBED AREA: 6.84 AC
 OFF-SITE DISTURBED AREA: 0.61 AC
 IMPERVIOUS: 5.56 AC
 PERVIOUS: 1.28 AC
 RUNOFF COEFF. PRE-DEV: 0.51
 RUNOFF COEFF. POST-DEV: 0.88

****NOTE - STABILIZATION****

ALL DISTURBED AREAS SHALL BE WATERED, FERTILIZED, AND SEEDED OR SODDED AS NECESSARY AND BY DEFINITION 'MAINTAINED' UNTIL AN ESTABLISHED STAND OF GRASS CAN BE RELEASED TO THE OWNER. REFERENCE TURF RE-ESTABLISHMENT NOTES ON LANDSCAPE SHEETS.

MATERIAL STORAGE - NOTICE TO CONTRACTOR

THE CONTRACTOR SHALL NOTE ON SITE PLAN THE LOCATION OF ALL MATERIAL STORAGE AREAS, EQUIPMENT STORAGE AREAS, PETROLEUM TANKS, SOLID WASTE RECEPTACLES, SANITARY FACILITIES, ANY ON-SITE OR OFF-SITE BORROW OR STOCKPILE AREA, ANY ON-SITE OR OFF-SITE SUPPORT ACTIVITIES (SUCH AS ASPHALT OR CONCRETE PLANTS). CONTRACTOR SHALL ALSO PREPARE, KEEP ON SITE, AND MAINTAIN CURRENT A LIST OF MATERIALS WITH APPROXIMATE QUANTITIES, WHICH ARE STORED ON SITE.

****NOTE - WATER OF THE U.S.****

THERE ARE NO IMPACTS FROM CONSTRUCTION ACTIVITIES TO THE WATERS OF THE U.S. ON THIS SITE.

****NOTE - SWPPP****

CONTRACTOR IS RESPONSIBLE FOR PREPARING AND IMPLEMENTING A STORMWATER POLLUTION PREVENTION PLAN IN ACCORDANCE WITH THE TPDES.

- EROSION CONTROL SEQUENCE**
1. INSTALL SILT BARRIERS AROUND PERIMETER OF PROPERTY AND DISTURBED AREAS AS SHOWN.
 2. INSTALL INLET PROTECTION FOR ALL EXISTING GRATE INLETS, CURB INLETS. CONSTRUCT TEMPORARY CONSTRUCTION ACCESS.
 3. COMMENCE GRUBBING AND REMOVAL OF VEGETATION IN AREA TO RECEIVE CUT OR FILL.
 4. COMMENCE GRADING OPERATION FOR BUILDING PAD PREPARATION.
 5. INSTALL ALL UNDERGROUND UTILITIES.
 6. FINALIZE PAVEMENT SUBGRADE PREPARATION.
 7. INSTALL ALL PROPOSED STORM SEWER PIPES AND INSTALL INLET PROTECTION SILT BARRIERS AT ENDS OF EXPOSED PIPES.
 8. CONSTRUCT ALL GRATE INLETS AND DRAINAGE STRUCTURES. INLET PROTECTION SILT BARRIERS MAY BE REMOVED TEMPORARILY FOR THIS CONSTRUCTION.
 9. REMOVE SILT BARRIERS AROUND INLETS AND MAN-HOLES NO MORE THAN 48 HOURS PRIOR TO PLACING STABILIZED BASE COURSE.
 10. INSTALL BASE MATERIAL AS REQUIRED FOR PAVEMENT, CURB & GUTTER.
 11. COMPLETE PLANTING AND/OR SEEDING OF VEGETATED AREAS TO ACCOMPLISH STABILIZATION, IN ACCORDANCE WITH TURF RE-ESTABLISHMENT NOTES, SHEET L4 00.
 12. REMOVE TEMPORARY CONSTRUCTION ACCESS AND SILT BARRIERS.

- EROSION CONTROL MAINTENANCE NOTES**
1. ALL MEASURES STATED ON THIS EROSION AND SEDIMENT CONTROL PLAN, AND IN THE STORM WATER POLLUTION PREVENTION PLAN, SHALL BE MAINTAINED IN FULLY FUNCTIONAL CONDITION UNTIL NO LONGER REQUIRED FOR A COMPLETED PHASE OF WORK OR FINAL STABILIZATION OF THE SITE. ALL EROSION AND SEDIMENTATION CONTROL MEASURES SHALL BE CHECKED BY A QUALIFIED PERSON ON A SCHEDULE WHICH COMPLIES WITH THE GENERAL PERMIT REQUIREMENTS AND CLEANED AND REPAIRED WITHIN 48 HOURS OF THE INSPECTION IN ACCORDANCE WITH THE FOLLOWING:
 - 1.A. INLET PROTECTION DEVICES AND BARRIERS SHALL BE REPAIRED OR REPLACED IF THEY SHOW SIGNS OF UNDERMINING, OR DETERIORATION.
 - 1.B. ALL SEEDED AREAS SHALL BE CHECKED REGULARLY TO SEE THAT A GOOD STAND IS MAINTAINED. AREAS SHOULD BE FERTILIZED, WATERED AND RESEEDED AS NEEDED.
 - 1.C. SILT BARRIERS SHALL BE REPAIRED TO THEIR ORIGINAL CONDITIONS IF DAMAGED. SEDIMENT SHALL BE REMOVED FROM THE SILT BARRIERS WHEN IT REACHES ONE-HALF THE HEIGHT OF THE SILT BARRIERS. THE TEMPORARY PARKING AND STORAGE AREA (IF PRESENT) SHALL BE KEPT IN GOOD CONDITION (SUITABLE FOR PARKING AND STORAGE). THIS MAY REQUIRE PERIODIC TOP DRESSING OF THE TEMPORARY PARKING AS CONDITIONS DEMAND.
 - 1.D. OUTLET STRUCTURES IN THE SEDIMENTATION BASINS OR SEDIMENT TRAPS (IF PRESENT) SHALL BE MAINTAINED IN OPERATIONAL CONDITION AT ALL TIMES. SEDIMENT SHALL BE REMOVED FROM SEDIMENT BASINS OR TRAPS WHEN THE DESIGN CAPACITY HAS BEEN REDUCED BY 50%.
 - 1.E. MAINTENANCE PROCEDURES FOR THE EROSION AND SEDIMENTATION CONTROL SYSTEMS SPECIFIED IN THE STORM WATER POLLUTION PREVENTION PLAN.

NOTES FOR CHANGES TO SWPPP

THE TXR15000 GENERAL PERMIT REQUIRES THAT THE PERMITTEE REVISION OR UPDATE THIS SWPPP WHENEVER THERE IS A CHANGE IN DESIGN, CONSTRUCTION, OPERATION, OR MAINTENANCE, OR WHENEVER THE RESULT OF AN INSPECTION INDICATES THAT THIS SWPPP IS INEFFECTIVE IN ELIMINATING OR SIGNIFICANTLY MINIMIZING POLLUTANTS IN STORMWATER DISCHARGES. HOWEVER, THE REGULATIONS OF THE TEXAS BOARD OF PROFESSIONAL ENGINEERS REQUIRE THAT CHANGES MADE BY THE CONTRACTOR DURING CONSTRUCTION MUST BE AUTHORIZED BY A LICENSED TEXAS ENGINEER. THESE CHANGES MAY BE AUTHORIZED BY THE ENGINEER OF RECORD THROUGH UPDATED DRAWINGS, WORK ORDER CHANGES, OR OTHER METHODS ACCEPTABLE TO THE ENGINEER; OR BY ANOTHER ENGINEER PROVIDED THAT THEY NOTIFY THE ENGINEER OF RECORD.

**** NOTICE TO CONTRACTORS - TOPOGRAPHIC SURVEY ****

TOPOGRAPHIC INFORMATION TAKEN FROM A TOPOGRAPHIC SURVEY PERFORMED BY WINDROSE LAND SERVICES, LLC. CONTRACTOR SHALL NOTIFY THE ENGINEER IMMEDIATELY, IN WRITING, OF ANY DISCREPANCIES OR OMISSIONS TO THE TOPOGRAPHIC INFORMATION. THE CONTRACTOR(S) SHALL BE RESPONSIBLE FOR CONFIRMING THE LOCATION (HORIZONTAL/VERTICAL) OF ANY BURIED CABLES, CONDUITS, PIPES, AND STRUCTURES (STORM SEWER, SANITARY SEWER, WATER, GAS, TELEVISION, TELEPHONE, ETC.) WHICH IMPACT THE CONSTRUCTION SITE. THE CONTRACTOR(S) SHALL NOTIFY THE OWNER AND ENGINEER IF ANY DISCREPANCIES ARE FOUND BETWEEN THE ACTUAL CONDITIONS VERSUS THE DATA CONTAINED IN THE CONSTRUCTION PLANS. ANY COSTS INCURRED AS THE RESULT OF NOT CONFIRMING THE ACTUAL LOCATION (HORIZONTAL/VERTICAL) OF SAID CABLES, CONDUITS, PIPES, AND STRUCTURES SHALL BE BORNE BY THE CONTRACTOR. ADDITIONALLY, THE CONTRACTOR(S) SHALL NOTIFY THE OWNER AND ENGINEER IF ANY ERRORS OR DISCREPANCIES ARE FOUND ON THE CONSTRUCTION DOCUMENTS (PS&E), WHICH NEGATIVELY IMPACT THE PROJECT. THE ENGINEER AND OWNER SHALL BE INDEMNIFIED OF PROBLEMS AND/OR COST WHICH MAY RESULT FROM CONTRACTOR'S FAILURE TO NOTIFY ENGINEER AND OWNER.

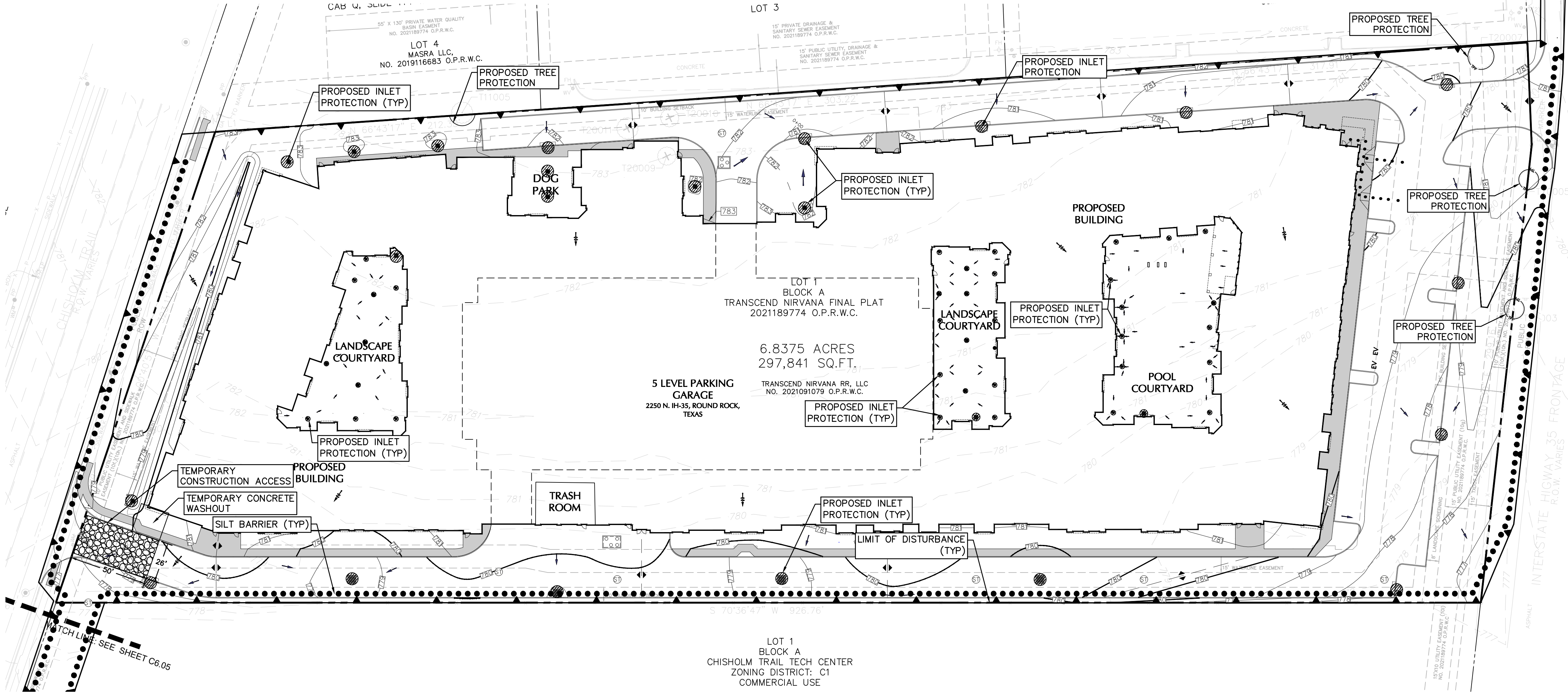

- EROSION CONTROL NOTES**
1. CONTRACTOR MUST COMPLETE A CONSTRUCTION SITE NOTICE, OBTAIN SIGNED COPIES OF NOI FORM FOR BOTH OWNER AND CONTRACTOR (IF APPLICABLE TO THIS SITE), AND POST THEM AT THE CONSTRUCTION SITE, IN ACCORDANCE WITH THE NATIONAL POLLUTANT DISCHARGE ELIMINATION SYSTEM (NPDES) GENERAL PERMIT FOR CONSTRUCTION ACTIVITIES (TXR15000). THE GENERAL CONTRACTOR, (AND ALL SUBCONTRACTORS INVOLVED WITH ANY CONSTRUCTION ACTIVITY RELATED TO EARTHWORK, EROSION CONTROL, ETC., OR WHICH UTILIZE POSSIBLE POLLUTANTS AS DEFINED IN THE TPDES GENERAL PERMIT) MUST BE FAMILIAR WITH THE CONTENTS OF THE STORM WATER POLLUTION PREVENTION PLAN (SWPPP) AS WELL AS ALL THE REQUIREMENTS SET FORTH IN THE TPDES GENERAL PERMIT AND ANY APPLICABLE LOCAL PERMIT REQUIREMENTS, AND SHALL COMPLY WITH ALL SUCH REQUIREMENTS DURING ALL CONSTRUCTION ACTIVITIES.
 2. THE CONTRACTOR SHALL ADHERE TO THE SEQUENCE OF OPERATIONS FOR EROSION CONTROL IMPLEMENTATION SHOWN HEREON. ANY DEVIATION FROM THIS SEQUENCE DEEMED NECESSARY BY THE CONTRACTOR MAY REQUIRE THAT THE STORMWATER POLLUTION PREVENTION PLAN BE MODIFIED IN ACCORDANCE WITH THE NPDES GENERAL PERMIT GUIDELINES.
 3. THE CONTRACTOR SHALL MODIFY THIS PLAN TO SHOW LOCATIONS OF TEMPORARY WASHDOWN AREAS, PORTABLE TOILETS, EQUIPMENT MAINTENANCE/REPAIR AREAS, STOCKPILE AREAS, FUEL STORAGE AREAS, CONCRETE WASH-OUT PITS, AND POLLUTANT CONTROLS FOR EACH, AS SOON AS POSSIBLE. THE GENERAL PERMIT AUTHORIZES THE LAND DISPOSAL OF WASH-OUT WATER FROM CONCRETE TRUCKS THAT ARE ASSOCIATED WITH OFF-SITE PRODUCTION FACILITIES, AS LONG AS THE DISCHARGE IS INTO SPECIFICALLY DESIGNATED DIKED AREAS WHICH HAVE BEEN PREPARED TO PREVENT CONTACT BETWEEN THE CONCRETE AND/OR WASH-OUT WATER AND STORMWATER WHICH WILL BE DISCHARGED FROM THE SITE, TO PREVENT DIRECT DISCHARGE TO SURFACE WATERS (SEE CONCRETE WASH-OUT DETAIL SHOWN IN PLANS). DIRECT DISCHARGE OF CONCRETE TRUCK WASH-OUT WATER TO SURFACE WATERS IN THE STATE, INCLUDING DISCHARGE TO STORM SEWERS, IS PROHIBITED BY THE GENERAL PERMIT. IF A CONCRETE PLANT IS LOCATED AT CONSTRUCTION SITE, CONTRACTOR SHALL OBTAIN COVERAGE UNDER AND COMPLY WITH GENERAL PERMIT TXG110000 OR INDIVIDUAL PERMIT.
 4. THE GENERAL CONTRACTOR SHALL PERFORM ALL REQUIRED INSPECTIONS OF STORMWATER CONTROLS AND PRACTICES AT FREQUENCIES GIVEN IN THE NPDES GENERAL PERMIT, AND SHALL COMPLETE AND SIGN APPROPRIATE INSPECTION FORMS.
 5. OIL AND GREASE ABSORBING MATERIALS SHALL BE READILY AVAILABLE ON-SITE AND SHALL BE PROMPTLY USED TO CONTAIN AND/OR CLEAN UP ALL FUEL OR CHEMICAL SPILLS OR LEAKS.
 6. DUST CONTROL SHALL BE ACCOMPLISHED BY WATERING DRY, EXPOSED AREAS ON A REGULAR BASIS. SPRAYING OF PETROLEUM BASED OR TOXIC LIQUIDS FOR THIS PURPOSE IS PROHIBITED.
 7. DISTURBED AREAS OF THE SITE WHERE CONSTRUCTION ACTIVITIES HAVE CEASED FOR AT LEAST FOURTEEN DAYS SHALL BE TEMPORARILY STABILIZED WITH VEGETATION AND MULCH.
 8. DISTURBED AREAS OF THE SITE WHERE CONSTRUCTION ACTIVITIES HAVE PERMANENTLY CEASED SHALL BE PERMANENTLY SEEDED WITHIN FOURTEEN DAYS PER SEEDING OR LANDSCAPING SPECIFICATIONS.
 9. ALL VEHICLES SHALL BE CLEANED AT THE CONSTRUCTION EXIT POINTS ACCORDING TO NOTES SHOWN ON THE DETAIL THEREOF. IF THE MAJORITY OF MUD OR DIRT IS NOT REMOVED FROM EXITING TRAFFIC, HOSE BIBS SHALL BE PROVIDED AT CONSTRUCTION TRAFFIC EXIT POINTS, AND VEHICLE TIRRES SHALL BE WASHED BEFORE EXITING ONTO PUBLIC ROADS. SILT FROM THIS WASHING OPERATION SHALL BE INTERCEPTED AND TRAPPED BEFORE WASHWATER IS ALLOWED TO BE DISCHARGED OFF-SITE.
 10. ALL MATERIALS SPILLED, DROPPED, WASHED OR TRACKED ONTO ADJACENT ROADWAYS BY VEHICLES EXITING THE SITE SHALL BE CLEANED OR REMOVED IMMEDIATELY.
 11. CONTRACTOR SHALL PREVENT ANY SILTATION FROM ENTERING THE STORM SEWER SYSTEM. ALL INLETS AND INLET OPENINGS SHALL BE FULLY ENCLOSED WITH APPROPRIATE INLET PROTECTION DEVICES.
 12. THE CONTRACTOR SHALL REMOVE ALL ACCUMULATED SILT IN ANY TEMPORARY OR PERMANENT DETENTION PONDS, STORM SEWER INLETS AND PIPES, AND ALONG SILT BARRIERS, WITHIN 48 HOURS AFTER INSPECTION OF DEVICES REVEALS THE PRESENCE OF EXCESSIVE SILTATION.
 13. SILT BARRIERS SHALL BE PLACED AROUND ANY STOCKPILES USED ON THIS SITE.
 14. THE CONTRACTOR IS ADVISED TO CONSTRUCT TEMPORARY OR PERMANENT FENCING AROUND DETENTION PONDS AND SEDIMENT BASINS AT THE EARLIEST POSSIBLE TIME TO PREVENT ACCIDENTAL ACCESS BY PERSONS OR ANIMALS.
 15. ANY ADDITIONAL EROSION CONTROL MEASURES REQUIRED TO ENSURE COMPLIANCE WITH THE TPDES GENERAL PERMIT OR LOCAL PERMIT REQUIREMENTS SHALL BE IMPLEMENTED BY THE CONTRACTOR, AT NO ADDITIONAL EXPENSE TO THE OWNER.
 16. ALL TEMPORARY EROSION CONTROL MEASURES SHALL BE REMOVED AND PROPERLY DISPOSED OF OFF-SITE WITHIN THIRTY DAYS AFTER STABILIZATION OF ALL SURFACES.
 17. THE CONTRACTOR SHALL ASSUME LIABILITY FOR DAMAGE TO ADJACENT PROPERTIES AND/OR PUBLIC RIGHT-OF-WAY RESULTING FROM FAILURE TO FULLY IMPLEMENT AND EXECUTE ALL EROSION CONTROL PROCEDURES SHOWN AND NOTED IN THESE PLANS.
 18. WHENEVER DIRT, ROCK, OR OTHER MATERIALS ARE IMPORTED OR EXPORTED ON THE PRIMARY CONSTRUCTION SITE, CONTRACTOR SHALL ASSUME RESPONSIBILITY FOR COMPLIANCE WITH ALL TCEQ STORMWATER REQUIREMENTS FOR THE REMOTE SITE. CONTRACTOR SHALL FURNISH THE ENGINEER AND THE OWNER'S CONSTRUCTION MANAGER WITH DOCUMENTATION OF COVERAGE FOR THE BORROW OR FILL SITE UNDER A NPDES PERMIT FOR STORMWATER DISCHARGES AND OF A WRITTEN AGREEMENT WITH THE LANDOWNER OF THE REMOTE SITE INDICATING EROSION CONTROL MEASURES HAVE BEEN IMPLEMENTED THEREON. AT A MINIMUM, EROSION CONTROL MEASURES MUST CONSIST OF PERIMETER CONTROLS (SILT BARRIERS) ON ALL DOWN SLOPES AND SIDE SLOPE BOUNDARIES OF ANY DISTURBED AREA, PLUS PROVISIONS FOR RE-VEGETATION AFTER THE FILL MATERIALS ARE IN PLACE.
 19. ALL SLOPES ON SITE WHICH ARE 3:1 OR STEEPER SHALL BE STABILIZED BY TRACK WALKING (TRAVELING UP AND DOWN THE SLOPE WITH A TRACKED VEHICLE) FOLLOWED BY INSTALLATION OF EROSION CONTROL BLANKET INSTALLED IN ACCORDANCE WITH MANUFACTURER'S INSTRUCTIONS. EROSION CONTROL BLANKET SHALL BE NORTH AMERICAN GREEN S150 OR APPROVED EQUAL.



THESE PLANS ARE SUBJECT TO REVIEW & APPROVAL BY JURISDICTIONAL ENTITIES.



LANGAN
 Langan Engineering and Environmental Services, Inc.
 9606 N. Mopac Expressway, Suite 110
 Austin, TX 78759
 T: 737.289.7800 F: 737.289.7801 www.langan.com
 TBPE FIRM REG. #F-13709

CoRR Tracking Number : SDP23-00054

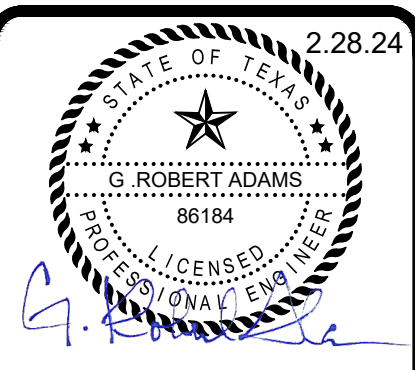

REVISIONS

NO.	DESCRIPTION

JADE AT CHISHOLM TRAIL
 392 APARTMENT UNITS IN ROUND ROCK, TEXAS
 GLENRIDGE DEVELOPMENT

PERMIT SET
 ISSUED 02-28-2024

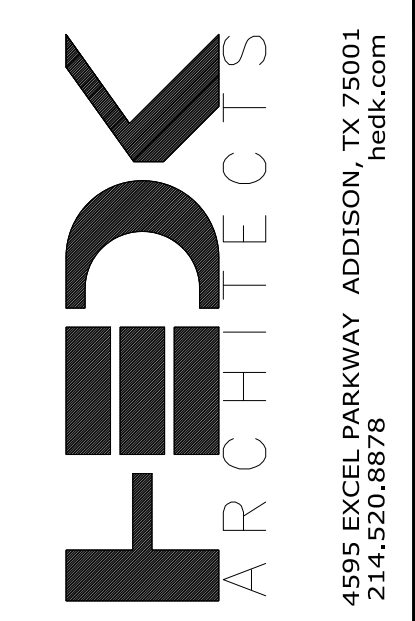

DATE: 02-28-2024
 PROJECT: 22137
 SHEET NUMBER: C2.00
 EROSION & SEDIMENT CONTROL

****NOTICE TO CONTRACTORS - UTILITIES****

THE CONTRACTOR IS SPECIFICALLY CAUTIONED THAT THE LOCATION AND/OR ELEVATION OF ANY EXISTING UTILITIES AS SHOWN ON THESE PLANS ARE BASED ON RECORDS OF THE VARIOUS UTILITY COMPANIES, THE GOVERNING MUNICIPALITY, AND WHERE POSSIBLE, MEASUREMENTS TAKEN IN THE FIELD. THE INFORMATION PROVIDED IS NOT TO BE RELIED ON AS BEING EXACT OR COMPLETE. THE CONTRACTOR MUST CALL THE APPROPRIATE UTILITY COMPANY AT LEAST 48 HOURS BEFORE ANY EXCAVATION TO REQUEST EXACT FIELD LOCATION OF UTILITIES. IT SHALL BE THE RESPONSIBILITY OF THE CONTRACTOR TO RELOCATE ALL EXISTING UTILITIES WHICH CONFLICT WITH THE PROPOSED IMPROVEMENTS SHOWN ON THESE PLANS.

**** NOTICE TO CONTRACTORS - TOPOGRAPHIC SURVEY ****

TOPOGRAPHIC INFORMATION TAKEN FROM A TOPOGRAPHIC SURVEY PERFORMED BY WINDROSE LAND SERVICES, LLC. CONTRACTOR SHALL NOTIFY THE ENGINEER IMMEDIATELY, IN WRITING, OF ANY DISCREPANCIES OR OMISSIONS TO THE TOPOGRAPHIC INFORMATION. THE CONTRACTOR(S) SHALL BE RESPONSIBLE FOR CONFIRMING THE LOCATION (HORIZONTAL/VERTICAL) OF ANY BURIED CABLES, CONDUITS, PIPES, AND STRUCTURES (STORM SEWER, SANITARY SEWER, WATER, GAS, TELEVISION, TELEPHONE, ETC.) WHICH IMPACT THE CONSTRUCTION SITE. THE CONTRACTOR(S) SHALL NOTIFY THE OWNER AND ENGINEER IF ANY DISCREPANCIES ARE FOUND BETWEEN THE ACTUAL CONDITIONS VERSUS THE DATA CONTAINED IN THE CONSTRUCTION PLANS. ANY COSTS INCURRED AS THE RESULT OF NOT CONFIRMING THE ACTUAL LOCATION (HORIZONTAL/VERTICAL) OF SAID CABLES, CONDUITS, PIPES, AND STRUCTURES SHALL BE BORNE BY THE CONTRACTOR. ADDITIONALLY, THE CONTRACTOR(S) SHALL NOTIFY THE OWNER AND ENGINEER IF ANY ERRORS OR DISCREPANCIES ARE FOUND ON THE CONSTRUCTION DOCUMENTS (PS&E), WHICH NEGATIVELY IMPACT THE PROJECT. THE ENGINEER AND OWNER SHALL BE INDEMNIFIED OF PROBLEMS AND/OR COST WHICH MAY RESULT FROM CONTRACTOR'S FAILURE TO NOTIFY ENGINEER AND OWNER.



Know what's below.
Call before you dig.

THESE PLANS ARE SUBJECT TO REVIEW & APPROVAL BY JURISDICTIONAL ENTITIES.

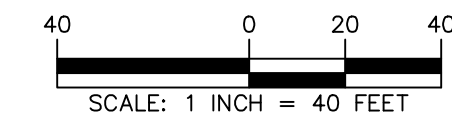
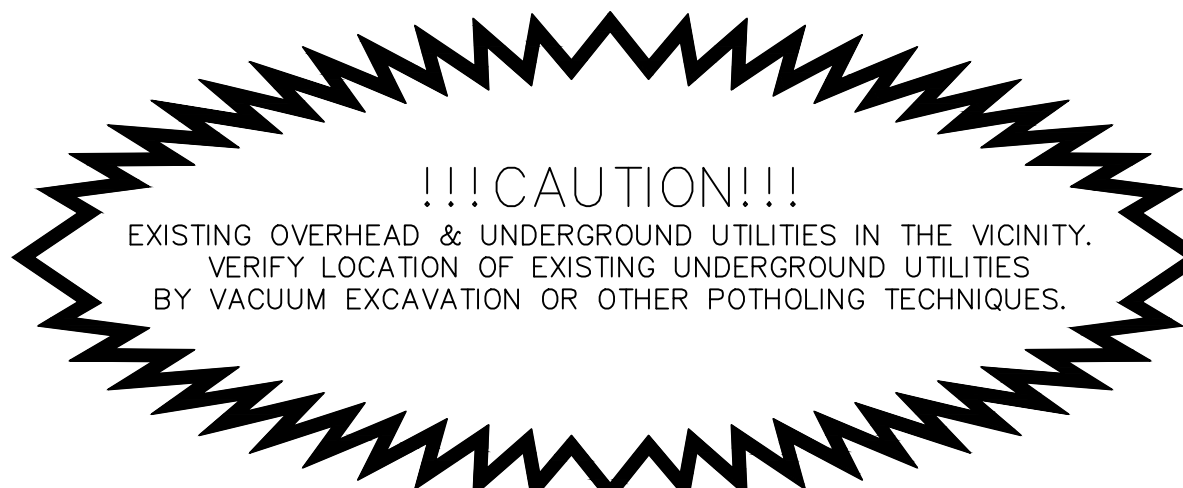

LEGEND	
PROPERTY LINE	---
EXISTING CONTOUR	1000
PROPOSED CONTOUR	1000
PROPOSED GRATE INLET	☐
PROPOSED FLOW ARROW	→
SPOT ELEVATION	TP=996.38
FLOW LINE	→
GRADE BREAK LINE	--- ---
ACCESSIBLE ROUTE	---
FG	FINISH GRADE
TI	TOP OF INLET
TP	TOP OF PAVEMENT
TC	TOP OF CURB
BC	BOTTOM OF CURB
ME	MATCH EXISTING GRADE

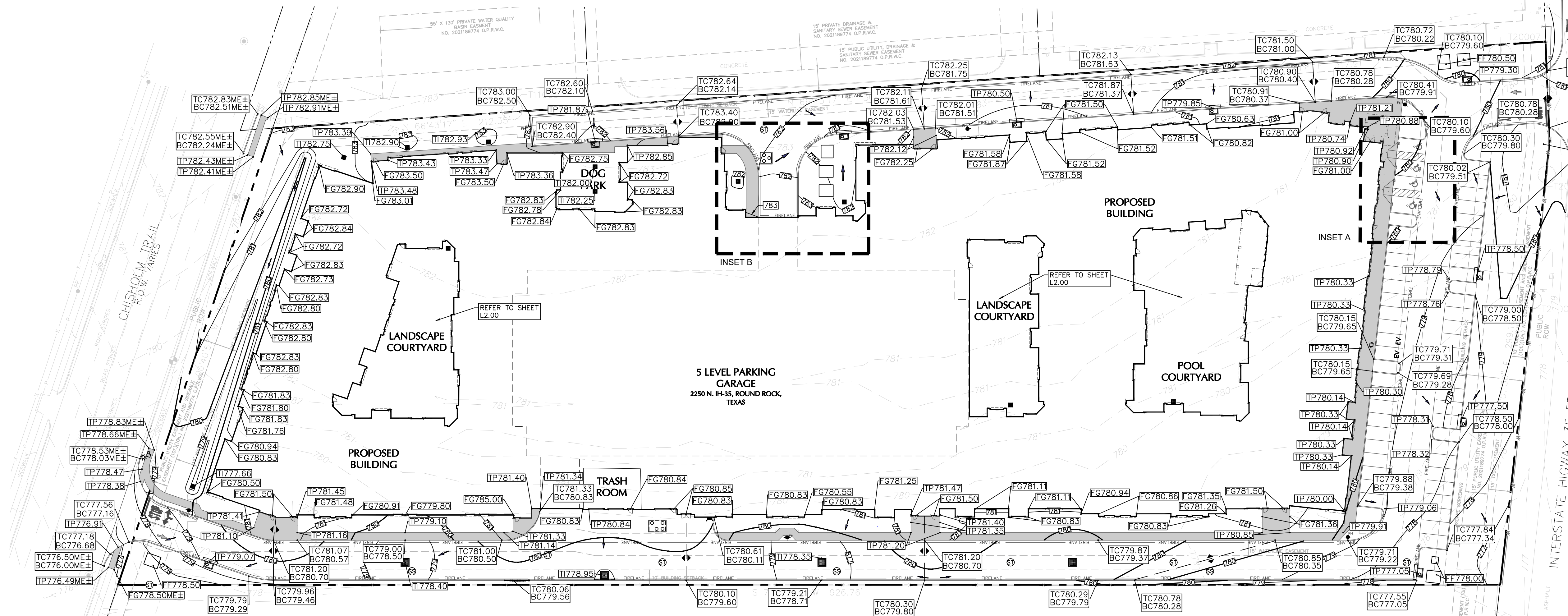

OVERALL GRADING PLAN

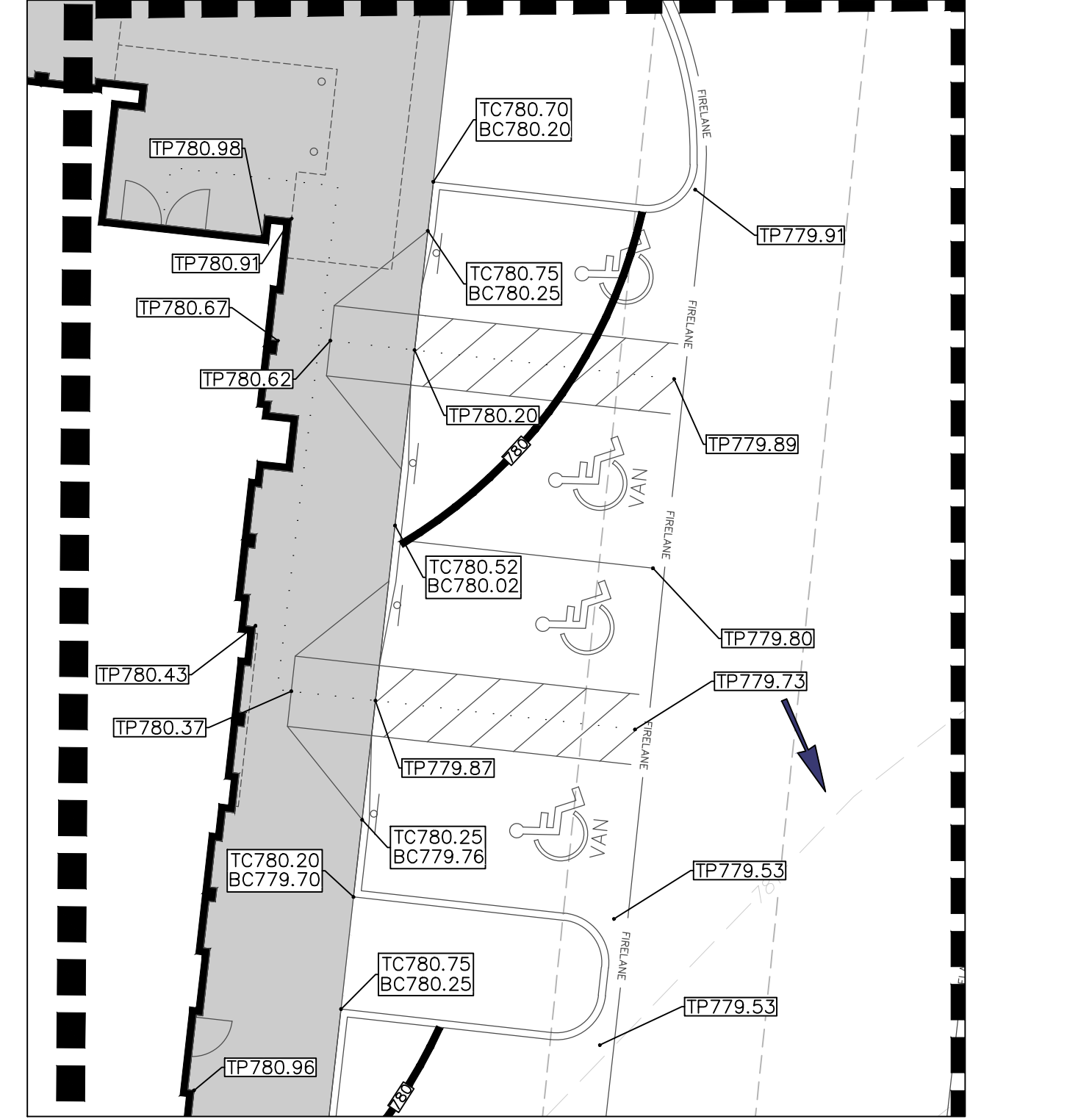

INSET A: ADA PARKING GRADING PLAN

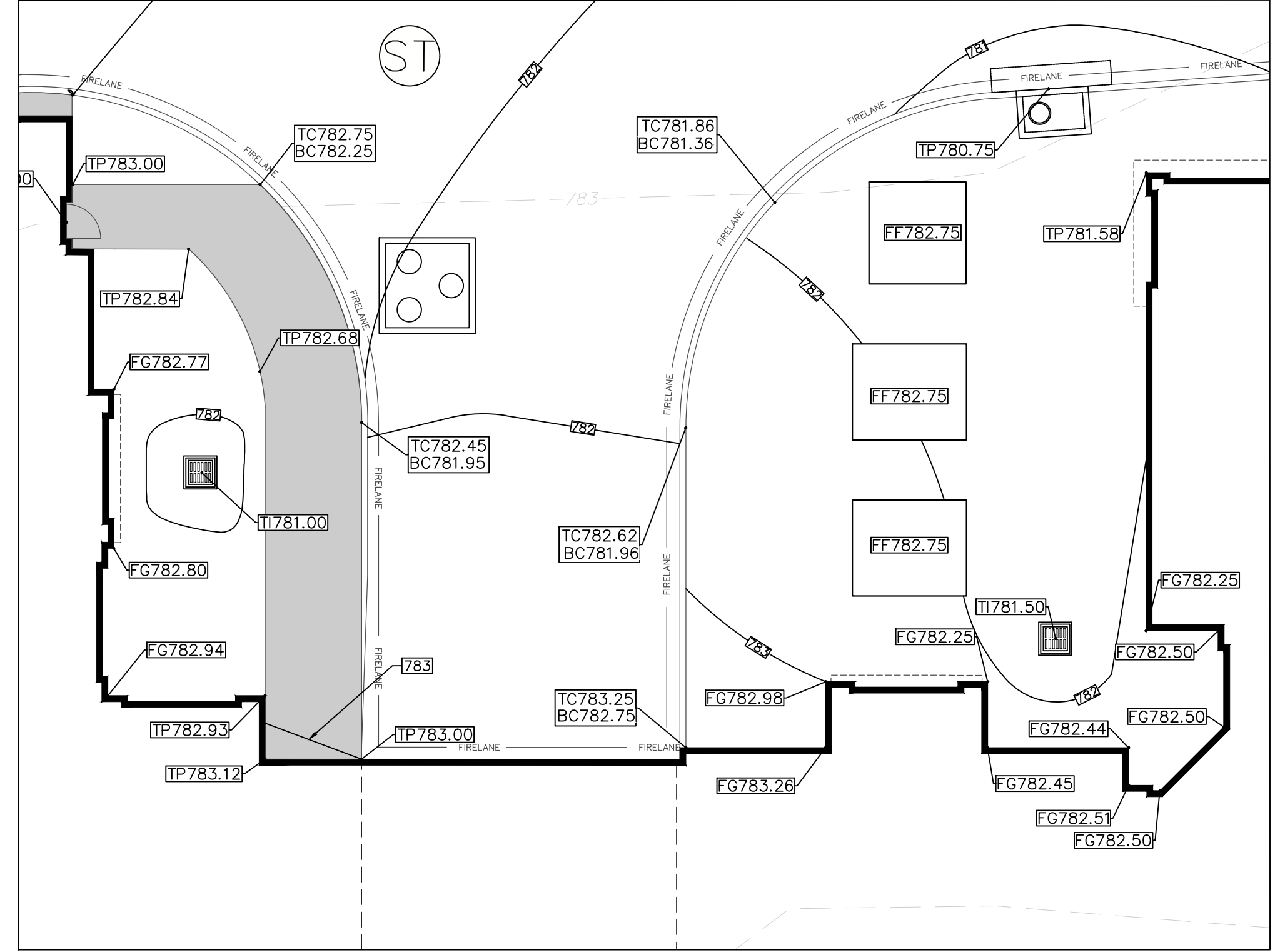

INSET B: NORTH GARAGE ENTRANCE GRADING PLAN

STANDARD ACCESSIBILITY REQUIREMENTS	
PARKING:	
(A)	ACCESSIBLE PARKING SPACES SHALL BE AS NOTED TO A MIN. 96" WIDE OR A MIN. 132" WIDE FOR VAN DESIGNATED SPACES WITH A MAXIMUM SLOPE OF 2% (IN ALL DIRECTIONS). ALL BUILDINGS SHALL CONTAIN AT LEAST ONE VAN ACCESSIBLE SPACE FOR NO LESS THAN ONE VAN SPACE FOR EVERY 6 ACCESSIBLE SPACES.
(B)	EACH ACCESSIBLE PARKING SPACE SHALL HAVE A VERTICALLY MOUNTED (OR SUSPENDED) SIGN SHOWING THE SYMBOL OF ACCESSIBILITY. APPROPRIATE VAN ACCESSIBLE SPACES MUST INCORPORATE "VAN-ACCESSIBLE" BELOW THE SYMBOL OF ACCESSIBILITY. SIGNS SHALL BE LOCATED AS NOTED TO 80" (MIN.) ABOVE THE ADJACENT PAVED SURFACE TO BOTTOM OF SIGN.
(C)	ALL ACCESS AISLES SERVING ACCESSIBLE PARKING SPACES SHALL BE AS NOTED TO A 60" WIDE MINIMUM.
RAMPS:	
(D)	RAMPS EXCEEDING 6" IN RISE (EXCLUDING CURB RAMPS) SHALL HAVE APPROPRIATE EDGE PROTECTION WITH HANDRAILS ON EACH SIDE AT BETWEEN 34" AND 38", AND EXTEND 12" BEYOND THE TOP AND BOTTOM OF RAMP. HANDRAIL SHALL NOT DIMINISH THE CLEAR AREA REQUIRED FOR TOP AND BOTTOM LANDINGS SERVING THE RAMPS.
(E)	RAMPS SHALL HAVE A SURFACE ARRANGED SO THAT WATER WILL NOT ACCUMULATE. COLOR OF RAMP FINISH MATERIAL (INCLUDING CONCRETE) SHALL HAVE A LIGHT AND REFLECTIVE VALUE TO SIGNIFICANTLY CONTRAST FROM ADJACENT SURFACES OR COLORS ONLY IF REQUIRED BY LOCAL OR STATE JURISDICTION.
(F)	LANDINGS FOR RAMPS SHALL BE AS WIDE AS THE RAMP AND 60" LONG MINIMUM (36" MINIMUM FOR CURB RAMPS)
(G)	RAMPS SHALL NOT EXCEED A 1:12 RUNNING SLOPE OR 30° RISE
(H)	RAMPS AND LANDINGS SHALL NOT EXCEED 1:48 (2% CROSS SLOPE)
SIDEWALKS AND ACCESSIBLE ROUTES:	
(I)	SIDEWALKS (ACCESSIBLE ROUTES) MUST BE AT LEAST 36" WIDE WITH 5'X5' CLEAR PASSING OPPORTUNITIES IN INCREMENTS LESS THAN 150 LF SIDEWALK. CROSS SLOPE SHALL NOT EXCEED 1:48 (2%)
(J)	LONGITUDINAL SLOPE OF ANY SIDEWALK (ACCESSIBLE ROUTE) SHALL NOT EXCEED 1:20 (5%)

GENERAL SITE GRADING NOTE

- AS PART OF THE BASE BID THE CONTRACTOR SHALL PROVIDE/IMPORT ALL SELECT FILL AND TOPSOIL MATERIAL NECESSARY TO ACHIEVE FINAL GRADE PER PLAN.
- ALL AREAS WITHIN CONSTRUCTION LIMITS NOT COVERED WITH AN IMPERVIOUS MATERIAL SHALL BE COVERED WITH TOPSOIL. THE TOPSOIL SHALL BE IN CONFORMANCE WITH THE TOPSOIL NOTES LISTED IN THE PLAN SET AND SPECIFICATIONS FOR THIS PROJECT.
- BASE BID SHALL ALSO INCLUDE HAUL OFF OF EXCESS MATERIAL AS NECESSARY.
- ANY FILL PLACED ONSITE SHALL BE TESTED AND APPROVED BY THE PROJECT GEOTECHNICAL ENGINEER AND BE IN CONFORMANCE WITH RECOMMENDATIONS LISTED IN THE SITE GEOTECHNICAL REPORT NO. AA022-138-00 DATED 12/08/2022 BY RABA KISTNER CONSULTANTS INC. OR ANY SUPPLEMENTAL ADDENDUMS TO BOTH REPORTS.

SITE GRADING - IBC REQUIREMENT (SEC. 1804)

- THE GROUND IMMEDIATELY ADJACENT TO THE FOUNDATION SHALL BE SLOPED AWAY FROM THE BUILDING AT A SLOPE OF NOT LESS THAN ONE UNIT VERTICAL IN 20 UNITS HORIZONTAL (5-PERCENT SLOPE) FOR A MINIMUM DISTANCE OF 10-FEET MEASURED PERPENDICULAR TO THE FACE OF THE WALL.
- IF PHYSICAL OBSTRUCTIONS OR LOT LINES PROHIBIT 10-FOET OF HORIZONTAL DISTANCE, A 5-PERCENT SLOPE SHALL BE PROVIDED TO AN APPROVED ALTERNATIVE METHOD OF DIVERTING WATER AWAY FROM THE FOUNDATION. SWALES USED FOR THIS PURPOSE SHALL BE SLOPED A MINIMUM OF 2 PERCENT WHERE LOCATED WITHIN 10-FOET OF THE BUILDING FOUNDATION.
- IMPERVIOUS SURFACES WITHIN 10-FOET OF THE BUILDING FOUNDATION SHALL BE SLOPED A MINIMUM OF 2-PERCENT AWAY FROM THE BUILDING.

NOTE TO BUILDING OFFICIAL

ACCESSIBLE PATHS ADJACENT TO THE BUILDING HAVE BEEN DESIGNED LESS THAN 2% AWAY FROM BUILDING FOUNDATIONS TO ALLOW FOR CONSTRUCTION TOLERANCES WHILE MAINTAINING COMPLIANCE WITH ADA REQUIREMENTS. WE ACKNOWLEDGE THE AUTHORITY AND DISCRETION OF THE BUILDING OFFICIAL TO APPLY MINIMUM SLOPE REQUIREMENTS OF IBC-1804. APPROVAL OF THIS PLAN WILL BE CONSIDERED AS ACCEPTANCE THAT THE INTENT OF THE IBC-1804 REQUIREMENT HAS BEEN MET.

LANGAN
Langan Engineering and Environmental Services, Inc.
9606 N. Mopac Expressway, Suite 110
Austin, TX 78759
T: 737.289.7800 F: 737.289.7801 www.langan.com
TBPE FIRM REG. #F-13709

CoRR Tracking Number : SDP23-00054

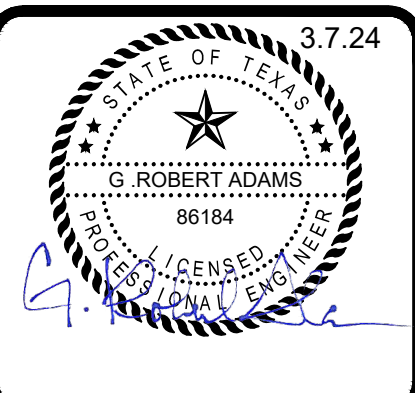

REVISIONS

NO.	DATE	DESCRIPTION

JADE AT CHISHOLM TRAIL
392 APARTMENT UNITS IN ROUND ROCK, TEXAS
GLENRIDGE DEVELOPMENT

PERMIT SET
ISSUED 02-28-2024

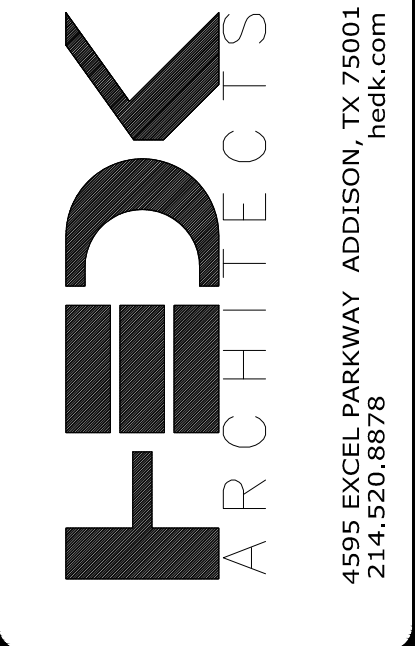

DATE
02-28-2024

PROJECT
22137

SHEET NUMBER
C5.00

GRADING PLAN

COPYRIGHT © HEDK Architects ALL RIGHTS RESERVED

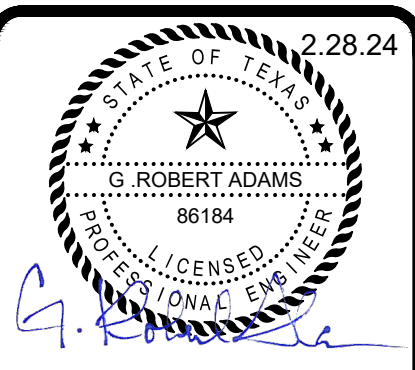

REVISIONS

NO.	DATE	DESCRIPTION

JADE AT CHISHOLM TRAIL
 392 APARTMENT UNITS IN ROUND ROCK, TEXAS
 GLENRIDGE DEVELOPMENT

PERMIT SET
 ISSUED 02-28-2024

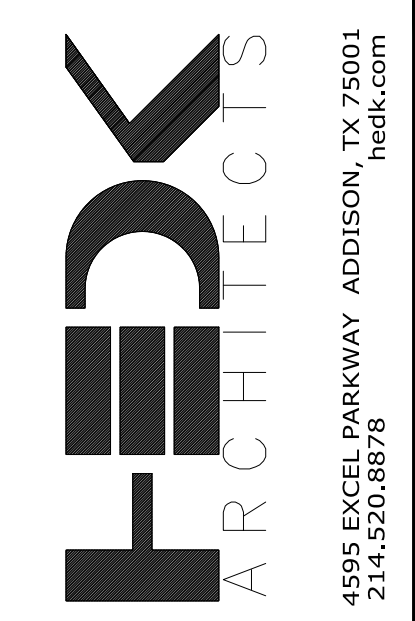

DATE
02-28-2024

PROJECT
22137

SHEET NUMBER
C6.00
EXISTING DRAINAGE AREA MAP

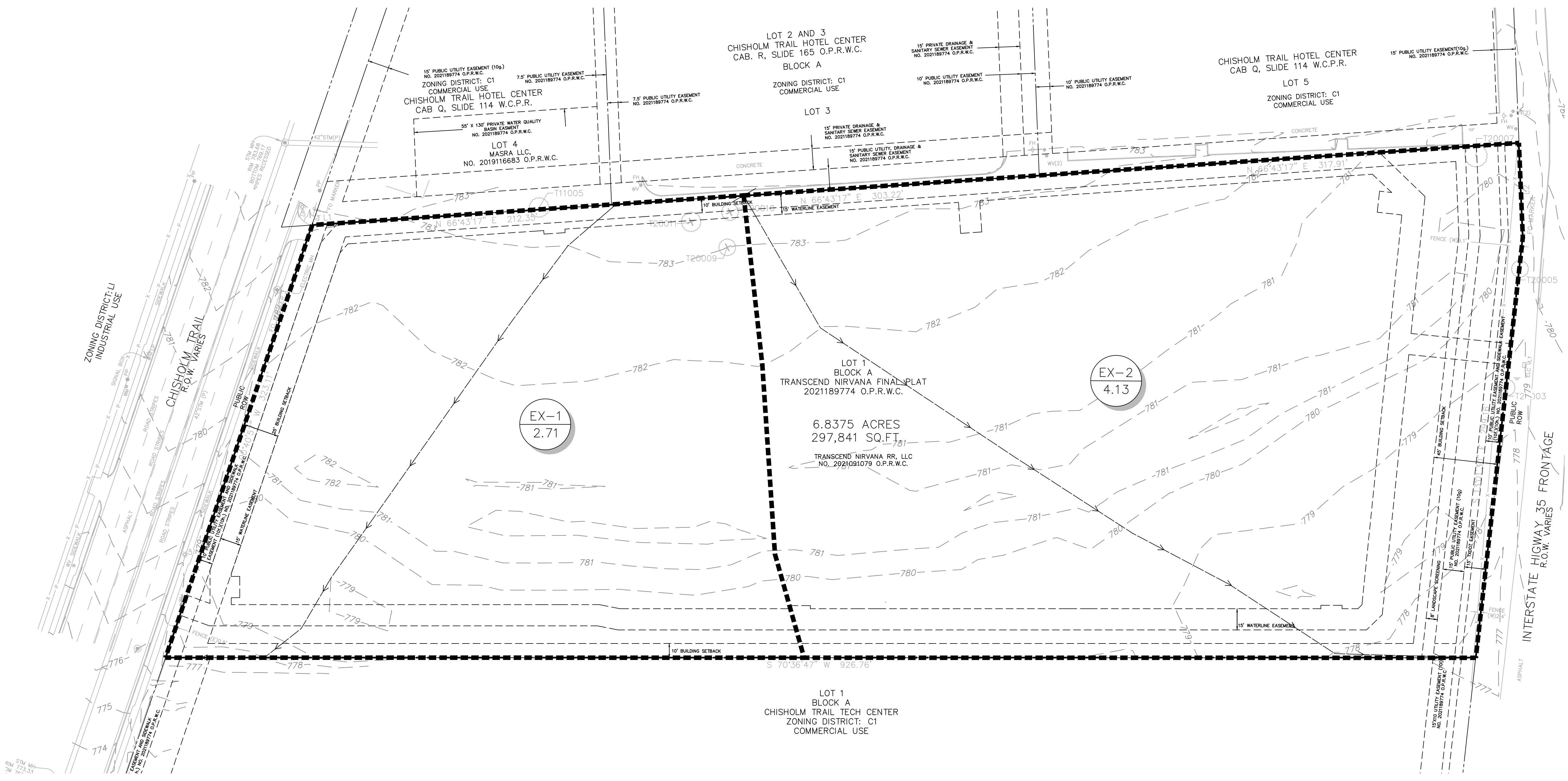
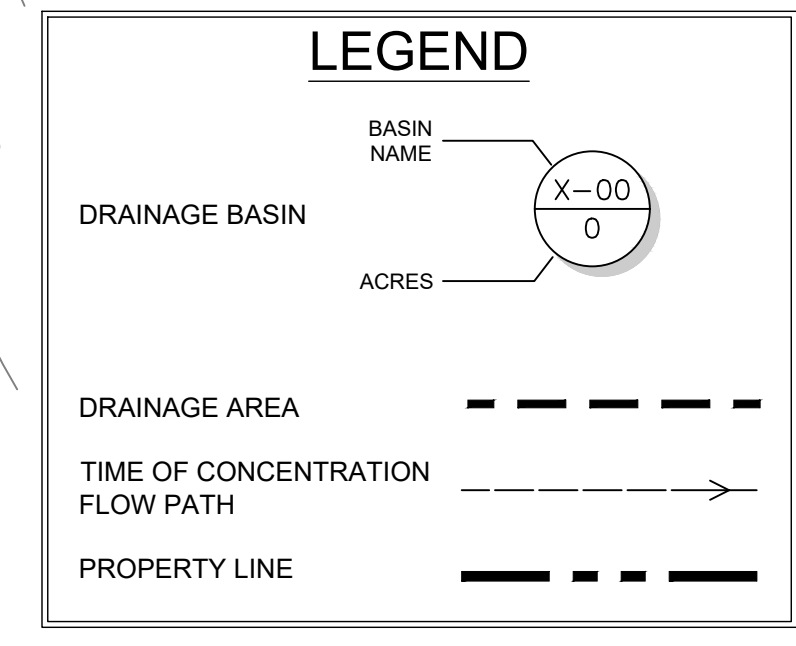
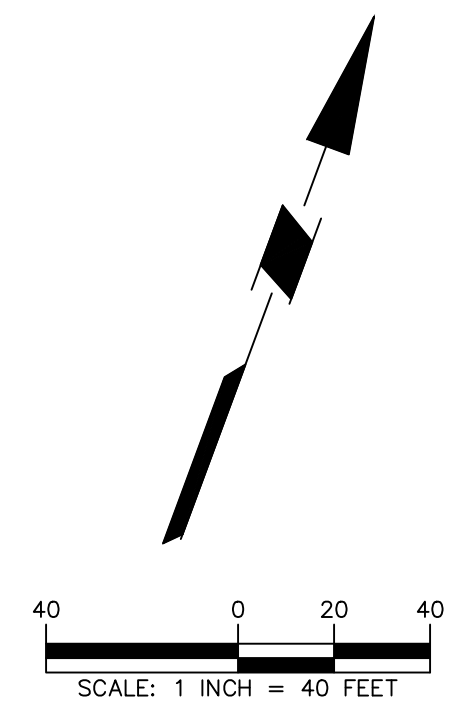

TIME OF CONCENTRATION CALCULATIONS														
Drainage Area Designation	Sheet Flow					Shallow Concentrated Flow					Channel Flow			Total
	Manning's (n)	Length (L)	Slope (s)	2-Yr, 24-hr rainfall	Time (T _s)	Length (L)	Slope (s)	Cover Type	Velocity	Time (T _c)	Length (L)	Velocity	Time (T _c)	Time (T _c)
	(ft)	(ft/ft)	(in)	(min)	(ft)	(ft/ft)	-	(ft/sec)	(min)	(ft)	(ft/sec)	(min)	(min)	(min)
EX-1	0.15	100	0.015	4.06	9.8	616	0.015	Unpaved	1.98	5.2	0	0.10	0.0	15
EX-2	0.15	100	0.015	4.06	9.8	900	0.015	Unpaved	1.98	7.6	-	-	0.0	17

Note: The time of concentration for each watershed was calculated using equations given in Chapter 3 of TR-55 - Urban Hydrology for Small Watersheds. Values for each overland "n" are taken from Table 3-1 of the previously reference manual.

CoRR Tracking Number : SDP23-00054

COPYRIGHT © HEDK Architects ALL RIGHTS RESERVED

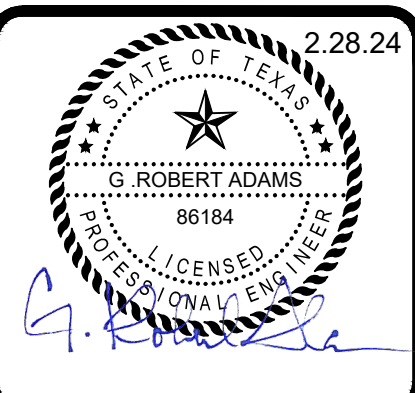
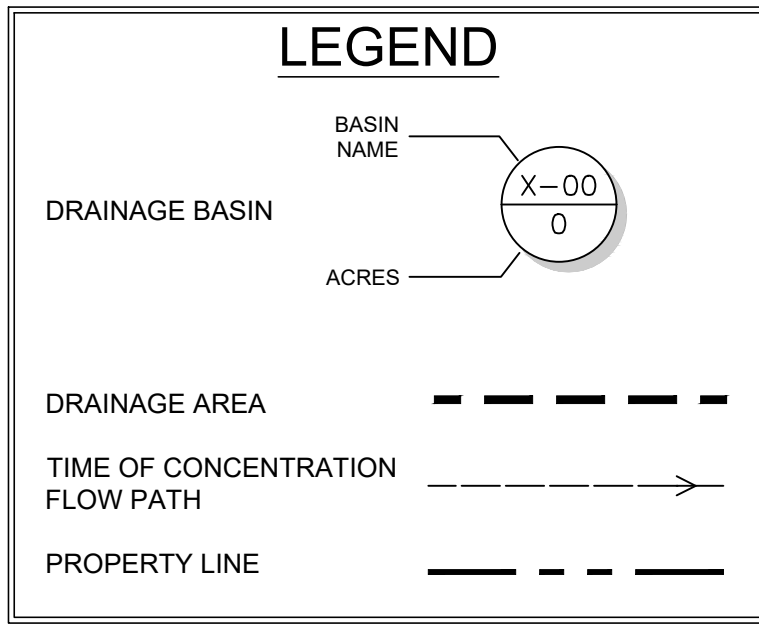
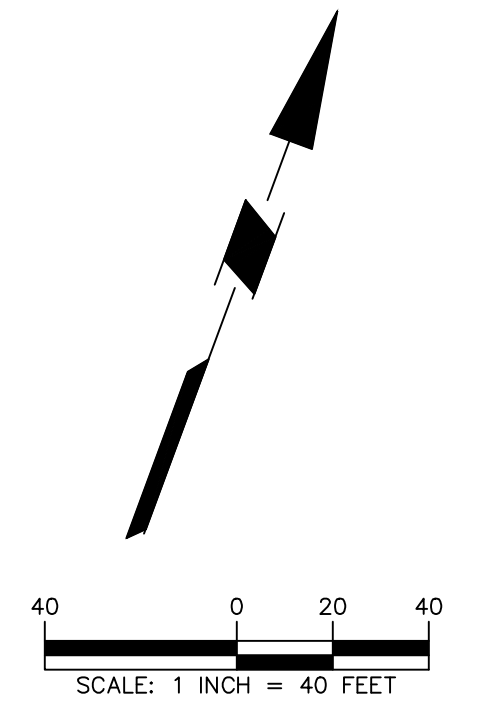
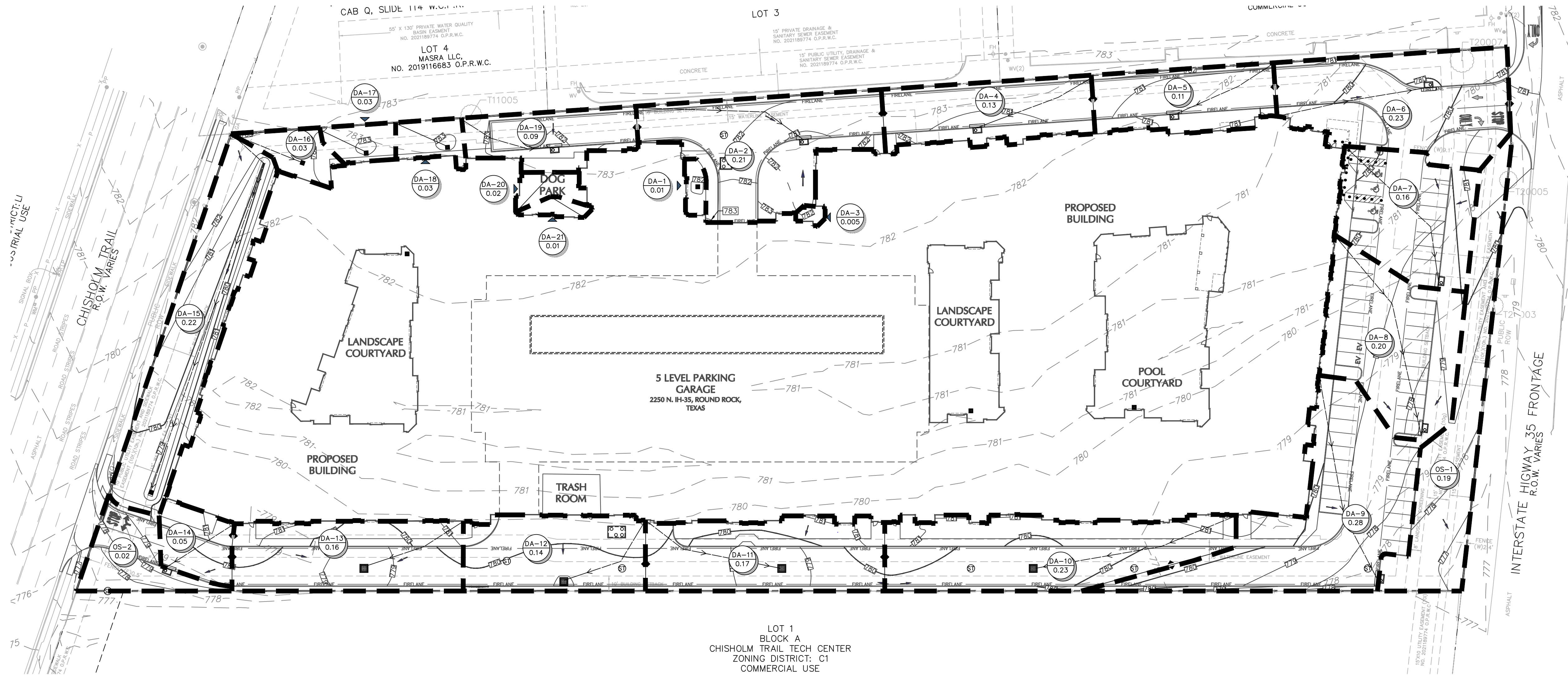

REVISIONS

NO.	DATE	DESCRIPTION

JADE AT CHISHOLM TRAIL
 392 APARTMENT UNITS IN ROUND ROCK, TEXAS
 GLENRIDGE DEVELOPMENT

PERMIT SET
 ISSUED 02-28-2024

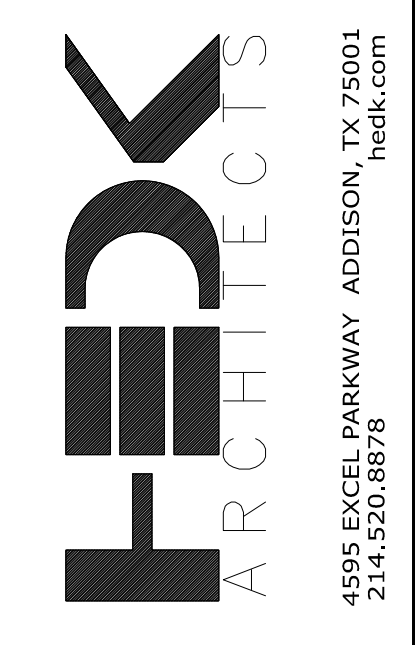

DATE
 02-28-2024

PROJECT
 22137

SHEET NUMBER
C6.01

PROPOSED DRAINAGE AREA MAP

POST-DEVELOPMENT DRAINAGE AREA CALCULATIONS

Drainage Area Designation	Drainage Area (ac)	Runoff Coefficient "C"				Time of Concentration (min)	Rainfall Intensity and Discharge									
		2-Yr	10-Yr	25-Yr	100-Yr		2-Year Peak Intensity (I2)	2-Year Peak Discharge (Q2)	10-Year Peak Intensity (I10)	10-Year Peak Discharge (Q10)	25-Year Peak Intensity (I25)	25-Year Peak Discharge (Q25)	100-Year Peak Intensity (I100)	100-Year Peak Discharge (Q100)		
DA-1	0.01	0.75	0.83	0.88	0.97	5	6.27	0.05	9.43	0.09	11.62	0.11	15.32	0.16		
DA-2	0.21	0.64	0.71	0.76	0.84	5	6.27	0.83	9.43	1.40	11.62	1.83	15.32	2.68		
DA-3	0.005	0.35	0.41	0.44	0.51	5	6.27	0.01	9.43	0.02	11.62	0.02	15.32	0.04		
DA-4	0.13	0.63	0.71	0.75	0.84	5	6.27	0.50	9.43	0.84	11.62	1.10	15.32	1.62		
DA-5	0.11	0.62	0.70	0.74	0.83	5	6.27	0.44	9.43	0.74	11.62	0.97	15.32	1.42		
DA-6	0.23	0.61	0.68	0.73	0.81	5	6.27	0.86	9.43	1.45	11.62	1.90	15.32	2.79		
DA-7	0.16	0.65	0.73	0.78	0.86	5	6.27	0.67	9.43	1.12	11.62	1.46	15.32	2.14		
DA-8	0.20	0.65	0.72	0.77	0.85	5	6.27	0.81	9.43	1.36	11.62	1.78	15.32	2.60		
DA-9	0.28	0.70	0.78	0.82	0.91	5	6.27	1.23	9.43	2.06	11.62	2.69	15.32	3.92		
DA-10	0.23	0.62	0.69	0.73	0.82	5	6.27	0.88	9.43	1.48	11.62	1.93	15.32	2.84		
DA-11	0.17	0.64	0.71	0.76	0.84	5	6.27	0.69	9.43	1.17	11.62	1.53	15.32	2.23		
DA-12	0.14	0.72	0.80	0.85	0.94	5	6.27	0.63	9.43	1.05	11.62	1.37	15.32	1.99		
DA-13	0.16	0.64	0.71	0.75	0.84	5	6.27	0.65	9.43	1.10	11.62	1.44	15.32	2.11		
DA-14	0.05	0.67	0.74	0.79	0.87	5	6.27	0.21	9.43	0.35	11.62	0.46	15.32	0.67		
DA-15	0.22	0.36	0.42	0.45	0.52	5	6.27	0.49	9.43	0.87	11.62	1.15	15.32	1.75		
DA-16	0.03	0.36	0.42	0.45	0.52	5	6.27	0.08	9.43	0.14	11.62	0.18	15.32	0.28		
DA-17	0.03	0.39	0.45	0.49	0.56	5	6.27	0.06	9.43	0.11	11.62	0.14	15.32	0.22		
DA-18	0.03	0.42	0.48	0.52	0.59	5	6.27	0.07	9.43	0.12	11.62	0.16	15.32	0.25		
DA-19	0.09	0.63	0.71	0.75	0.84	5	6.27	0.35	9.43	0.58	11.62	0.76	15.32	1.12		
DA-20	0.02	0.35	0.41	0.44	0.51	5	6.27	0.04	9.43	0.07	11.62	0.10	15.32	0.15		
DA-21	0.01	0.35	0.41	0.44	0.51	5	6.27	0.02	9.43	0.04	11.62	0.05	15.32	0.08		
Total	2.51							9.58		16.14		21.14		31.05		
OS-1	0.19	0.35	0.41	0.44	0.51	5	6.27	0.41	9.43	0.72	11.62	0.95	15.32	1.45		
OS-2	0.07	0.53	0.60	0.64	0.72	5	6.27	0.23	9.43	0.39	11.62	0.51	15.32	0.76		
Total	0.26							0.64		1.11		1.46		2.21		

Note: Calculations based on the Rational Method: Q = C*IA per the 2020 Round Rock Drainage Criteria Manual



THESE PLANS ARE SUBJECT TO REVIEW & APPROVAL BY JURISDICTIONAL ENTITIES.



LANGAN
 Langan Engineering and Environmental Services, Inc.
 9606 N. Mopac Expressway, Suite 110
 Austin, TX 78759
 T: 737.289.7800 F: 737.289.7801 www.langan.com
 TBPE FIRM REG. #F-13709

CoRR Tracking Number : SDP23-00054

COPYRIGHT © HEDK Architects ALL RIGHTS RESERVED

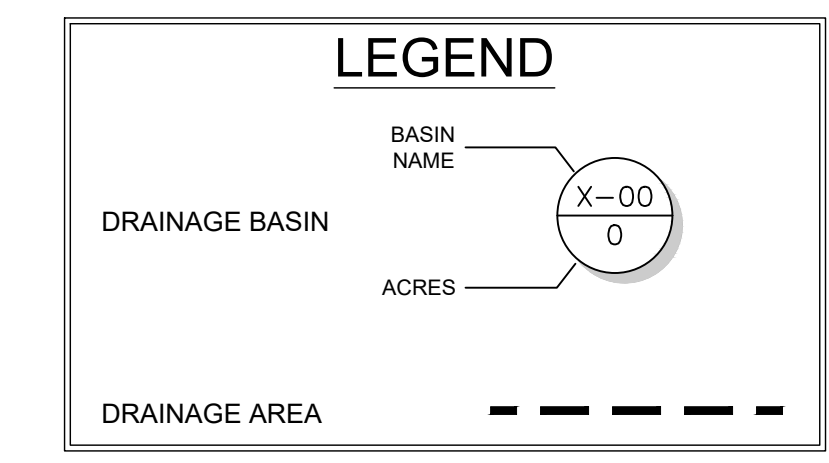
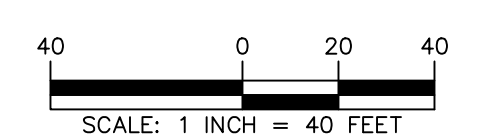
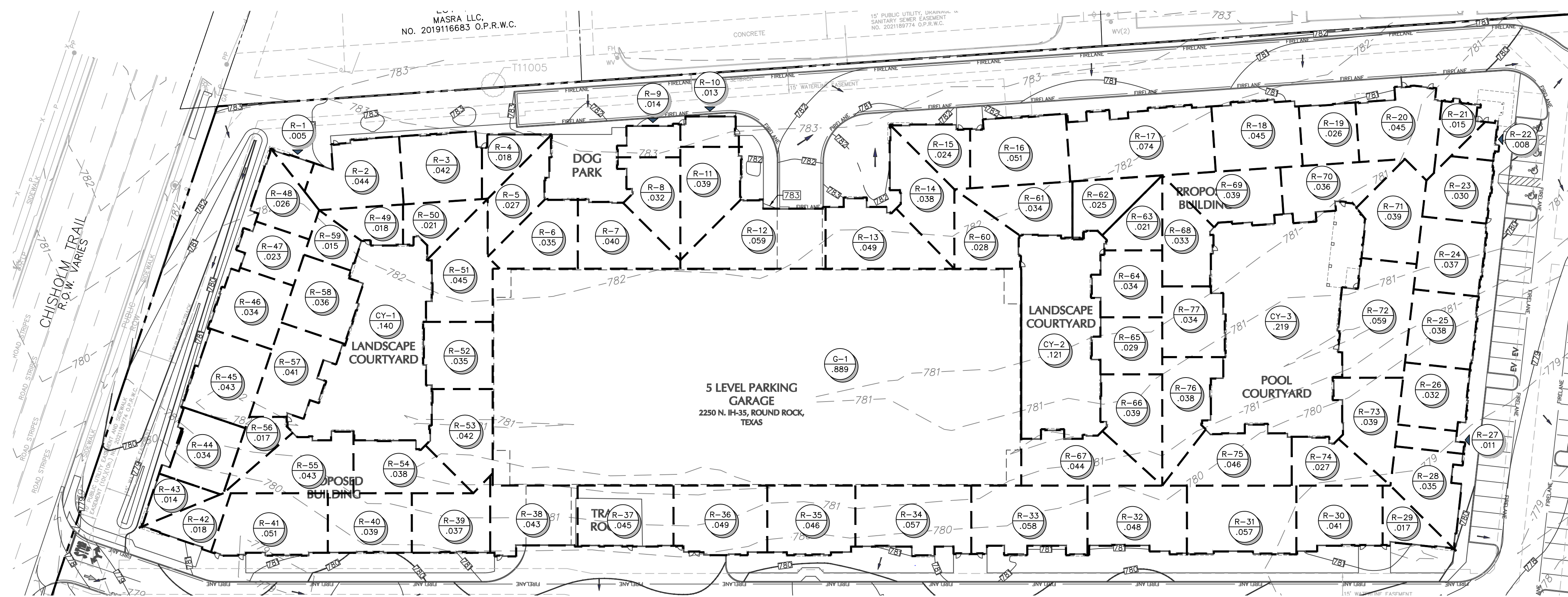

POST-DEVELOPMENT DRAINAGE AREA CALCULATIONS														
Drainage Area Designation	Drainage Area (ac)	Runoff Coefficient "C"				Time of Concentration (min)	2-Year	2-Year	10-Year	10-Year	25-Year	25-Year	100-Year	
		2-Yr	10-Yr	25-Yr	100-Yr		Rainfall Intensity (I2) (in/hr)	Peak Discharge (Q2) (cfs)	Rainfall Intensity (I10) (in/hr)	Peak Discharge (Q10) (cfs)	Rainfall Intensity (I25) (in/hr)	Peak Discharge (Q25) (cfs)	Rainfall Intensity (I100) (in/hr)	Peak Discharge (Q100) (cfs)
R-1	0.006	0.75	0.83	0.88	0.97	5	6.27	0.03	9.43	0.04	11.62	0.06	15.32	0.08
R-2	0.044	0.75	0.83	0.88	0.97	5	6.27	0.21	9.43	0.34	11.62	0.45	15.32	0.65
R-3	0.042	0.75	0.83	0.88	0.97	5	6.27	0.20	9.43	0.33	11.62	0.43	15.32	0.63
R-4	0.019	0.75	0.83	0.88	0.97	5	6.27	0.09	9.43	0.15	11.62	0.19	15.32	0.28
R-5	0.028	0.75	0.83	0.88	0.97	5	6.27	0.13	9.43	0.22	11.62	0.28	15.32	0.41
R-6	0.035	0.75	0.83	0.88	0.97	5	6.27	0.17	9.43	0.28	11.62	0.36	15.32	0.52
R-7	0.040	0.75	0.83	0.88	0.97	5	6.27	0.19	9.43	0.31	11.62	0.41	15.32	0.60
R-8	0.032	0.75	0.83	0.88	0.97	5	6.27	0.15	9.43	0.25	11.62	0.33	15.32	0.48
R-9	0.014	0.75	0.83	0.88	0.97	5	6.27	0.07	9.43	0.11	11.62	0.14	15.32	0.21
R-10	0.013	0.75	0.83	0.88	0.97	5	6.27	0.06	9.43	0.10	11.62	0.14	15.32	0.20
R-11	0.039	0.75	0.83	0.88	0.97	5	6.27	0.18	9.43	0.30	11.62	0.40	15.32	0.58
R-12	0.061	0.75	0.83	0.88	0.97	5	6.27	0.29	9.43	0.48	11.62	0.62	15.32	0.90
R-13	0.049	0.75	0.83	0.88	0.97	5	6.27	0.23	9.43	0.38	11.62	0.50	15.32	0.73
R-14	0.038	0.75	0.83	0.88	0.97	5	6.27	0.18	9.43	0.30	11.62	0.39	15.32	0.57
R-15	0.024	0.75	0.83	0.88	0.97	5	6.27	0.11	9.43	0.19	11.62	0.24	15.32	0.35
R-16	0.051	0.75	0.83	0.88	0.97	5	6.27	0.24	9.43	0.40	11.62	0.52	15.32	0.76
R-17	0.074	0.75	0.83	0.88	0.97	5	6.27	0.35	9.43	0.58	11.62	0.76	15.32	1.11
R-18	0.045	0.75	0.83	0.88	0.97	5	6.27	0.21	9.43	0.36	11.62	0.46	15.32	0.67
R-19	0.026	0.75	0.83	0.88	0.97	5	6.27	0.12	9.43	0.21	11.62	0.27	15.32	0.39
R-20	0.044	0.75	0.83	0.88	0.97	5	6.27	0.21	9.43	0.35	11.62	0.45	15.32	0.66
R-21	0.018	0.75	0.83	0.88	0.97	5	6.27	0.08	9.43	0.14	11.62	0.18	15.32	0.27
R-22	0.010	0.75	0.83	0.88	0.97	5	6.27	0.05	9.43	0.08	11.62	0.11	15.32	0.15
R-23	0.030	0.75	0.83	0.88	0.97	5	6.27	0.14	9.43	0.23	11.62	0.30	15.32	0.44
R-24	0.038	0.75	0.83	0.88	0.97	5	6.27	0.18	9.43	0.29	11.62	0.38	15.32	0.56
R-25	0.038	0.75	0.83	0.88	0.97	5	6.27	0.18	9.43	0.30	11.62	0.39	15.32	0.56
R-26	0.032	0.75	0.83	0.88	0.97	5	6.27	0.15	9.43	0.25	11.62	0.33	15.32	0.47
R-27	0.011	0.75	0.83	0.88	0.97	5	6.27	0.05	9.43	0.09	11.62	0.11	15.32	0.16
R-28	0.036	0.75	0.83	0.88	0.97	5	6.27	0.17	9.43	0.28	11.62	0.37	15.32	0.53
R-29	0.018	0.75	0.83	0.88	0.97	5	6.27	0.08	9.43	0.14	11.62	0.18	15.32	0.27
R-30	0.041	0.75	0.83	0.88	0.97	5	6.27	0.19	9.43	0.32	11.62	0.42	15.32	0.61
R-31	0.058	0.75	0.83	0.88	0.97	5	6.27	0.27	9.43	0.45	11.62	0.59	15.32	0.86
R-32	0.049	0.75	0.83	0.88	0.97	5	6.27	0.23	9.43	0.38	11.62	0.50	15.32	0.72
R-33	0.059	0.75	0.83	0.88	0.97	5	6.27	0.28	9.43	0.46	11.62	0.60	15.32	0.87
R-34	0.058	0.75	0.83	0.88	0.97	5	6.27	0.27	9.43	0.45	11.62	0.59	15.32	0.86
R-35	0.047	0.75	0.83	0.88	0.97	5	6.27	0.22	9.43	0.37	11.62	0.48	15.32	0.69
R-36	0.049	0.75	0.83	0.88	0.97	5	6.27	0.23	9.43	0.39	11.62	0.50	15.32	0.73
R-37	0.045	0.75	0.83	0.88	0.97	5	6.27	0.21	9.43	0.36	11.62	0.46	15.32	0.67
R-38	0.043	0.75	0.83	0.88	0.97	5	6.27	0.20	9.43	0.34	11.62	0.44	15.32	0.64
R-39	0.038	0.75	0.83	0.88	0.97	5	6.27	0.18	9.43	0.29	11.62	0.38	15.32	0.56
R-40	0.039	0.75	0.83	0.88	0.97	5	6.27	0.18	9.43	0.31	11.62	0.40	15.32	0.58
R-41	0.051	0.75	0.83	0.88	0.97	5	6.27	0.24	9.43	0.40	11.62	0.52	15.32	0.76
R-42	0.019	0.75	0.83	0.88	0.97	5	6.27	0.09	9.43	0.15	11.62	0.19	15.32	0.28
R-43	0.014	0.75	0.83	0.88	0.97	5	6.27	0.07	9.43	0.11	11.62	0.15	15.32	0.21
R-44	0.034	0.75	0.83	0.88	0.97	5	6.27	0.16	9.43	0.27	11.62	0.35	15.32	0.51
R-45	0.043	0.75	0.83	0.88	0.97	5	6.27	0.20	9.43	0.34	11.62	0.44	15.32	0.64
R-46	0.035	0.75	0.83	0.88	0.97	5	6.27	0.16	9.43	0.27	11.62	0.36	15.32	0.52
R-47	0.023	0.75	0.83	0.88	0.97	5	6.27	0.11	9.43	0.18	11.62	0.24	15.32	0.35
R-48	0.026	0.75	0.83	0.88	0.97	5	6.27	0.12	9.43	0.21	11.62	0.27	15.32	0.39
R-49	0.017	0.75	0.83	0.88	0.97	5	6.27	0.08	9.43	0.13	11.62	0.18	15.32	0.26
R-50	0.021	0.75	0.83	0.88	0.97	5	6.27	0.10	9.43	0.16	11.62	0.21	15.32	0.31
R-51	0.045	0.75	0.83	0.88	0.97	5	6.27	0.21	9.43	0.35	11.62	0.46	15.32	0.66
R-52	0.036	0.75	0.83	0.88	0.97	5	6.27	0.17	9.43	0.28	11.62	0.37	15.32	0.53
R-53	0.042	0.75	0.83	0.88	0.97	5	6.27	0.20	9.43	0.33	11.62	0.42	15.32	0.62
R-54	0.038	0.75	0.83	0.88	0.97	5	6.27	0.18	9.43	0.29	11.62	0.39	15.32	0.56
R-55	0.043	0.75	0.83	0.88	0.97	5	6.27	0.20	9.43	0.34	11.62	0.44	15.32	0.64
R-56	0.016	0.75	0.83	0.88	0.97	5	6.27	0.08	9.43	0.13	11.62	0.17	15.32	0.24
R-57	0.040	0.75	0.83	0.88	0.97	5	6.27	0.19	9.43	0.31	11.62	0.41	15.32	0.59
R-58	0.036	0.75	0.83	0.88	0.97	5	6.27	0.17	9.43	0.28	11.62	0.37	15.32	0.54
R-59	0.016	0.75	0.83	0.88	0.97	5	6.27	0.07	9.43	0.12	11.62	0.16	15.32	0.24
R-60	0.028	0.75	0.83	0.88	0.97	5	6.27	0.13	9.43	0.22	11.62	0.29	15.32	0.42
CY-1	0.140	0.75	0.83	0.88	0.97	5	6.27	0.50	9.43	1.10	11.62	1.10	15.32	1.63
CY-2	0.121	0.58	0.65	0.70	0.78	5	6.27	0.45	9.43	0.76	11.62	0.99	15.32	1.46
CY-3	0.219	0.62	0.69	0.74	0.82	5	6.27	0.85	9.43	1.43	11.62	1.88	15.32	2.75
G-1	0.889	0.75	0.83	0.88	0.97	5	6.27	4.18	9.43	6.96	11.62	9.09	15.32	13.21
Total	4.09							18.77		31.28		40.89		59.46

POST-DEVELOPMENT DRAINAGE AREA CALCULATIONS														
Drainage Area Designation	Drainage Area (ac)	Runoff Coefficient "C"				Time of Concentration (min)	2-Year	2-Year	10-Year	10-Year	25-Year	25-Year	100-Year	
		2-Yr	10-Yr	25-Yr	100-Yr		Rainfall Intensity (I2) (in/hr)	Peak Discharge (Q2) (cfs)	Rainfall Intensity (I10) (in/hr)	Peak Discharge (Q10) (cfs)	Rainfall Intensity (I25) (in/hr)	Peak Discharge (Q25) (cfs)	Rainfall Intensity (I100) (in/hr)	Peak Discharge (Q100) (cfs)
R-61	0.034	0.75	0.83	0.88	0.97	5	6.27	0.16	9.43	0.27	11.62	0.35	15.32	0.51
R-62	0.025	0.75	0.83	0.88	0.97	5	6.27	0.12	9.43	0.20	11.62	0.26	15.32	0.38
R-63	0.020	0.75	0.83	0.88	0.97	5	6.27	0.09	9.43	0.16	11.62	0.20	15.32	0.30
R-64	0.033	0.75	0.83	0.88	0.97	5	6.27	0.15	9.43	0.26	11.62	0.33	15.32	0.49
R-65	0.029	0.75	0.83	0.88	0.97	5	6.27	0.14	9.43	0.23	11.62	0.30	15.32	0.43
R-66	0.039	0.75	0.83	0.88	0.97	5	6.27	0.19	9.43	0.31	11.62	0.40	15.32	0.59
R-67	0.044	0.75	0.83	0.88	0.97	5	6.27	0.21	9.43	0.35	11.62	0.45	15.32	0.66
R-68	0.031	0.75	0.83	0.88	0.97	5	6.27	0.14	9.43	0.24	11.62	0.31	15.32	0.46
R-69	0.039	0.75	0.83	0.88	0.97	5	6.27	0.18	9.43	0.30	11.62	0.40	15.32	0.58
R-70	0.036	0.75	0.83	0.88	0.97	5	6.27	0.17	9.43	0.28	11.62	0.37	15.32	0.54
R-71	0.039	0.75	0.83	0.88	0.97	5	6.27	0.19	9.43	0.31	11.62	0.40	15.32	0.59
R-72	0.061	0.75	0.83	0.88	0.97	5	6.27	0.29	9.43	0.48	11.62	0.63	15.32	0.91
R-73	0.039	0.75	0.83	0.88	0.97	5	6.27	0.18	9.43	0.31	11.62	0.40	15.32	0.58
R-74	0.027	0.75	0.83	0.88	0.97	5	6.27	0.13	9.43	0.21	11.62	0.27	15.32	0.40
R-75	0.046	0.75	0.83	0.88	0.97	5	6.27	0.21	9.43	0.36	11.62	0.47	15.32	0.68
R-76	0.038	0.75	0.83	0.88	0.97	5	6.27	0.18	9.43	0.30	11.62	0.39	15.32	0.56
R-77	0.034	0.75	0.83	0.88	0.97	5	6.27	0.16	9.43	0.26	11.62</			

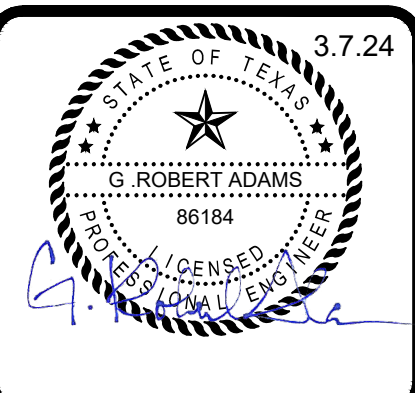

REVISIONS

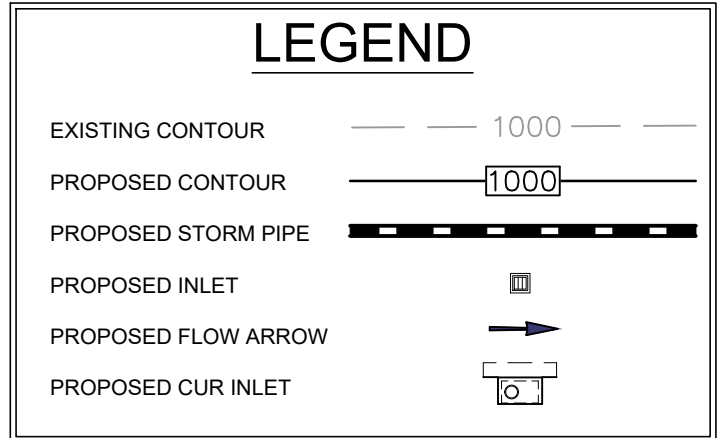
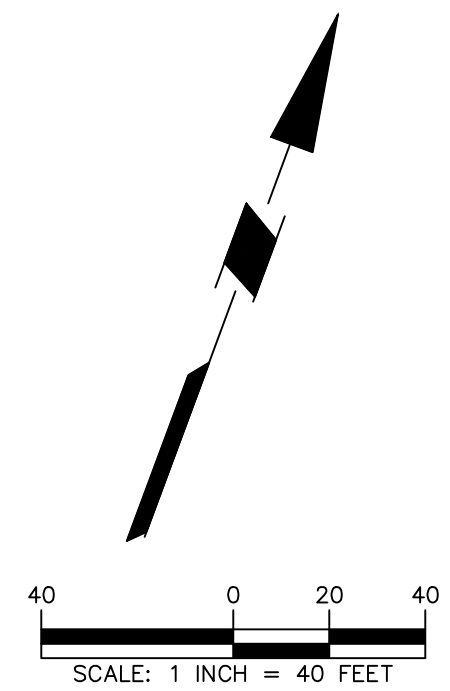

- CIVIL DRAIN NOTE**
1. ALL CIVIL STORM DRAIN LINES 15" AND SMALLER CONNECTING TO ROOF DRAIN OR DOWNSPOUT SHOWN BY ARCH/MEP SHALL BE SCH-40 PVC OR BETTER.
 2. CIVIL DRAINAGE CONTRACTOR SHALL INSTALL CONNECTING DOWNSPOUT DRAIN LINES PER CIVIL AND ARCHITECTURAL DETAILS TO THE FACE OF THE BUILDING AND TERMINATING ABOVE GROUND SURFACE UNLESS COORDINATED OTHERWISE.
 3. WHERE CIVIL LINE SIZE AND ROOF DRAIN / DOWNSPOUT SIZE DO NOT MATCH, CONTRACTOR TO SUPPLY AND INSTALL REDUCER AS REQUIRED FOR THE CONNECTION.
 4. CONTRACTOR TO SUPPLY AND INSTALL A PREMANUFACTURED FITTING AT ALL PVC CONNECTIONS TO HDPE TRUNK LINE.
 5. REFER TO SHEET C6.04 FOR LATERAL STORM PIPES
 6. REFER TO SHEET C6.04 FOR ROOF DRAINAGE PLAN

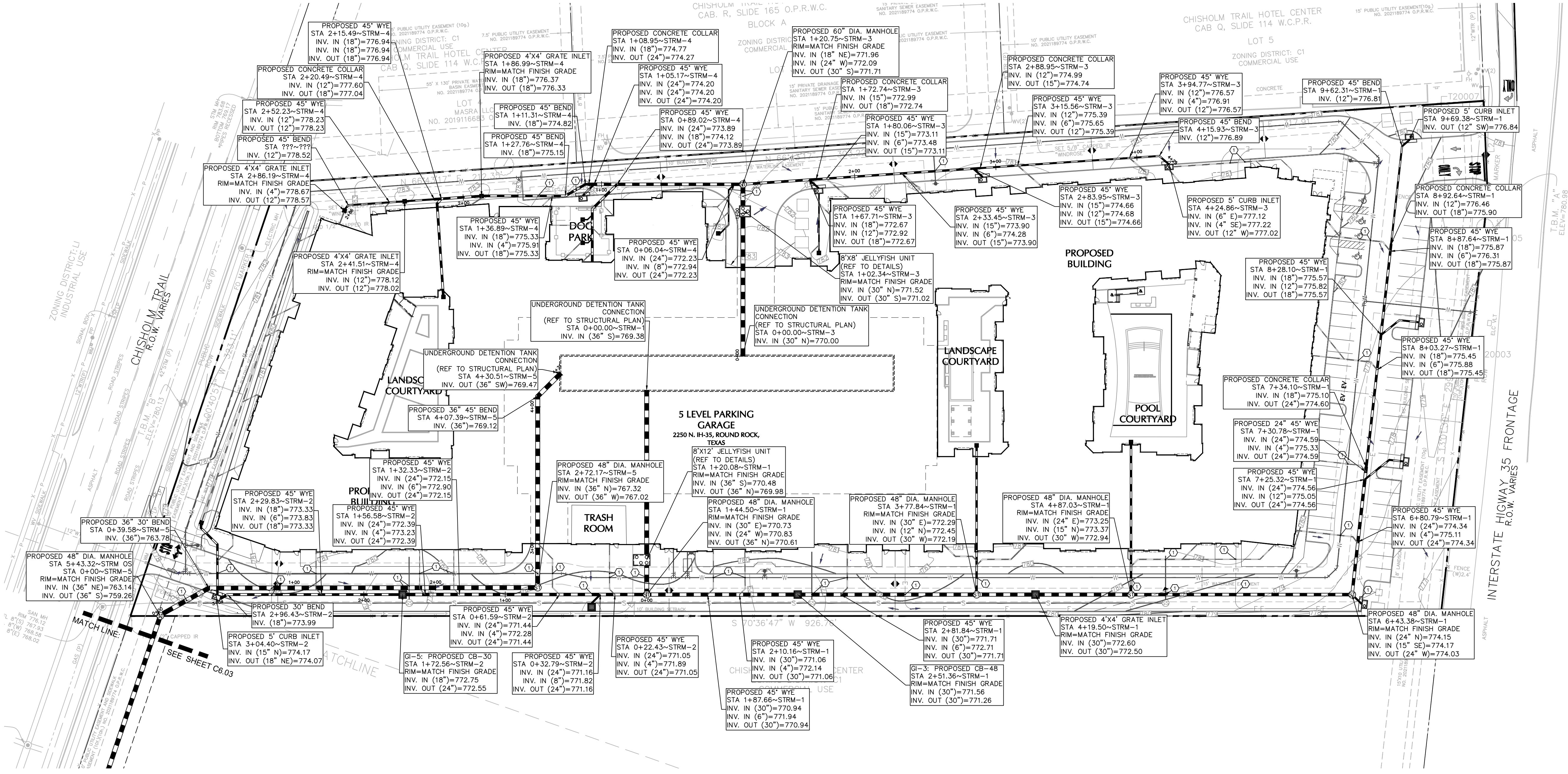
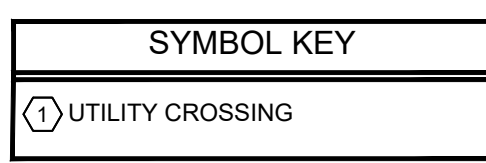

OVERALL SITE DRAINAGE PLAN - MAIN LINES

**** NOTICE TO CONTRACTORS - TOPOGRAPHIC SURVEY ****

TOPOGRAPHIC INFORMATION TAKEN FROM A TOPOGRAPHIC SURVEY PERFORMED BY WINDROSE LAND SERVICES, LLC. THE CONTRACTOR SHALL NOTIFY THE ENGINEER IMMEDIATELY, IN WRITING, OF ANY DISCREPANCIES OR OMISSIONS TO THE TOPOGRAPHIC INFORMATION. THE CONTRACTOR(S) SHALL BE RESPONSIBLE FOR CONFIRMING THE LOCATION (HORIZONTAL/VERTICAL) OF ANY BURIED CABLES, CONDUITS, PIPES, AND STRUCTURES (STORM SEWER, SANITARY SEWER, WATER, GAS, TELEVISION, TELEPHONE, ETC.) WHICH IMPACT THE CONSTRUCTION SITE. THE CONTRACTOR(S) SHALL NOTIFY THE OWNER AND ENGINEER IF ANY DISCREPANCIES ARE FOUND BETWEEN THE ACTUAL CONDITIONS VERSUS THE DATA CONTAINED IN THE CONSTRUCTION PLANS. ANY COSTS INCURRED AS THE RESULT OF NOT CONFIRMING THE ACTUAL LOCATION (HORIZONTAL/VERTICAL) OF SAID CABLES, CONDUITS, PIPES, AND STRUCTURES SHALL BE BORNE BY THE CONTRACTOR. ADDITIONALLY, THE CONTRACTOR(S) SHALL NOTIFY THE OWNER AND ENGINEER IF ANY ERRORS OR DISCREPANCIES ARE FOUND ON THE CONSTRUCTION DOCUMENTS (PS&E), WHICH NEGATIVELY IMPACT THE PROJECT. THE ENGINEER AND OWNER SHALL BE INDEMNIFIED OF PROBLEMS AND/OR COST WHICH MAY RESULT FROM CONTRACTOR'S FAILURE TO NOTIFY ENGINEER AND OWNER.

****NOTICE TO CONTRACTORS - UTILITIES****

THE CONTRACTOR IS SPECIFICALLY CAUTIONED THAT THE LOCATION AND/OR ELEVATION OF ANY EXISTING UTILITIES AS SHOWN ON THESE PLANS ARE BASED ON RECORDS OF THE VARIOUS UTILITY COMPANIES, THE GOVERNING MUNICIPALITY, AND WHERE POSSIBLE, MEASUREMENTS TAKEN IN THE FIELD. THE INFORMATION PROVIDED IS NOT TO BE RELIED ON AS BEING EXACT OR COMPLETE. THE CONTRACTOR MUST CALL THE APPROPRIATE UTILITY COMPANY AT LEAST 48 HOURS BEFORE ANY EXCAVATION TO REQUEST EXACT FIELD LOCATION OF UTILITIES. IT SHALL BE THE RESPONSIBILITY OF THE CONTRACTOR TO RELOCATE ALL EXISTING UTILITIES WHICH CONFLICT WITH THE PROPOSED IMPROVEMENTS SHOWN ON THESE PLANS.



THESE PLANS ARE SUBJECT TO REVIEW & APPROVAL BY JURISDICTIONAL ENTITIES.

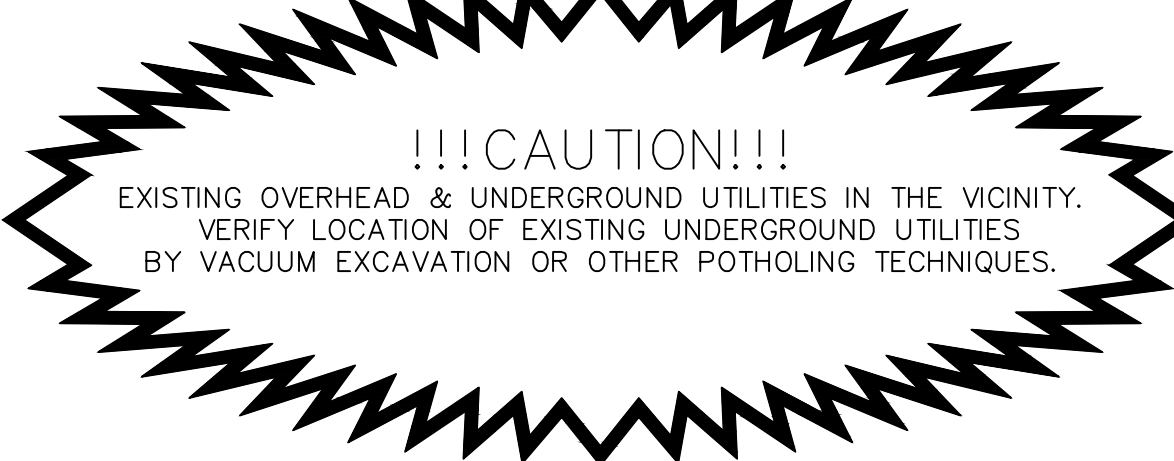

LANGAN
Langan Engineering and Environmental Services, Inc.
9606 N. Mopac Expressway, Suite 110
Austin, TX 78759
T: 737.289.7800 F: 737.289.7801 www.langan.com
TXBE FIRM REG. #F-13709

JADE AT CHISHOLM TRAIL
392 APARTMENT UNITS IN ROUND ROCK, TEXAS
GLENRIDGE DEVELOPMENT

PERMIT SET
ISSUED 02-28-2024

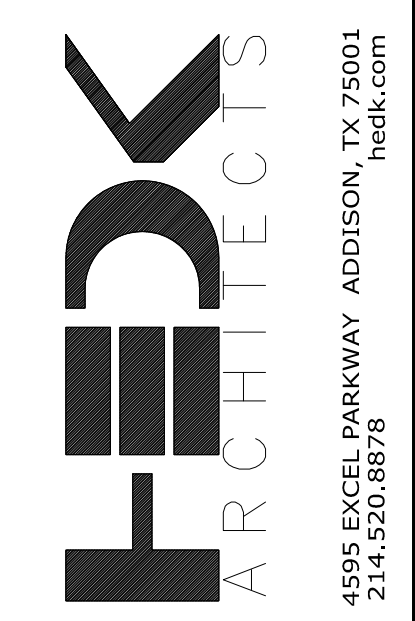

DATE: 02-28-2024
PROJECT: 22137
SHEET NUMBER: C6.03
DRAINAGE PLAN (1 OF 2)

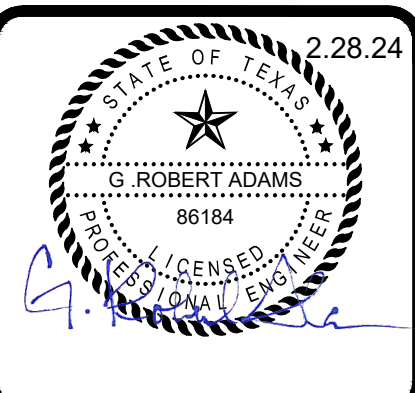

REVISIONS

NO.	DATE	DESCRIPTION

JADE AT CHISHOLM TRAIL
 392 APARTMENT UNITS IN ROUND ROCK, TEXAS
 GLENRIDGE DEVELOPMENT

PERMIT SET
 ISSUED 02-28-2024

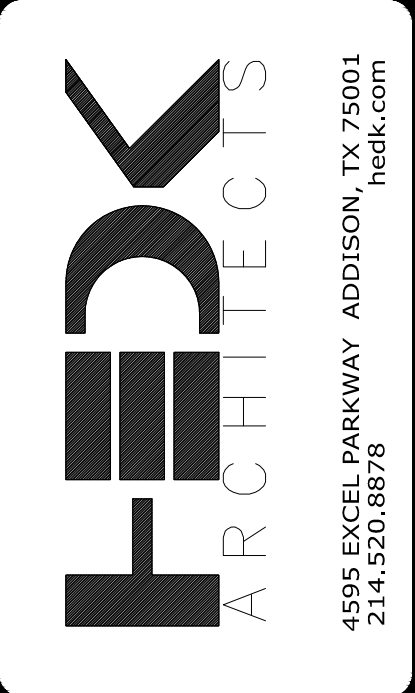

DATE: 02-28-2024
 PROJECT: 22137
 SHEET NUMBER: C6.04
 DRAINAGE PLAN (2 OF 2)

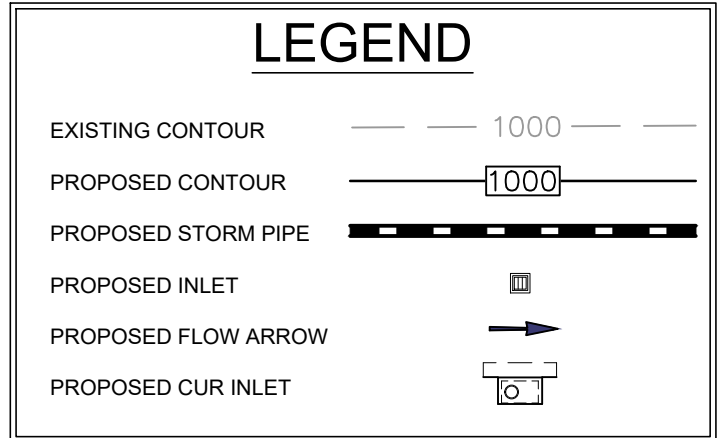
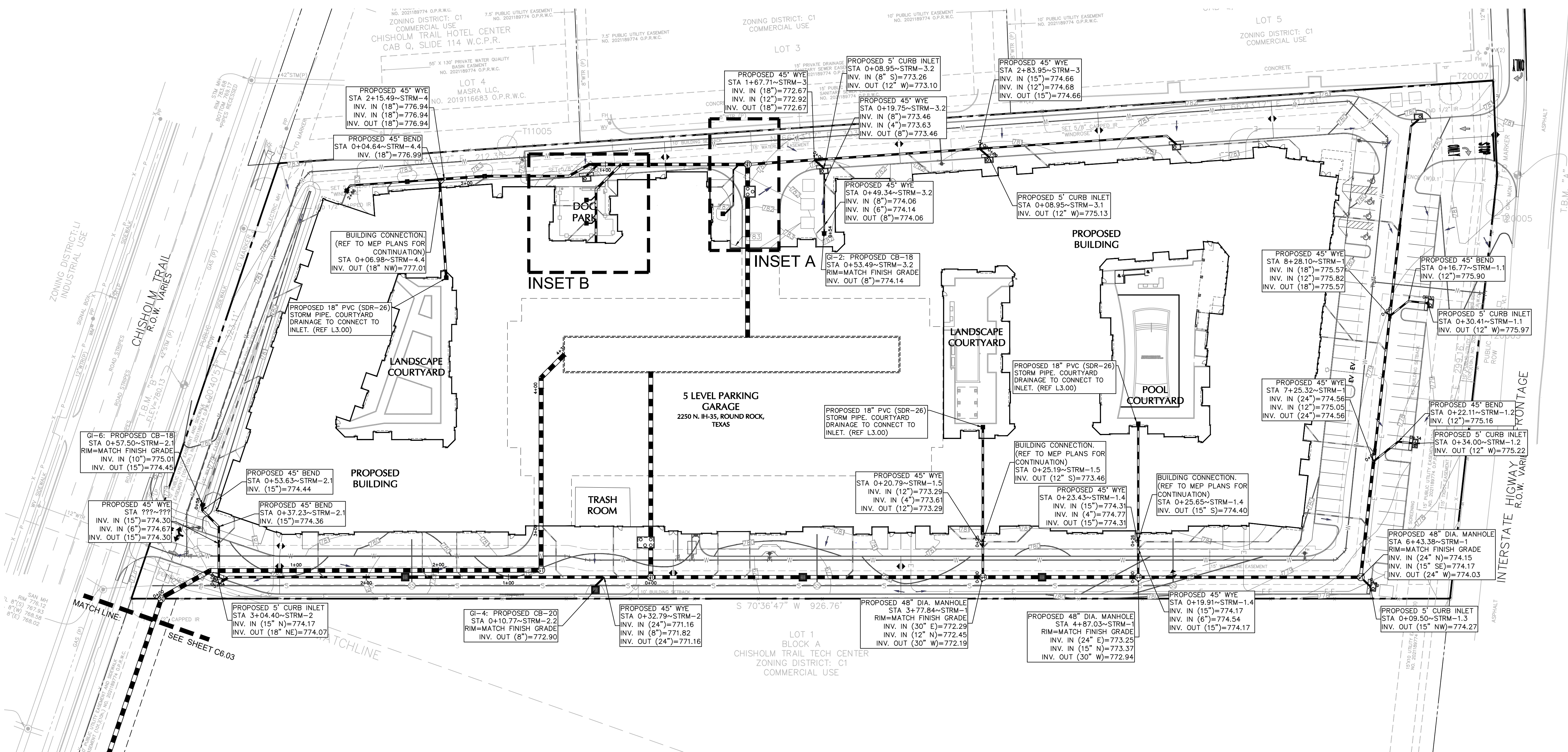

- CIVIL DRAIN NOTE**
- ALL CIVIL STORM DRAIN LINES 15" AND SMALLER CONNECTING TO ROOF DRAIN OR DOWNSPOUT SHOWN BY ARCH/MEP SHALL BE SCH-40 PVC OR BETTER.
 - CIVIL DRAINAGE CONTRACTOR SHALL INSTALL CONNECTING DOWNSPOUT DRAIN LINES PER CIVIL AND ARCHITECTURAL DETAILS TO THE FACE OF THE BUILDING AND TERMINATING ABOVE GROUND SURFACE UNLESS COORDINATED OTHERWISE.
 - WHERE CIVIL LINE SIZE AND ROOF DRAIN / DOWNSPOUT SIZE DO NOT MATCH, CONTRACTOR TO SUPPLY AND INSTALL REDUCER AS REQUIRED FOR THE CONNECTION.
 - CONTRACTOR TO SUPPLY AND INSTALL A PREMANUFACTURED FITTING AT ALL PVC CONNECTIONS TO HDPE TRUNK LINE.
 - REFER TO SHEET C6.04 FOR LATERAL STORM PIPES
 - REFER TO SHEET C6.04 FOR ROOF DRAINAGE PLAN

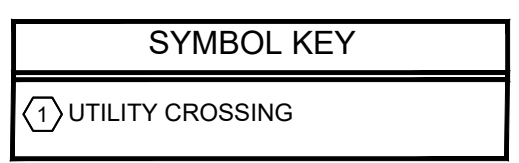

OVERALL SITE DRAINAGE PLAN - LATERAL LINES

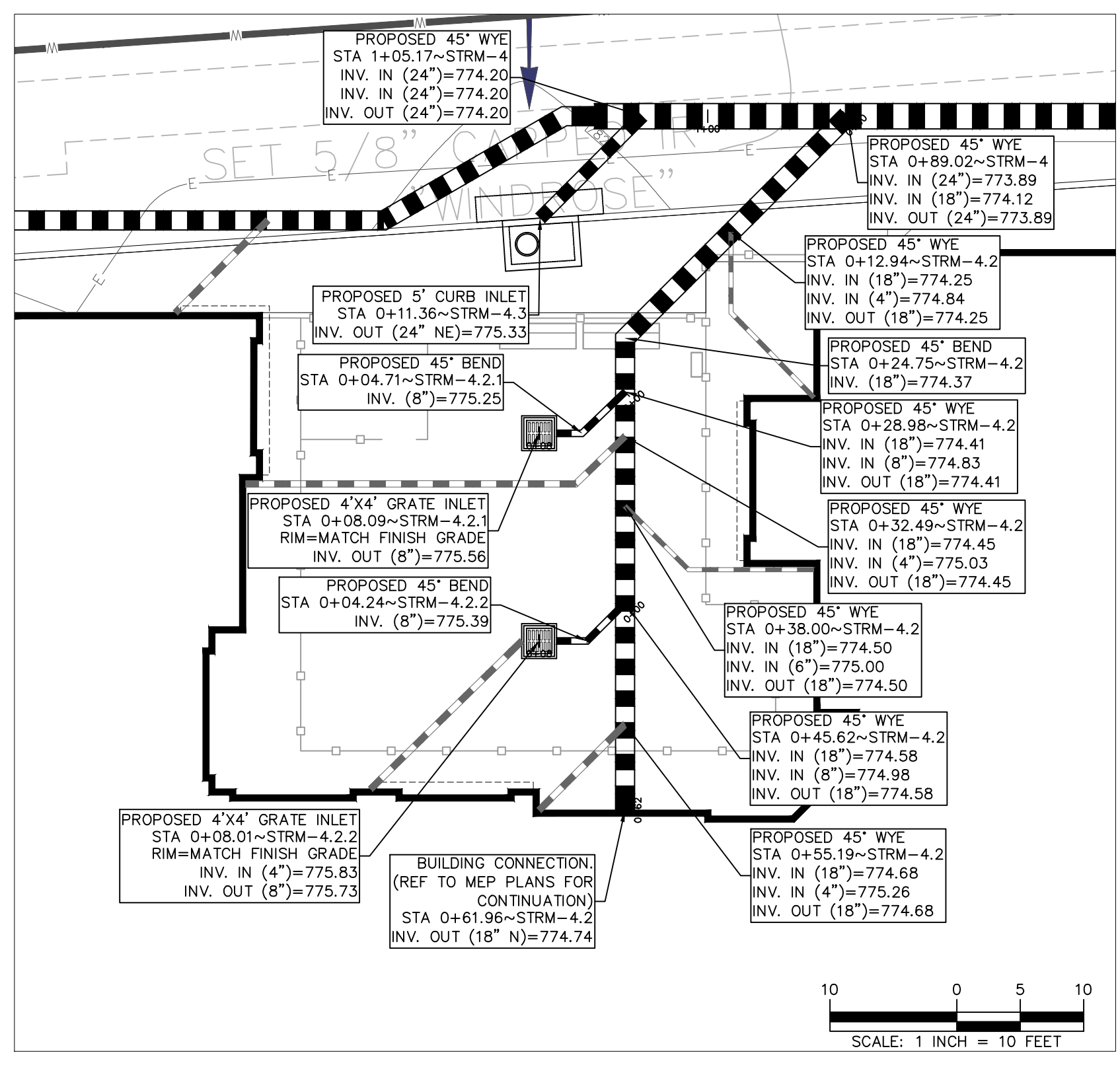
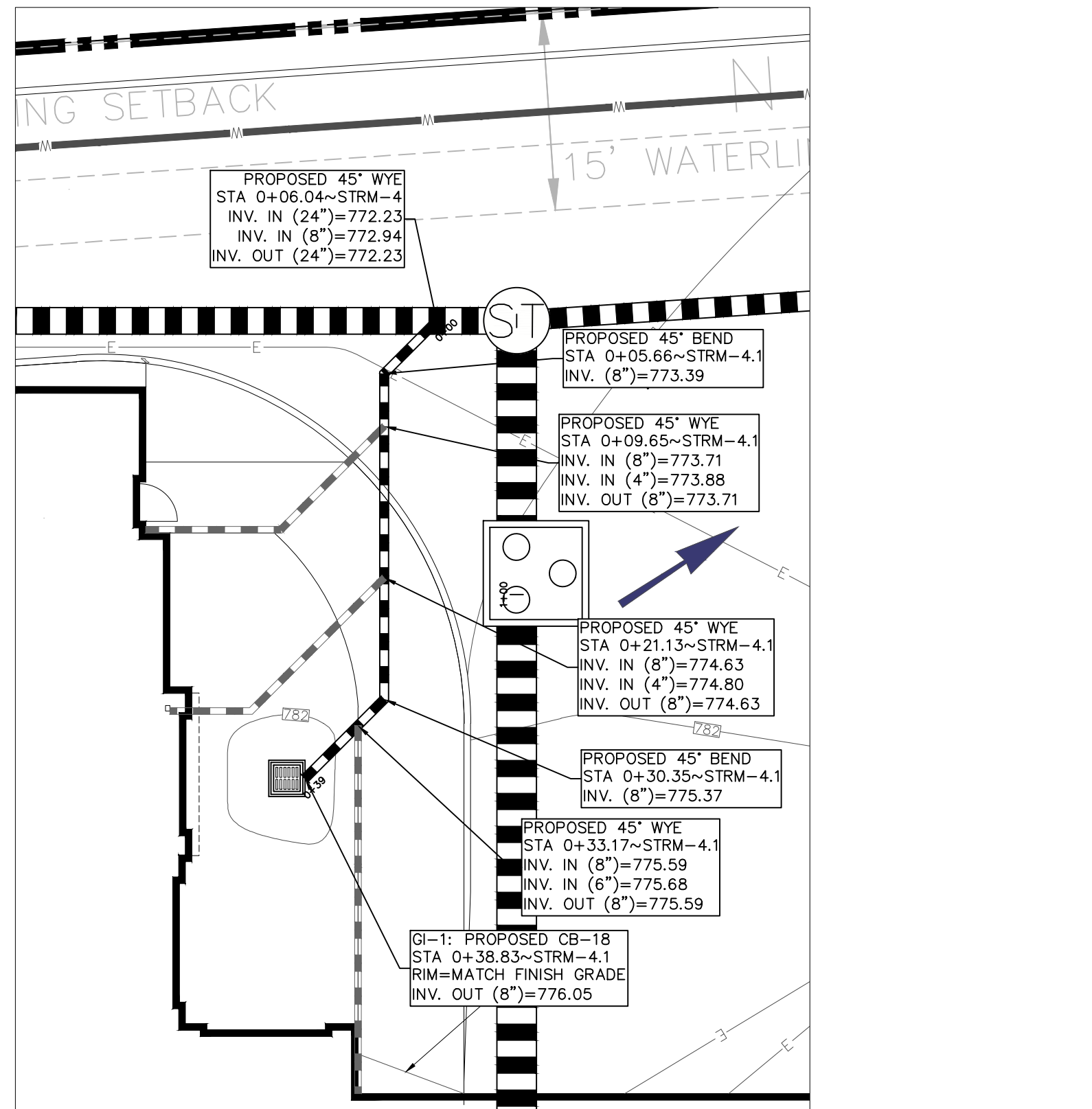

**** NOTICE TO CONTRACTORS - TOPOGRAPHIC SURVEY ****

TOPOGRAPHIC INFORMATION TAKEN FROM A TOPOGRAPHIC SURVEY PERFORMED BY WINDROSE LAND SERVICES, LLC. THE CONTRACTOR SHALL NOTIFY THE ENGINEER IMMEDIATELY, IN WRITING, OF ANY DISCREPANCIES OR OMISSIONS TO THE TOPOGRAPHIC INFORMATION. THE CONTRACTOR(S) SHALL BE RESPONSIBLE FOR CONFIRMING THE LOCATION (HORIZONTAL/VERTICAL) OF ANY BURIED CABLES, CONDUITS, PIPES, AND STRUCTURES (STORM SEWER, SANITARY SEWER, WATER, GAS, TELEVISION, TELEPHONE, ETC.) WHICH IMPACT THE CONSTRUCTION SITE. THE CONTRACTOR(S) SHALL NOTIFY THE OWNER AND ENGINEER IF ANY DISCREPANCIES ARE FOUND BETWEEN THE ACTUAL CONDITIONS VERSUS THE DATA CONTAINED IN THE CONSTRUCTION PLANS. ANY COSTS INCURRED AS THE RESULT OF NOT CONFIRMING THE ACTUAL LOCATION (HORIZONTAL/VERTICAL) OF SAID CABLES, CONDUITS, PIPES, AND STRUCTURES SHALL BE BORNE BY THE CONTRACTOR. ADDITIONALLY, THE CONTRACTOR(S) SHALL NOTIFY THE OWNER AND ENGINEER IF ANY ERRORS OR DISCREPANCIES ARE FOUND ON THE CONSTRUCTION DOCUMENTS (PS&E), WHICH NEGATIVELY IMPACT THE PROJECT. THE ENGINEER AND OWNER SHALL BE INDEMNIFIED OF PROBLEMS AND/OR COST WHICH MAY RESULT FROM CONTRACTOR'S FAILURE TO NOTIFY ENGINEER AND OWNER.

****NOTICE TO CONTRACTORS - UTILITIES****

THE CONTRACTOR IS SPECIFICALLY CAUTIONED THAT THE LOCATION AND/OR ELEVATION OF ANY EXISTING UTILITIES AS SHOWN ON THESE PLANS ARE BASED ON RECORDS OF THE VARIOUS UTILITY COMPANIES, THE GOVERNING MUNICIPALITY, AND WHERE POSSIBLE, MEASUREMENTS TAKEN IN THE FIELD. THE INFORMATION PROVIDED IS NOT TO BE RELIED ON AS BEING EXACT OR COMPLETE. THE CONTRACTOR MUST CALL THE APPROPRIATE UTILITY COMPANY AT LEAST 48 HOURS BEFORE ANY EXCAVATION TO REQUEST EXACT FIELD LOCATION OF UTILITIES. IT SHALL BE THE RESPONSIBILITY OF THE CONTRACTOR TO RELOCATE ALL EXISTING UTILITIES WHICH CONFLICT WITH THE PROPOSED IMPROVEMENTS SHOWN ON THESE PLANS.



THESE PLANS ARE SUBJECT TO REVIEW & APPROVAL BY JURISDICTIONAL ENTITIES.



LANGAN
 Langan Engineering and Environmental Services, Inc.
 9606 N. Mopac Expressway, Suite 110
 Austin, TX 78759
 T: 737.289.7800 F: 737.289.7801 www.langan.com
 TBPE FIRM REG. #F-13709

CoRR Tracking Number : SDP23-00054

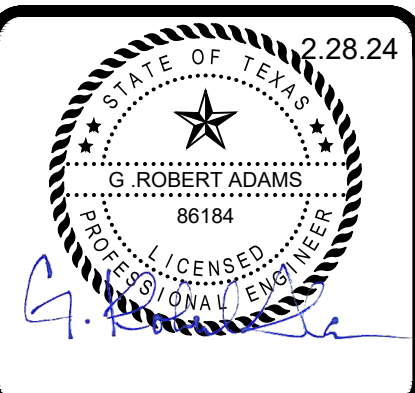

REVISIONS

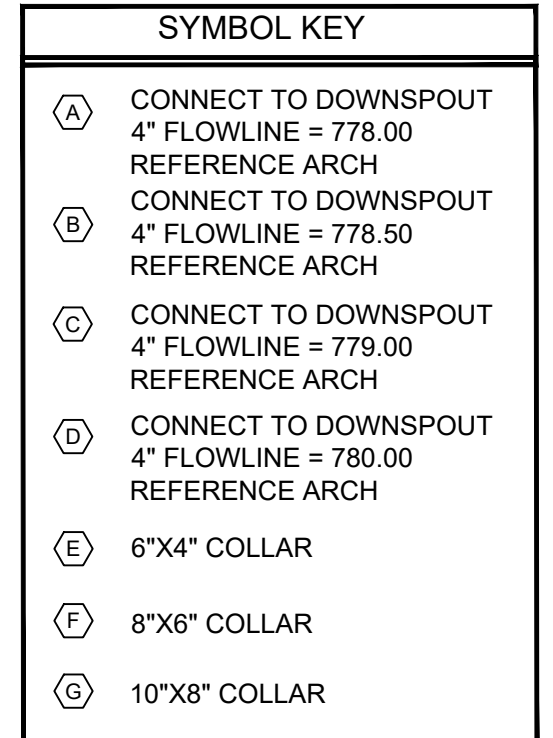
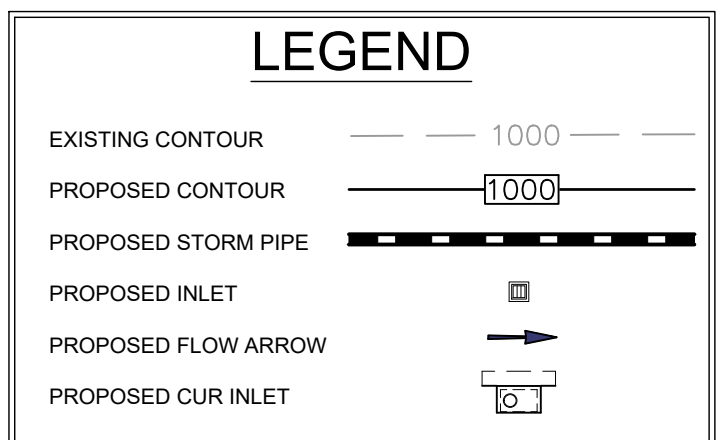
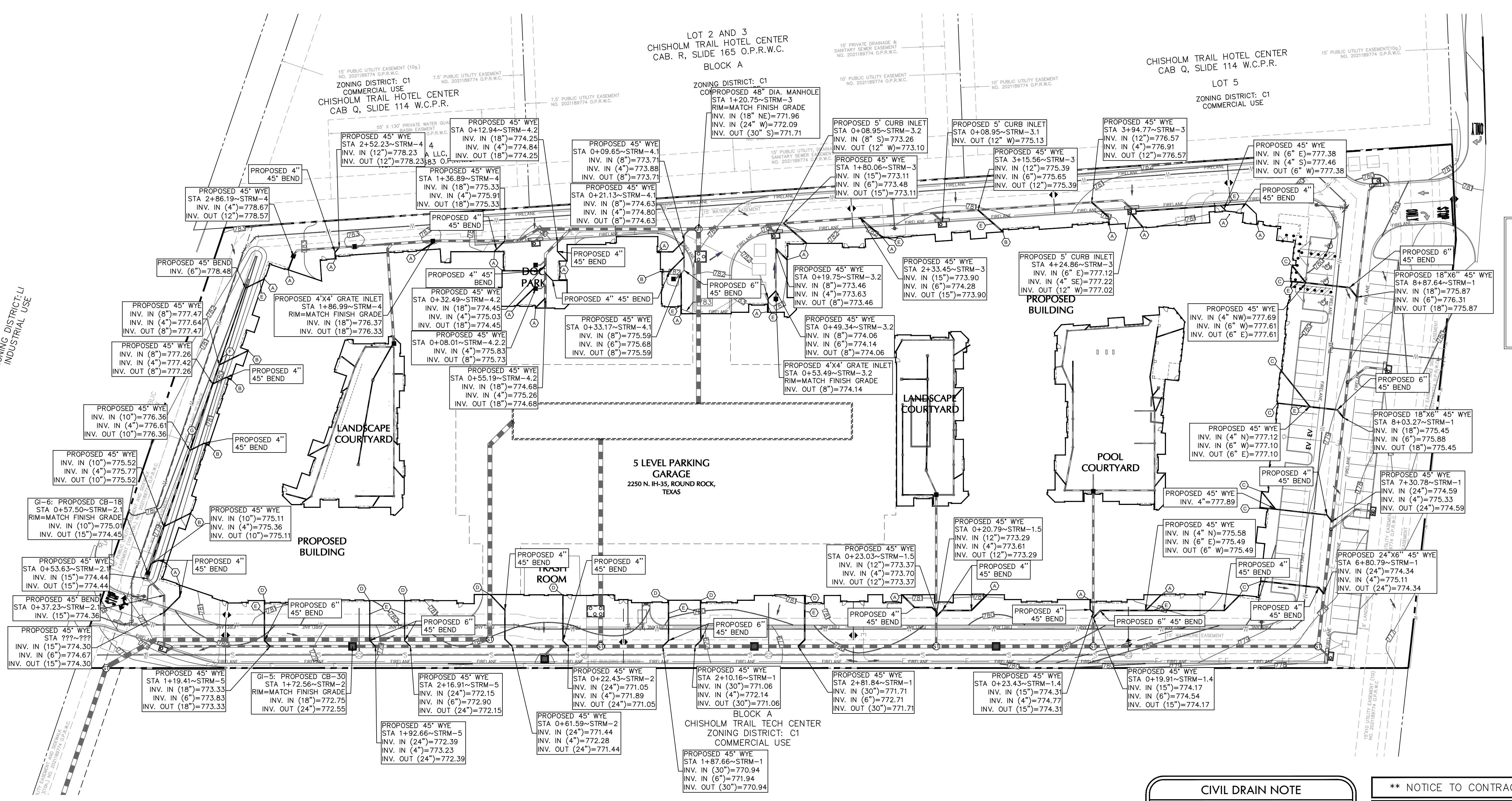
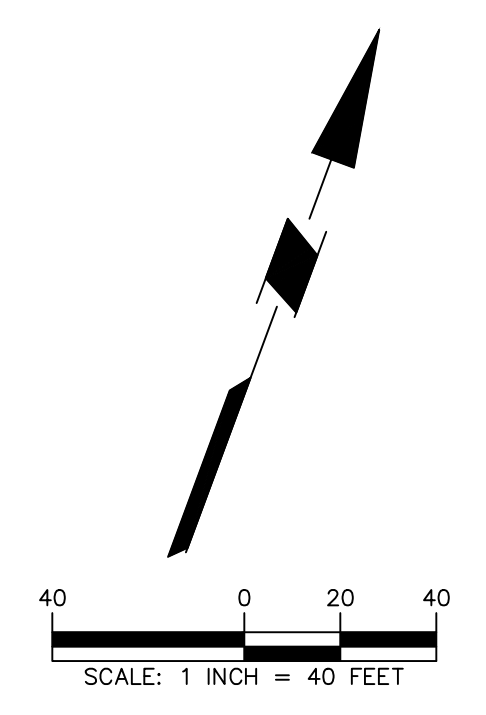

CIVIL DRAIN NOTE

1. ALL CIVIL STORM DRAIN LINES 12\"/>
2. CIVIL DRAINAGE CONTRACTOR SHALL INSTALL CONNECTING DOWNSPOUT DRAIN LINES PER CIVIL AND ARCHITECTURAL DETAILS TO THE FACE OF THE BUILDING AND TERMINATING ABOVE GROUND SURFACE UNLESS COORDINATED OTHERWISE.
3. WHERE CIVIL LINE SIZE AND ROOF DRAIN / DOWNSPOUT SIZE DO NOT MATCH, CONTRACTOR TO SUPPLY AND INSTALL REDUCER AS REQUIRED FOR THE CONNECTION.
4. CONTRACTOR TO SUPPLY AND INSTALL A PREMANUFACTURED FITTING AT ALL PVC CONNECTIONS TO HDPE TRUNK LINE.

**** NOTICE TO CONTRACTORS - TOPOGRAPHIC SURVEY ****

TOPOGRAPHIC INFORMATION TAKEN FROM A TOPOGRAPHIC SURVEY PERFORMED BY WINDROSE LAND SERVICES, LLC. THE CONTRACTOR SHALL NOTIFY THE ENGINEER IMMEDIATELY, IN WRITING, OF ANY DISCREPANCIES OR OMISSIONS TO THE TOPOGRAPHIC INFORMATION. THE CONTRACTOR(S) SHALL BE RESPONSIBLE FOR CONFIRMING THE LOCATION (HORIZONTAL/VERTICAL) OF ANY BURIED CABLES, CONDUITS, PIPES, AND STRUCTURES (STORM SEWER, SANITARY SEWER, WATER, GAS, TELEVISION, TELEPHONE, ETC.) WHICH IMPACT THE CONSTRUCTION SITE. THE CONTRACTOR(S) SHALL NOTIFY THE OWNER AND ENGINEER IF ANY DISCREPANCIES ARE FOUND BETWEEN THE ACTUAL CONDITIONS VERSUS THE DATA CONTAINED IN THE CONSTRUCTION PLANS. ANY COSTS INCURRED AS THE RESULT OF NOT CONFIRMING THE ACTUAL LOCATION (HORIZONTAL/VERTICAL) OF SAID CABLES, CONDUITS, PIPES, AND STRUCTURES SHALL BE BORNE BY THE CONTRACTOR. ADDITIONALLY, THE CONTRACTOR(S) SHALL NOTIFY THE OWNER AND ENGINEER IF ANY ERRORS OR DISCREPANCIES ARE FOUND ON THE CONSTRUCTION DOCUMENTS (PS&E), WHICH NEGATIVELY IMPACT THE PROJECT. THE ENGINEER AND OWNER SHALL BE INDEMNIFIED OF PROBLEMS AND/OR COST WHICH MAY RESULT FROM CONTRACTOR'S FAILURE TO NOTIFY ENGINEER AND OWNER.

****NOTICE TO CONTRACTORS - UTILITIES****

THE CONTRACTOR IS SPECIFICALLY CAUTIONED THAT THE LOCATION AND/OR ELEVATION OF ANY EXISTING UTILITIES AS SHOWN ON THESE PLANS ARE BASED ON RECORDS OF THE VARIOUS UTILITY COMPANIES, THE GOVERNING MUNICIPALITY, AND WHERE POSSIBLE, MEASUREMENTS TAKEN IN THE FIELD. THE INFORMATION PROVIDED IS NOT TO BE RELIED ON AS BEING EXACT OR COMPLETE. THE CONTRACTOR MUST CALL THE APPROPRIATE UTILITY COMPANY AT LEAST 48 HOURS BEFORE ANY EXCAVATION TO REQUEST EXACT FIELD LOCATION OF UTILITIES. IT SHALL BE THE RESPONSIBILITY OF THE CONTRACTOR TO RELOCATE ALL EXISTING UTILITIES WHICH CONFLICT WITH THE PROPOSED IMPROVEMENTS SHOWN ON THESE PLANS.

JADE AT CHISHOLM TRAIL

392 APARTMENT UNITS IN ROUND ROCK, TEXAS

GLENRIDGE DEVELOPMENT

PERMIT SET
ISSUED 02-28-2024

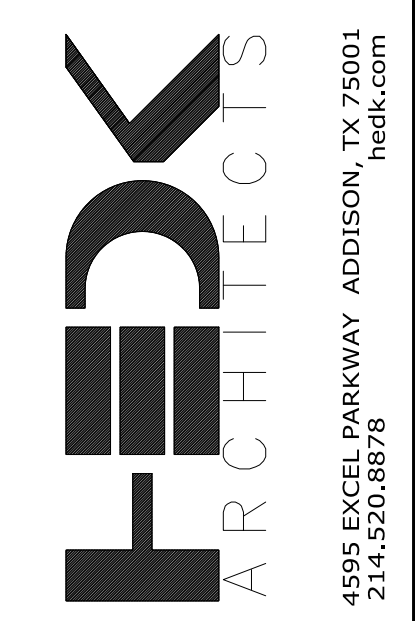

DATE
02-28-2024

PROJECT
22137

SHEET NUMBER
C6.05

ROOF DRAINAGE
PLAN



THESE PLANS ARE SUBJECT TO REVIEW & APPROVAL BY JURISDICTIONAL ENTITIES.



LANGAN

Langan Engineering and Environmental Services, Inc.
9606 N. Mopac Expressway, Suite 110
Austin, TX 78759
T: 737.289.7800 F: 737.289.7801 www.langan.com
TBPE FIRM REG. #F-13709

CoRR Tracking Number : SDP23-00054

COPYRIGHT © HEDK Architects ALL RIGHTS RESERVED

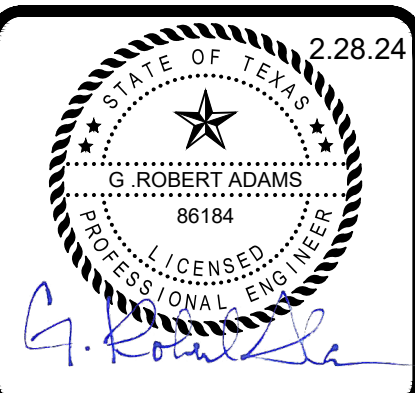

REVISIONS

JADE AT CHISHOLM TRAIL
 392 APARTMENT UNITS IN ROUND ROCK, TEXAS
 GLENRIDGE DEVELOPMENT

PERMIT SET
 ISSUED 02-28-2024

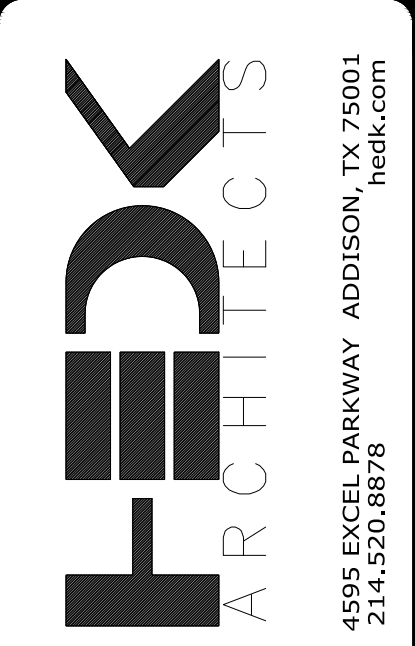

DATE
 02-28-2024

PROJECT
 22137

SHEET NUMBER
 C6.11
 DRAINAGE CALCULATIONS
 (1 OF 3)

HYDRAULIC CALCULATIONS

Line ID	Upstream Station	Downstream Station	Pipe Length (ft)	Pipe Slope (ft/ft)	Drainage Area Designation	Incremental Drainage Area (ac)	Cumulative Drainage Area (ac)	Runoff Coefficient "C"	Incremental "CA"	Cumulative "CA"	Time at Inlet (min)	Time in Pipe (min)	Cumulative Time (min)	Rainfall Intensity (in/hr)	Peak Flow (cfs)	Pipe Material	Pipe Capacity (cfs)	Pipe Diameter (in)	Friction Slope (ft/ft)	Hydraulic Gradient		Velocity In (ft/sec)	Velocity Out (ft/sec)	V1^2/2g (ft)	V2^2/2g (ft)	Upstream Junction Type	Loss Coefficient "K"	Velocity Head Loss (ft)	Upstream Invert Elev. (ft)	Downstream Invert Elev. (ft)	Comments
																				Upstream	Downstream										
STRM-1	9+69.38	9+62.31	7.07	0.0050	DA-6	0.23	0.23	0.81	0.18	0.18	5.00	0.03	5.03	15.32	2.8	HDPE	3.0	12	0.0044	777.83	777.80	0.00	3.55	0.00	0.20	Begin Line	1.25	0.24	774.65	774.61	
STRM-1	9+62.31	8+92.64	69.67	0.0050	None	0.00	0.23	0.00	0.00	0.18	5.03	0.33	5.36	15.29	2.8	HDPE	3.0	12	0.0044	777.70	777.40	3.55	3.55	0.20	0.20	45 Bend	0.35	0.10	774.61	774.26	
STRM-1	8+92.64	8+87.64	5.00	0.0050	None	0.00	0.23	0.00	0.00	0.18	5.36	0.02	5.38	15.02	2.7	HDPE	3.0	12	0.0042	777.30	777.28	3.55	3.48	0.20	0.19	Collar-18 to 21	0.10	0.10	774.26	774.24	
STRM-1	8+87.64	8+28.10	59.54	0.0050	R-22,R-23	0.04	0.26	0.97	0.04	0.22	5.38	0.53	5.92	15.00	3.3	HDPE	8.0	18	0.0007	777.18	777.13	3.48	1.86	0.19	0.05	45 Wye	0.75	0.10	774.24	773.94	
STRM-1	8+28.10	8+03.27	24.83	0.0050	DA-7	0.16	0.43	0.86	0.14	0.36	5.92	0.14	6.06	14.58	5.2	HDPE	8.8	18	0.0018	777.03	776.99	1.86	2.96	0.05	0.14	45 Wye	0.75	0.10	773.94	773.82	
STRM-1	8+03.27	7+34.10	69.17	0.0050	R-24,R-25	0.08	0.50	0.97	0.07	0.43	6.06	0.33	6.38	14.47	6.2	HDPE	8.8	18	0.0025	776.89	776.71	2.96	3.54	0.14	0.19	45 Wye	0.75	0.10	773.82	773.47	
STRM-1	7+34.10	7+30.78	3.32	0.0050	None	0.00	0.50	0.00	0.00	0.43	6.38	0.03	6.41	14.24	6.1	HDPE	18.9	24	0.0005	776.61	776.61	3.54	1.96	0.19	0.06	Collar-18 to 21	0.10	0.10	773.47	773.45	
STRM-1	7+30.78	7+25.32	5.46	0.0050	R-26,R-27	0.04	0.54	0.97	0.04	0.47	6.41	0.04	6.46	14.22	6.7	HDPE	18.9	24	0.0006	776.51	776.51	1.96	2.14	0.06	0.07	45 Wye	0.75	0.10	773.45	773.43	
STRM-1	7+25.32	6+80.79	44.53	0.0050	DA-8	0.20	0.74	0.85	0.17	0.64	6.46	0.26	6.71	14.19	9.1	HDPE	18.9	24	0.0012	776.41	776.36	2.14	2.90	0.07	0.13	45 Wye	0.75	0.10	773.43	773.20	
STRM-1	6+80.79	6+43.38	37.41	0.0050	R-28	0.04	0.78	0.97	0.03	0.68	6.71	0.21	6.92	14.01	9.5	HDPE	18.9	24	0.0013	776.26	776.21	2.90	3.02	0.13	0.14	45 Wye	0.75	0.10	773.20	773.02	
STRM-1	6+43.38	4+87.03	156.35	0.0050	DA-9	0.28	1.06	0.91	0.26	0.93	6.92	0.63	7.55	13.87	12.9	HDPE	18.9	24	0.0023	776.02	775.65	3.02	4.12	0.14	0.26	MH with 45 Lateral	0.50	0.19	773.02	772.24	
STRM-1	4+87.03	4+19.50	67.53	0.0050	R-29-31,CY-3,R68-77	0.73	1.78	0.93	0.67	1.61	7.55	0.26	7.80	13.47	21.6	HDPE	34.3	30	0.0020	775.42	775.28	4.12	4.41	0.26	0.30	MH with 90 Lateral	0.25	0.24	772.24	771.90	
STRM-1	4+19.50	3+77.84	41.66	0.0050	DA-10	0.23	2.01	0.82	0.19	1.79	7.80	0.14	7.95	13.31	23.9	HDPE	34.3	30	0.0024	775.06	774.96	4.41	4.86	0.30	0.37	Inlet	0.50	0.22	771.90	771.69	
STRM-1	3+77.84	2+81.84	96.00	0.0050	R-32-33,CY-2,R-60-67	0.48	2.49	0.92	0.45	2.24	7.95	0.27	8.21	13.22	29.6	HDPE	34.3	30	0.0037	774.49	774.13	4.86	6.03	0.37	0.57	MH with 90 Lateral	0.25	0.47	771.69	771.21	
STRM-1	2+81.84	2+51.36	30.48	0.0050	R-34	0.06	2.55	0.97	0.06	2.29	8.21	0.03	8.30	13.07	30.0	HDPE	34.3	30	0.0038	773.98	773.86	6.03	6.11	0.57	0.58	45 Wye	0.75	0.16	771.21	771.06	
STRM-1	2+51.36	2+10.16	41.20	0.0050	DA-11	0.17	2.72	0.84	0.15	2.44	8.30	0.11	8.40	13.02	31.8	HDPE	34.3	30	0.0043	773.50	773.32	6.11	6.48	0.58	0.65	Inlet	0.50	0.36	771.06	770.85	
STRM-1	2+10.16	1+87.66	22.50	0.0050	R-35	0.05	2.77	0.97	0.04	2.49	8.40	0.06	8.46	12.96	32.2	HDPE	34.3	30	0.0044	773.14	773.04	6.48	6.57	0.65	0.67	45 Wye	0.75	0.18	770.85	770.74	
STRM-1	1+87.66	1+44.50	43.16	0.0050	R-36	0.05	2.82	0.97	0.05	2.53	8.46	0.11	8.57	12.93	32.7	HDPE	34.3	30	0.0046	772.85	772.65	6.57	6.68	0.67	0.69	45 Wye	0.75	0.19	770.74	770.52	
STRM-1	1+44.50	1+20.08	24.42	0.0050	STRM-2	0.41	3.23	2.02	0.82	3.35	8.57	0.07	8.63	12.83	43.2	HDPE	55.7	36	0.0030	772.55	772.48	6.68	6.11	0.69	0.58	MH	1.00	0.10	770.52	770.40	
STRM-1	1+20.08	0+00.00	120.08	0.0050	None	0.00	3.23	0.00	0.00	3.35	8.63	0.33	8.96	12.83	43.0	HDPE	55.7	36	0.0030	772.38	0.00	6.11	6.09	0.58	0.58	MH	1.00	0.10	770.40	769.80	
STRM-1.1	0+30.41	0+16.77	13.64	0.0050	DA-7	0.16	0.16	0.86	0.14	0.14	5.00	0.08	5.08	15.32	2.1	HDPE	3.0	12	0.0026	777.00	776.96	0.00	2.72	0.00	0.12	Begin Line	1.25	0.14	775.97	775.90	
STRM-1.1	0+16.77	0+00.00	16.77	0.0050	None	0.00	0.16	0.00	0.00	0.14	5.08	0.10	5.19	15.25	2.1	HDPE	3.0	12	0.0026	776.86	776.82	2.72	2.71	0.12	0.11	45 Bend	0.35	0.10	775.90	775.82	
STRM-1.2	0+34.00	0+22.11	11.89	0.0050	DA-8	0.20	0.20	0.85	0.17	0.17	5.00	0.06	5.06	15.32	2.6	HDPE	3.0	12	0.0038	776.28	776.23	0.00	3.31	0.00	0.17	Begin Line	1.25	0.21	775.22	775.16	
STRM-1.2	0+22.11	0+00.00	22.11	0.0050	None	0.00	0.20	0.00	0.00	0.17	5.06	0.11	5.17	15.27	2.6	HDPE	3.0	12	0.0038	776.13	776.05	3.31	3.30	0.17	0.17	45 Bend	0.35	0.10	775.16	775.05	
STRM-1.3	0+09.50	0+00.00	9.50	0.0100	DA-9	0.28	0.28	0.91	0.26	0.26	5.00	0.05	5.05	15.32	3.9	HDPE	7.6	15	0.0026	775.45	775.42	0.00	3.20	0.00	0.16	Begin Line	1.25	0.20	774.27	774.17	
STRM-1.4	0+25.65	0+23.43	2.22	0.0400	R-68-77,CY-3	0.61	0.61	0.92	0.56	0.56	5.00	0.01	5.01	15.32	8.6	PVC	18.7	15	0.0085	774.62	774.61	0.00	7.01	0.00	0.76	Begin Line	1.25	0.96	773.37	773.28	
STRM-1.4	0+23.43	0+19.91	3.52	0.0400	R-31	0.06	0.67	0.97	0.06	0.62	5.01	0.01	5.01	15.31	9.5	PVC	18.7	15	0.0103	774.26	774.22	7.01	7.71	0.76	0.92	45 Wye	0.75	0.35	773.28	773.14	
STRM-1.4	0+19.91	0+18.94	0.97	0.0400	R-29,R-30	0.06	0.73	0.97	0.06	0.67	5.01	0.00	5.01	15.31	10.3	PVC	18.7	15	0.0122	773.81	0.00	7.71	8.41	0.92	1.10	45 Wye	0.75	0.41	773.14	773.10	
STRM-1.5	0+25.19	0+24.19	1.00	0.0400	CY-2,R-60-67	0.38	0.38	0.51	0.19	0.19	5.00	0.00	5.00	15.32	2.95	PVC	10.3	12	0.0033	774.07	774.06	0.00	3.76	0.00	0.22	Begin Line	1.25	0.27	773.40	773.36	
STRM-1.5	0+24.19	0+20.79	3.40	0.0400	R-32	0.05	0.42	0.97	0.05	0.24	5.00	0.01	5.02	15.31	3.67	PVC	10.3	12	0.0051	773.89	773.87	3.76	4.68	0.22	0.34	45 Wye	0.75	0.17	773.36	773.22	
STRM-1.5	0+20.79	0+00.00	20.79	0.0400	R-33	0.06	0.48	0.97	0.06	0.30	5.02	0.06	5.08	15.30	4.53	PVC	10.3	12	0.0078	773.69	0.00	4.68	5.77	0.34	0.52	45 Bend	0.35	0.18	773.22	772.39	
STRM-2	3+04.40	2+96.43	7.97	0.0100	DA-14,DA-15,R42-R48	0.46	0.46	0.74	0.35	0.35	5.00	0.04	5.04	15.32	5.3	HDPE	12.4	18	0.0018	774.60	774.58	0.00	2.99	0.00	0.14	Begin Line	1.25	0.17	773.87	773.79	
STRM-2	2+96.43	2+29.83	66.60	0.0100	None	0.00	0.46	0.00	0.00	0.35	5.04	0.37	5.42	15.28	5.3	HDPE	12.4	18	0.0018	774.48	773.96	2.99	2.99	0.14	0.14	45 Bend	0.35	0.10	773.79	773.13	
STRM-2	2+29.83	1+72.56	57.27	0.0100	R-41	0.05	0.51	0.97	0.05	0.39	5.42	0.29	5.70	14.97																	

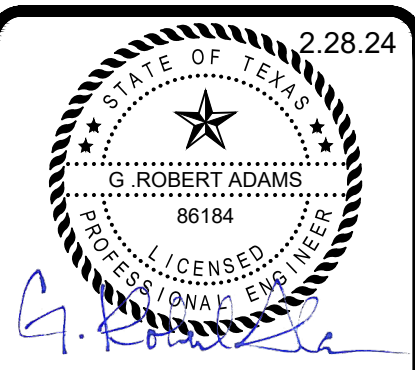

HYDRAULIC CALCULATIONS

Line ID	Upstream Station	Downstream Station	Pipe Length (ft)	Pipe Slope (ft/R)	Drainage Area Designation	Incremental Drainage Area (ac)	Cumulative Drainage Area (ac)	Runoff Coefficient "C"	Incremental "CA"	Cumulative "CA"	Time at Inlet (min)	Time in Pipe (min)	Cumulative Time (min)	Rainfall Intensity (in/hr)	Peak Flow (cfs)	Pipe Material	Pipe Capacity (cfs)	Pipe Diameter (in)	Friction Slope (ft/ft)	Hydraulic Gradient		Velocity In (ft/sec)	Velocity Out (ft/sec)	V1*2/2g (ft)	V2*2/2g (ft)	Upstream Junction Type	Loss Coefficient "K"	Velocity Head Loss (ft)	Upstream Invert Elev. (ft)	Downstream Invert Elev. (ft)	Comments
																				Upstream	Downstream										
STRM-4.1	0+38.83	0+33.17	5.66	0.0800	R-12	0.06	0.06	0.97	0.06	0.06	5.00	0.04	5.04	15.32	0.88	PVC	4.9	8	0.0025	777.45	777.44	0.00	2.52	0.00	0.10	Begin Line	1.25	0.12	777.23	776.77	
STRM-4.1	0+33.17	0+30.35	2.82	0.0800	DA-1	0.01	0.07	0.97	0.01	0.07	5.04	0.02	5.05	15.29	1.04	PVC	4.9	8	0.0036	777.22	777.21	2.52	2.99	0.10	0.14	45 Wye	0.75	0.10	776.77	776.55	
STRM-4.1	0+30.35	0+21.13	9.22	0.0800	None	0.00	0.07	0.00	0.00	0.07	5.05	0.05	5.10	15.27	1.04	PVC	4.9	8	0.0036	776.76	776.48	2.99	2.99	0.14	0.14	45 Bend	0.35	0.10	776.55	775.81	
STRM-4.1	0+21.13	0+09.65	11.48	0.0800	R-11	0.04	0.11	0.97	0.04	0.11	5.10	0.04	5.15	15.23	1.61	PVC	4.9	8	0.0085	776.08	775.56	2.99	4.62	0.14	0.33	45 Wye	0.75	0.23	775.81	774.89	
STRM-4.1	0+09.65	0+05.66	3.99	0.0800	R-10	0.01	0.12	0.97	0.01	0.12	5.15	0.01	5.16	15.19	1.80	PVC	4.9	8	0.0106	775.28	775.24	4.62	5.16	0.33	0.41	45 Wye	0.75	0.16	774.89	774.57	
STRM-4.1	0+05.66	0+00.00	5.66	0.0800	None	0.00	0.12	0.00	0.00	0.12	5.16	0.02	5.18	15.18	1.80	PVC	4.9	8	0.0106	774.85	774.79	5.16	5.16	0.41	0.41	45 Wye	0.75	0.10	774.57	774.12	
STRM-4.2	0+61.96	0+55.19	6.77	0.0100	G-1	0.89	0.89	0.97	0.86	0.86	5.00	0.02	5.02	15.32	13.21	PVC	15.2	18	0.0076	775.58	775.53	0.00	7.48	0.00	0.87	Begin Line	1.25	1.09	774.10	774.03	
STRM-4.2	0+55.19	0+45.62	9.57	0.0100	R-7	0.04	0.93	0.97	0.04	0.90	5.02	0.02	5.04	15.31	13.79	PVC	15.2	18	0.0083	775.93	775.85	7.48	7.81	0.87	0.95	45 Wye	0.75	0.30	774.44	774.35	
STRM-4.2	0+45.62	0+37.95	7.67	0.0100	R6, DA-21	0.04	0.97	0.87	0.04	0.94	5.02	0.02	5.05	15.29	14.37	PVC	15.2	18	0.0090	775.84	775.77	7.81	8.14	0.95	1.03	45 Wye	0.75	0.32	774.35	774.27	
STRM-4.2	0+37.95	0+32.49	5.46	0.0100	R-8	0.03	1.01	0.97	0.03	0.97	5.05	0.01	5.06	15.27	14.84	PVC	15.2	18	0.0096	775.77	775.71	8.14	8.40	1.03	1.10	45 Wye	0.75	0.32	774.27	774.21	
STRM-4.2	0+32.49	0+28.98	3.51	0.0100	R-5	0.03	1.03	0.97	0.03	1.00	5.06	0.01	5.07	15.27	15.24	PVC	15.2	18	0.0101	775.72	775.68	8.40	8.63	1.10	1.16	45 Wye	0.75	0.33	774.21	774.18	
STRM-4.2	0+28.98	0+24.75	4.23	0.0100	DA-20	0.02	1.05	0.51	0.01	1.01	5.07	0.01	5.08	15.26	15.38	PVC	15.2	18	0.0103	775.68	775.64	8.63	8.71	1.16	1.18	45 Wye	0.75	0.31	774.18	774.14	
STRM-4.2	0+24.75	0+12.94	11.81	0.0100	None	0.00	1.05	0.00	0.00	1.01	5.08	0.02	5.10	15.25	15.37	PVC	15.2	18	0.0103	775.64	775.52	8.71	8.70	1.18	1.18	45 Bend	0.35	0.41	774.14	774.02	
STRM-4.2	0+12.94	0+00.00	12.94	0.0100	R-9	0.01	1.07	0.97	0.01	1.02	5.10	0.02	5.12	15.23	15.56	PVC	15.2	18	0.0105	775.53	775.39	8.70	8.81	1.18	1.21	45 Wye	0.75	0.32	774.02	773.89	
STRM-4.2.1	0+08.09	0+04.71	3.38	0.0900	DA-20	0.02	0.02	0.51	0.01	0.01	0.00	0.09	0.09	22.05	0.22	HDPE	4.3	8	0.0002	775.92	775.92	0.00	0.62	0.00	0.01	Begin Line	1.25	0.10	775.56	775.25	
STRM-4.2.1	0+04.71	0+00.00	4.71	0.0900	None	0.00	0.02	0.00	0.00	0.01	0.09	0.13	0.22	21.86	0.21	HDPE	4.3	8	0.0002	775.36	0.00	0.62	0.61	0.01	0.01	45 Bend	0.35	0.10	775.25	774.83	
STRM-4.2.2	0+08.01	0+04.24	3.77	0.0900	R6, DA-21	0.04	0.04	0.87	0.04	0.04	0.00	0.03	0.03	22.05	0.86	HDPE	4.3	8	0.0036	775.89	775.88	0.00	2.47	0.00	0.09	Begin Line	1.25	0.12	775.55	775.21	
STRM-4.2.2	0+04.24	0+00.00	4.24	0.0900	None	0.00	0.04	0.00	0.00	0.04	0.03	0.03	0.05	22.00	0.86	HDPE	4.3	8	0.0036	775.42	0.00	2.47	2.46	0.09	0.09	45 Bend	0.35	0.10	775.21	774.83	
STRM-4.3	0+11.36	0+00.00	11.36	0.1000	DA-19	0.09	0.09	0.84	0.07	0.07	0.00	0.09	0.09	22.05	1.61	HDPE	13.3	12	0.0015	775.58	775.20	0.00	2.05	0.00	0.07	Begin Line	1.25	0.10	775.34	774.20	
STRM-4.4	0+06.98	0+04.64	2.34	0.0100	R-49-59 CY-1	0.49	0.49	0.91	0.45	0.45	0.00	0.01	0.01	22.05	9.87	HDPE	12.4	18	0.0063	778.19	778.18	0.00	5.59	0.00	0.48	Begin Line	1.25	0.61	777.01	776.99	
STRM-4.4	0+04.64	0+00.00	4.64	0.0100	None	0.00	0.49	0.00	0.00	0.45	0.01	0.01	0.02	22.04	9.86	HDPE	12.4	18	0.0063	778.01	0.00	5.59	5.58	0.48	0.48	45 Bend	0.35	0.17	776.99	776.94	
STRM-5	4+30.51	4+07.39	23.12	0.0133	On-site	6.58	6.58	0.90	5.90	5.90	0.00	0.03	0.03	22.05	90.35	HDPE	90.9	36	0.0131	773.10	772.80	0.00	12.79	0.00	2.54	Begin Line	1.25	3.17	768.89	768.58	
STRM-5	4+07.39	2+72.17	135.22	0.0133	None	0.00	6.58	0.00	0.00	5.90	0.03	0.18	0.21	21.99	90.35	HDPE	90.9	36	0.0131	771.91	770.13	12.79	12.79	2.54	2.54	45 Bend	0.35	0.89	768.58	766.78	
STRM-5	2+72.17	0+39.58	232.59	0.0133	None	0.00	6.58	0.00	0.00	5.90	0.21	0.30	0.51	21.62	90.35	HDPE	90.9	36	0.0131	770.03	766.98	12.79	12.79	2.54	2.54	MH	1.00	0.10	766.78	763.69	
STRM-5	0+39.58	0+00.00	39.58	0.0139	None	0.00	6.58	0.00	0.00	5.90	0.51	0.05	0.56	21.02	90.35	HDPE	92.9	36	0.0131	766.09	0.00	12.79	12.79	2.54	2.54	45 Bend	0.35	0.89	763.69	763.14	
STRM-05	5+43.32	2+75.18	268.14	0.0150	On-site	6.58	6.58	0.90	5.90	5.90	0.00	0.35	0.35	22.05	90.35	HDPE	96.5	36	0.0131	774.72	771.20	0.00	12.79	0.00	2.54	Begin Line	1.25	3.17	7.79	3.76	
STRM-05	2+75.18	0+24.23	250.95	0.0150	SS-1	6.74	13.32	0.86	5.76	11.66	0.35	0.33	0.68	21.33	248.65	HDPE	377.0	60	0.0065	771.10	769.46	12.79	12.67	2.54	2.49	MH	1.00	0.10	3.76	0.00	
STRM-05	0+24.23	0+00.00	24.23	0.0150	SS-2	5.65	18.97	0.86	4.83	16.49	0.68	0.02	0.70	20.70	341.39	HDPE	377.0	60	0.0123	767.25	0.00	12.67	17.40	2.49	4.70	MH	1.00	2.21	763.50	763.14	

CURB INLET SUMMARY (100-YR DESIGN)

INLET ID	Drainage Area	Contributing Flow	Upstream Carryover	Design Flow	Inlet Length	Depth of Opening	Ponding Depth	Inlet Capacity	Captured Flow	Overflow
-	-	(cfs)	(cfs)	(cfs)	(ft)	(ft)	(ft)	(ft)	(cfs)	(cfs)
CI-1	DA-2	2.68	0.00	2.68	5.00	0.92	0.32	13.24	2.68	0.00
CI-2	DA-4	1.62	0.00	1.62	5.00	0.92	0.23	13.24	1.62	0.00
CI-3	DA-5	1.42	0.00	1.42	5.00	0.92	0.21	13.24	1.42	0.00
CI-4	DA-6	2.79	0.00	2.79	5.00	0.92	0.33	13.24	2.79	0.00
CI-5	DA-7	2.14	0.00	2.14	5.00	0.92	0.27	13.24	2.14	0.00
CI-6	DA-8	2.60	0.00	2.60	5.00	0.92	0.31	13.24	2.60	0.00
CI-7	DA-9	3.92	0.00	3.92	5.00	0.92	0.41	13.24	3.92	0.00
CI-8	DA-10	2.84	0.00	2.84	5.00	0.92	0.33	13.24	2.84	0.00
CI-9	DA-14	0.67	0.00	0.67	5.00	0.92	0.13	13.24	0.67	0.00
CI-10	DA-19	1.12	0.00	1.12	5.00	0.92	0.18	13.24	1.12	0.00

GRATE INLET SUMMARY (100-YR DESIGN)

INLET ID	Drainage Area	Contributing Flow	Upstream Carryover	Design Flow	Grate Open Area	Ponding Depth	Max. Ponding Depth	Inlet Capacity	Captured Flow	Overflow
-	-	(cfs)	(cfs)	(cfs)	(sf)	(ft)	(ft)	(cfs)	(cfs)	(cfs)
GI-1	DA-1	0.16	0.00	0.16	0.58	0.00	0.50	1.97	0.16	0.00
GI-2	DA-3	0.04	0.00	0.04	0.58	0.00	0.50	1.97	0.04	0.00
GI-3	DA-11	2.23	0.00	2.23	2.40	0.04	0.50	8.17	2.23	0.00
GI-4	DA-12	1.99	0.00	1.99	0.59	0.49	0.50	2.01	1.99	0.00
GI-5	DA-13	2.11	0.00	2.11	1.70	0.07	0.50	5.79	2.11	0.00
GI-6	DA-15	1.75	0.00	1.75	0.58	0.39	0.50	1.97	1.75	0.00
GI-7	DA-16	0.28								

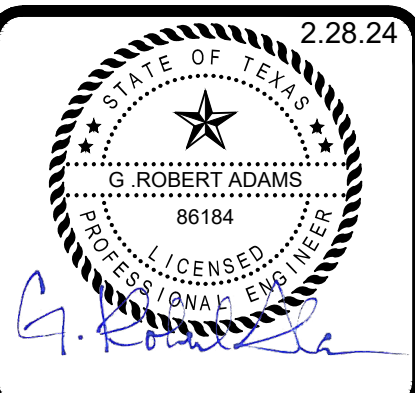

REVISIONS

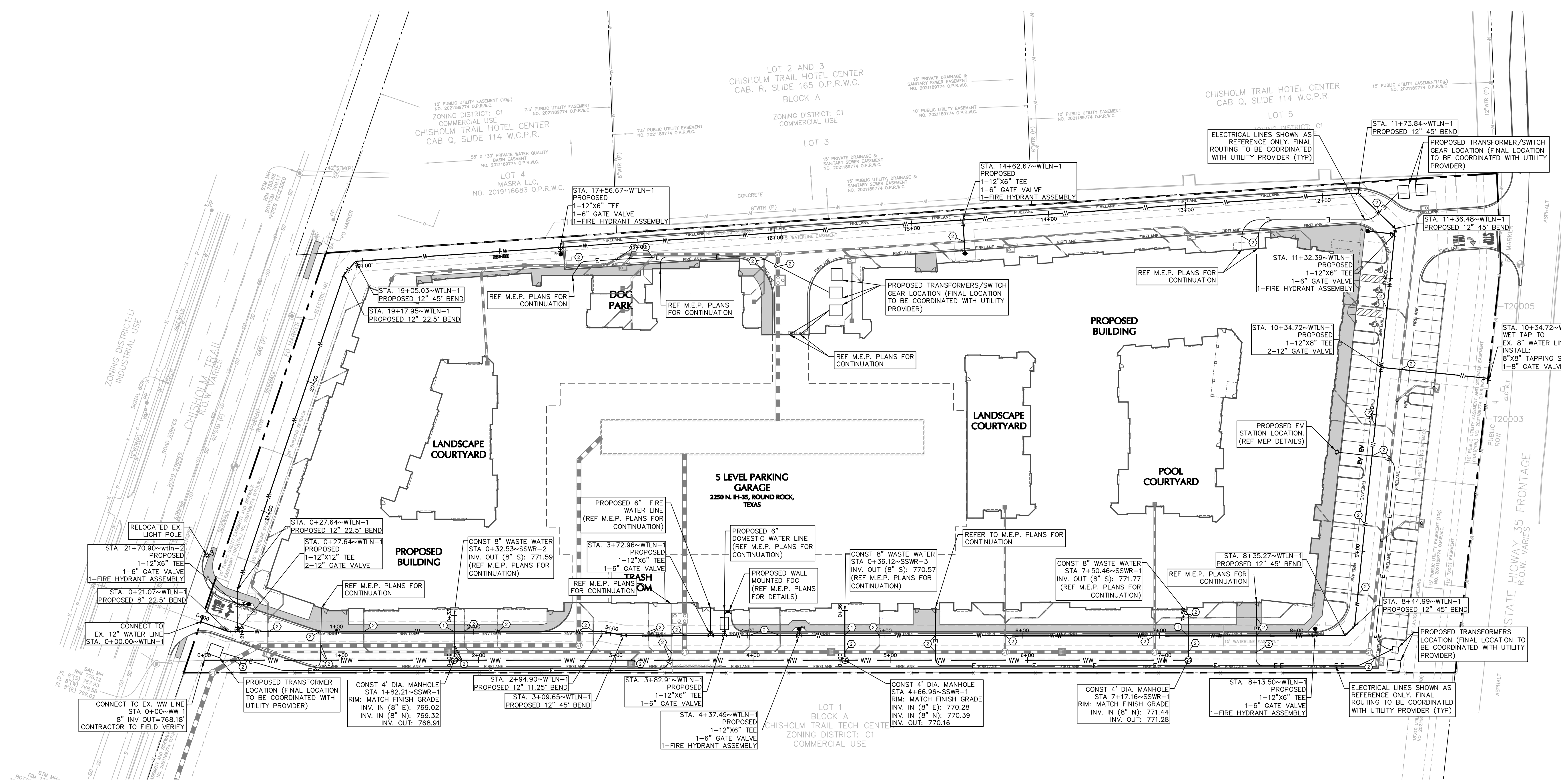

JADE AT CHISHOLM TRAIL
392 APARTMENT UNITS IN ROUND ROCK, TEXAS
GLENRIDGE DEVELOPMENT

PERMIT SET
ISSUED 02-28-2024

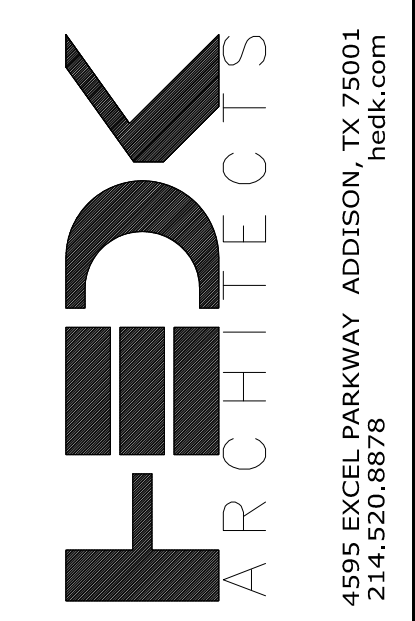

DATE
02-28-2024

PROJECT
22137

SHEET NUMBER
C7.00

UTILITY PLAN

WATER AND SEWER GENERAL NOTES

- ALL WATER MAINS UNLESS OTHERWISE NOTED SHALL HAVE A MINIMUM COVER OF 48" BELOW FINISHED GRADE. PROVIDE VALVE EXTENSIONS TO ALL VALVES ON LINES DEEPER THAN 48".
- WHEN WATER MAINS AND SANITARY SEWERS ARE INSTALLED, THEY SHALL BE INSTALLED NO CLOSER TO EACH OTHER THAN NINE FEET IN ALL DIRECTIONS, AND PARALLEL LINES MUST BE INSTALLED IN SEPARATE TRENCHES. WHERE THE NINE FOOT SEPARATION DISTANCE CANNOT BE ACHIEVED, THE FOLLOWING GUIDELINES SHALL APPLY:
 - WHERE A SANITARY SEWER PARALLELS A WATERLINE, THE SEWER SHALL BE CONSTRUCTED OF CAST IRON, DUCTILE IRON, OR PVC MEETING ASTM SPECIFICATIONS WITH A PRESSURE RATING FOR BOTH THE PIPE AND JOINTS OF 150 PSI. THE VERTICAL SEPARATION SHALL BE A MINIMUM OF TWO FEET BETWEEN OUTSIDE DIAMETERS, AND THE HORIZONTAL SEPARATION SHALL BE A MINIMUM OF FOUR FEET BETWEEN OUTSIDE DIAMETERS. THE SEWER SHALL BE LOCATED BELOW THE WATERLINE.
 - WHERE A SANITARY SEWER CROSSES A WATERLINE AND THE SEWER IS CONSTRUCTED OF CAST IRON, DUCTILE IRON OR PVC WITH A MINIMUM PRESSURE RATING OF 150 PSI, AN ABSOLUTE MINIMUM DISTANCE OF SIX INCHES BETWEEN OUTSIDE DIAMETERS SHALL BE MAINTAINED. IN ADDITION, THE SEWER SHALL BE LOCATED BELOW THE WATERLINE WHERE POSSIBLE AND ONE LENGTH OF THE SEWER PIPE MUST BE CENTERED ON THE WATERLINE.
 - WHERE A SEWER CROSSES UNDER A WATERLINE AND THE SEWER IS CONSTRUCTED OF ABS TRUSS PIPE, SIMILAR SEMI-RIGID PLASTIC COMPOSITE PIPE, CLAY PIPE OR CONCRETE PIPE WITH GASKETED JOINTS, A MINIMUM TWO FOOT SEPARATION DISTANCE SHALL BE MAINTAINED. IN ADDITION, THE SEWER SHALL BE LOCATED BELOW THE WATERLINE WHERE POSSIBLE AND ONE LENGTH OF THE SEWER PIPE MUST BE CENTERED ON THE WATERLINE.
 - WHERE A SEWER CROSSES OVER A WATERLINE, ALL PORTIONS OF THE SEWER WITHIN NINE FEET OF THE WATERLINE SHALL BE CONSTRUCTED OF CAST IRON, DUCTILE IRON OR PVC PIPE WITH A PROCEDURE, THE NEW CONVEYANCE MAY BE ENCASED IN A JOINT OF 150 PSI PRESSURE CLASS PIPE AT LEAST 18 FEET LONG AND TWO NOMINAL SIZES LARGER THAN THE NEW CONVEYANCE. THE SPACE AROUND THE CARRIER PIPE SHALL BE SUPPORTED AT FIVE FEET INTERVALS WITH SPACERS OR BE FILLED TO THE SPRING LINE WITH WASHED SAND. THE ENCASEMENT PIPE SHOULD BE CENTERED ON THE CROSSING AND BOTH ENDS SEALED WITH CEMENT GROUT OR MANUFACTURED SEAL.
 - THE SEWER NEED NOT BE DISTURBED WHERE A NEW WATERLINE IS TO BE INSTALLED PARALLEL TO AN EXISTING SEWER THAT SHOWS NO EVIDENCE OF LEAKAGE AND THE WATERLINE IS INSTALLED ABOVE THE SEWER A MINIMUM OF TWO FEET VERTICALLY AND FOUR FEET HORIZONTALLY. SHOULD EXCAVATION FOR THE WATERLINE PRODUCE EVIDENCE THAT THE SEWER IS LEAKING, THE SEWER MUST BE REPAIRED OR REPLACED AS DESCRIBED IN SUBPARAGRAPHS (A) OR (D) OF THIS PARAGRAPH.
 - THE SEWER NEED NOT BE DISTURBED WHERE A NEW WATERLINE IS TO CROSS OVER (BY TWO FEET OR MORE) EXISTING SEWER SHOWING NO EVIDENCE OF LEAKAGE. SHOULD EXCAVATION FOR THE WATERLINE PRODUCE EVIDENCE THAT THE SEWER IS LEAKING, THEN THE SEWER MUST BE REPAIRED OR REPLACED AS DESCRIBED IN SUBSECTIONS (C) OR (D).
- CONTRACTOR TO VERIFY ALL EXISTING SEWER FLOW LINES BEFORE BEGINNING CONSTRUCTION.
- ALL SANITARY SEWER LINES SHALL BE TESTED IN ACCORDANCE WITH THE STANDARD CITY SPECIFICATIONS.
- THE UTILITY CONTRACTOR SHALL INSTALL THE WATER SERVICES TO A POINT AS SHOWN ON THE PLANS. THE METER BOX SHALL BE FURNISHED AND INSTALLED BY THE CONTRACTOR AFTER THE PAVING CONTRACTOR HAS COMPLETED THE FINE GRADING BEHIND THE BACK OF THE CURB. EACH SERVICE LOCATION WILL BE MARKED ON THE CURB, WITH A BLUE LETTER "W" BY THE UTILITY CONTRACTOR AND TIED TO PROPERTY CORNERS ON THE "RECORD DRAWINGS".
- ALL METER BOXES SHALL BE LOCATED IN NON-TRAFFIC AREAS.
- VALVE BOXES SHALL BE FURNISHED AND SET ON EACH GATE VALVE. AFTER THE FINAL CLEANUP AND ALIGNMENT HAS BEEN COMPLETED, THE CONTRACTOR (UTILITY) SHALL POUR A CONCRETE BLOCK 24"x24"x6" AROUND ALL VALVE BOX TOPS SO THAT THE TOP OF BOX IS LEVEL WITH THE FINISHED GRADE. MARK WITH F OR O OR S IN CONCRETE.
- CONTRACTOR SHALL RAISE/LOWER OR ADJUST ALL EXISTING UTILITY MAINS IN CONFLICT WITH PROPOSED UTILITIES AS PART OF THE BASE BIDS FOR ALL KNOWN OR UNKNOWN LINES.

**** NOTICE TO CONTRACTORS - TOPOGRAPHIC SURVEY ****

TOPOGRAPHIC INFORMATION TAKEN FROM A TOPOGRAPHIC SURVEY PERFORMED BY WINDROSE LAND SERVICES, LLC. THE CONTRACTOR SHALL NOTIFY THE ENGINEER IMMEDIATELY, IN WRITING, OF ANY DISCREPANCIES OR OMISSIONS TO THE TOPOGRAPHIC INFORMATION. THE CONTRACTOR(S) SHALL BE RESPONSIBLE FOR CONFIRMING THE LOCATION (HORIZONTAL/VERTICAL) OF ANY BURIED CABLES, CONDUITS, PIPES, AND STRUCTURES (STORM SEWER, SANITARY SEWER, WATER, GAS, TELEVISION, TELEPHONE, ETC.) WHICH IMPACT THE CONSTRUCTION SITE. THE CONTRACTOR(S) SHALL NOTIFY THE OWNER AND ENGINEER IF ANY DISCREPANCIES ARE FOUND BETWEEN THE ACTUAL CONDITIONS VERSUS THE DATA CONTAINED IN THE CONSTRUCTION PLANS. ANY COSTS INCURRED AS THE RESULT OF NOT CONFIRMING THE ACTUAL LOCATION (HORIZONTAL/VERTICAL) OF SAID CABLES, CONDUITS, PIPES, AND STRUCTURES SHALL BE BORNE BY THE CONTRACTOR. ADDITIONALLY, THE CONTRACTOR(S) SHALL NOTIFY THE OWNER AND ENGINEER IF ANY ERRORS OR DISCREPANCIES ARE FOUND ON THE CONSTRUCTION DOCUMENTS (PS&E), WHICH NEGATIVELY IMPACT THE PROJECT. THE ENGINEER AND OWNER SHALL BE INDEMNIFIED OF PROBLEMS AND/OR COST WHICH MAY RESULT FROM CONTRACTOR'S FAILURE TO NOTIFY ENGINEER AND OWNER.

****NOTICE TO CONTRACTORS - UTILITIES****

THE CONTRACTOR IS SPECIFICALLY CAUTIONED THAT THE LOCATION AND/OR ELEVATION OF ANY EXISTING UTILITIES AS SHOWN ON THESE PLANS ARE BASED ON RECORDS OF THE VARIOUS UTILITY COMPANIES, THE GOVERNING MUNICIPALITY, AND WHERE POSSIBLE, MEASUREMENTS TAKEN IN THE FIELD. THE INFORMATION PROVIDED IS NOT TO BE RELIED ON AS BEING EXACT OR COMPLETE. THE CONTRACTOR MUST CALL THE APPROPRIATE UTILITY COMPANY AT LEAST 48 HOURS BEFORE ANY EXCAVATION TO REQUEST EXACT FIELD LOCATION OF UTILITIES. IT SHALL BE THE RESPONSIBILITY OF THE CONTRACTOR TO RELOCATE ALL EXISTING UTILITIES WHICH CONFLICT WITH THE PROPOSED IMPROVEMENTS SHOWN ON THESE PLANS.



THESE PLANS ARE SUBJECT TO REVIEW & APPROVAL BY JURISDICTIONAL ENTITIES.

LEGEND

- EXISTING SANITARY SEWER LINE
- PROPOSED SANITARY SEWER LINE
- EXISTING WATER LINE
- PROPOSED WATER LINE
- PROPOSED STORM SEWER LINE
- PROPOSED SANITARY MANHOLE
- PROPOSED FIRE HYDRANT
- WALL MOUNTED FDC
- PROPOSED STORM MANHOLE

SYMBOL KEY

- ① WATER-SANITARY SEWER CROSSING PER CITY AND TCEQ STANDARDS
- ② UTILITY CROSSING



LANGAN

Langan Engineering and Environmental Services, Inc.
9606 N. Mopac Expressway, Suite 110
Austin, TX 78759
T: 737.289.7800 F: 737.289.7801 www.langan.com
TBP# FIRM REG. #F-13709

CoRR Tracking Number : SDP23-00054

COPYRIGHT © HEDK Architects ALL RIGHTS RESERVED

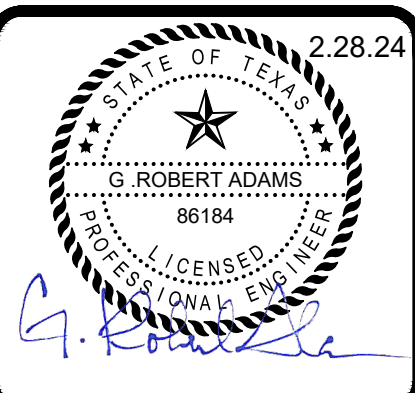

REVISIONS

NO.	DATE	DESCRIPTION

JADE AT CHISHOLM TRAIL
 392 APARTMENT UNITS IN ROUND ROCK, TEXAS
 GLENRIDGE DEVELOPMENT

PERMIT SET
 ISSUED 02-28-2024

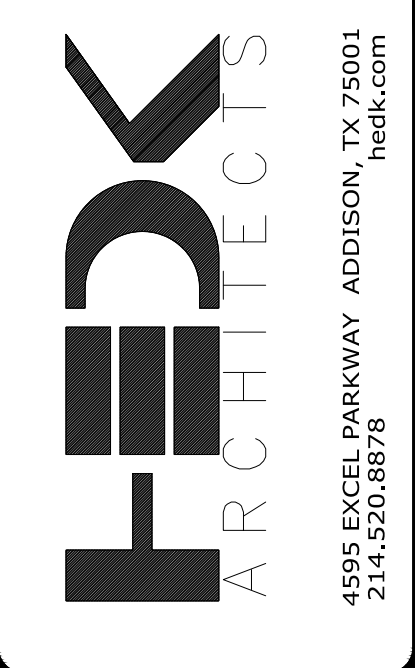

DATE
 02-28-2024

PROJECT
 22137

SHEET NUMBER
C7.02

WATER PROFILE

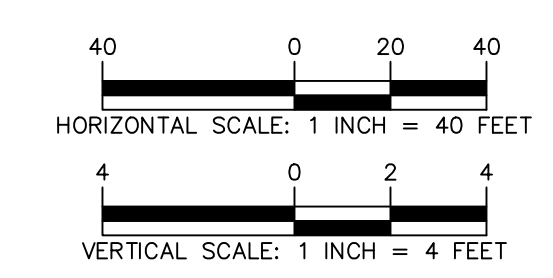
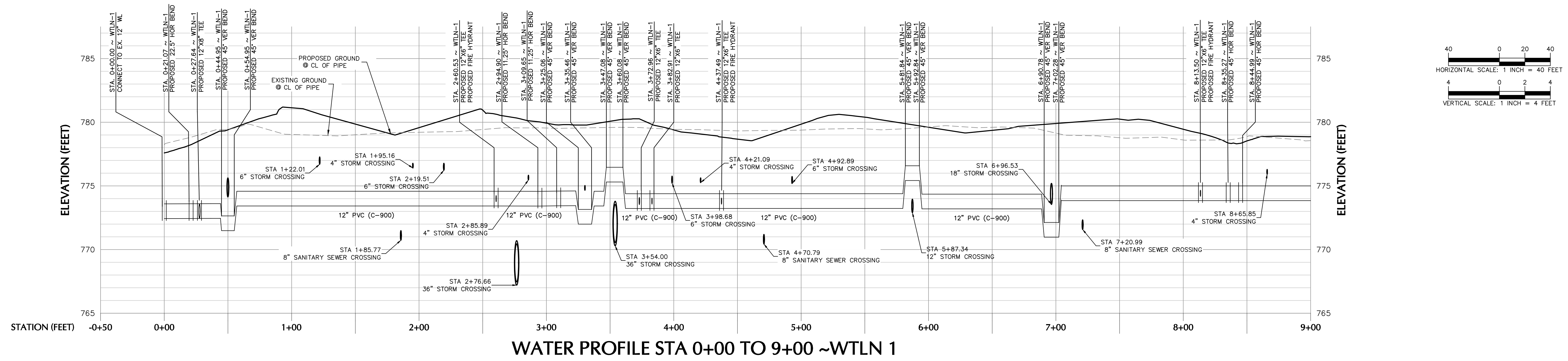

WATER PROFILE STA 0+00 TO 9+00 ~WTLN 1

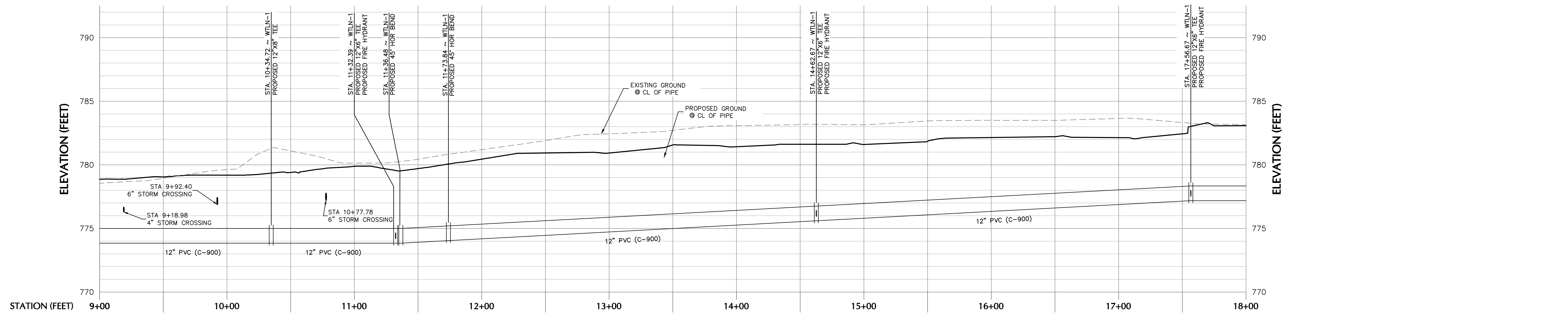

WATER PROFILE STA 9+00 TO 18+00 ~WTLN 1

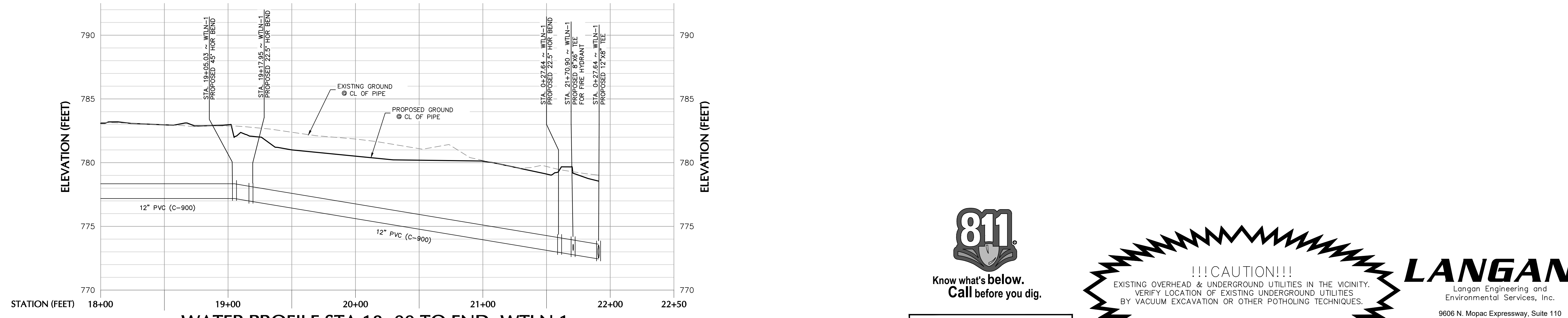

WATER PROFILE STA 18+00 TO END ~WTLN 1



THESE PLANS ARE SUBJECT TO REVIEW & APPROVAL BY JURISDICTIONAL ENTITIES.



9606 N. Mopac Expressway, Suite 110
 Austin, TX 78759
 T: 737.289.7800 F: 737.289.7801 www.langan.com
 TBPE FIRM REG. #F-13709

CoRR Tracking Number : SDP23-00054

COPYRIGHT © HEDK ARCHITECTS ALL RIGHTS RESERVED

- ALL TREES NOT LOCATED WITHIN THE LIMITS OF CONSTRUCTION AND OUTSIDE OF DISTURBED AREAS SHALL BE PRESERVED. THE CONTRACTOR IS RESPONSIBLE FOR PROTECTING ALL TREES TO BE PRESERVED FROM HIS ACTIVITIES.
- ALL TREES SHOWN TO BE RETAINED ON THE PLANS, SHALL BE PROTECTED DURING CONSTRUCTION WITH FENCING. SEE: TREE PROTECTION TREE WELLS (EC-02), TREE PROTECTION TREE LOCATION (EC-03) AND TREE PROTECTION FENCE-CHAIN LINK (EC-04).
- TREE PROTECTION FENCES SHALL BE ERECTED ACCORDING TO CITY STANDARDS FOR TREE PROTECTION, INCLUDING TYPES OF FENCING AND SIGNAGE.
- TREE PROTECTION FENCES SHALL BE INSTALLED PRIOR TO THE COMMENCEMENT OF ANY SITE PREPARATION WORK (CLEARING, GRUBBING, OR GRADING) AND SHALL BE MAINTAINED THROUGHOUT ALL PHASES OF THE CONSTRUCTION PROJECT.
- EROSION AND SEDIMENTATION CONTROL BARRIERS SHALL BE INSTALLED OR MAINTAINED IN A MANNER WHICH DOES NOT RESULT IN SOIL BUILD-UP WITHIN TREE DRILINES.
- FENCES SHALL COMPLETELY SURROUND THE TREE, OR CLUSTERS OF TREES, LOCATED AT THE OUTERMOST LIMITS OF THE TREE BRANCHES (DRIFLINE) OR CRITICAL ROOT ZONE (CRZ), WHICHEVER IS GREATER, AND SHALL BE MAINTAINED THROUGHOUT THE CONSTRUCTION PROJECT IN ORDER TO PREVENT THE FOLLOWING:
 - SOIL COMPACTION IN CRZ AREA RESULTING FROM VEHICULAR TRAFFIC OR STORAGE OF EQUIPMENT OR MATERIAL.
 - CRZ DISTURBANCES DUE TO GRADE CHANGES (GREATER THAN 6 INCHES CUT OR FILL) OR TRENCHING NOT REVIEWED AND AUTHORIZED BY THE FORESTRY MANAGER.
 - WOUNDS TO EXPOSED ROOTS, TRUNK, OR LIMBS BY MECHANICAL EQUIPMENT.
 - OTHER ACTIVITIES DETRIMENTAL TO TREES SUCH AS CHEMICAL STORAGE, CONCRETE TRUCK CLEANING, AND FIRES.
- EXCEPTIONS TO INSTALLING TREE FENCES AT THE TREE DRILINES OR CRZ, WHICHEVER IS GREATER, MAY BE PERMITTED IN THE FOLLOWING CASES:
 - WHERE THERE IS TO BE AN APPROVED GRADE CHANGE, IMPERMEABLE PAVING SURFACE, OR TREE WELL.
 - WHERE PERMEABLE PAVING IS TO BE INSTALLED, ERECT THE FENCE AT THE OUTER LIMITS OF THE PERMEABLE PAVING AREA.
 - WHERE TREES ARE CLOSE TO PROPOSED BUILDINGS, ERECT THE FENCE NO CLOSER THAN 6 FEET TO THE BUILDING.
 - WHERE THERE ARE SEVERE SPACE CONSTRAINTS DUE TO TRACT SIZE, OR OTHER SPECIAL REQUIREMENTS, CONTACT THE FORESTRY MANAGER TO DISCUSS ALTERNATIVES.
- WHERE ANY OF THE ABOVE EXCEPTIONS RESULT IN A FENCE THAT IS CLOSER THAN 5 FEET TO A TREE TRUNK, THE TRUNK SHALL BE PROTECTED BY STRAPPED-ON PLANKING TO A HEIGHT OF 8 FEET (OR TO THE LIMITS OF LOWER BRANCHING) IN ADDITION TO THE REDUCED FENCING PROVIDED.
- WHERE ANY OF THE ABOVE EXCEPTIONS RESULT IN AREAS OF UNPROTECTED ROOT ZONES UNDER THE DRIFLINE OR CRZ, WHICHEVER IS GREATER, THOSE AREAS SHOULD BE COVERED WITH 4 INCHES OF ORGANIC MULCH TO MINIMIZE SOIL COMPACTION.
- ALL GRADING WITHIN CRZ AREAS SHALL BE DONE BY HAND OR WITH SMALL EQUIPMENT TO MINIMIZE ROOT DAMAGE. PRIOR TO GRADING, RELOCATE PROTECTIVE FENCING TO 2 FEET BEHIND THE GRADE CHANGE AREA.
- ANY ROOTS EXPOSED BY CONSTRUCTION ACTIVITY SHALL BE PRUNED FLUSH WITH THE SOIL AND BACKFILLED WITH GOOD QUALITY TOP SOIL WITHIN TWO DAYS. IF EXPOSED ROOT AREAS CANNOT BE BACKFILLED WITHIN 2 DAYS, AN ORGANIC MATERIAL WHICH REDUCES SOIL TEMPERATURE AND MINIMIZES WATER LOSS DUE TO EVAPORATION SHALL BE PLACED TO COVER THE ROOTS UNTIL BACKFILL CAN OCCUR.
- PRIOR TO EXCAVATION OR GRADE CUTTING WITHIN TREE DRILINES, A CLEAN CUT SHALL BE MADE BETWEEN THE DISTURBED AND UNDISTURBED ROOT ZONES WITH A ROCK SAW OR SIMILAR EQUIPMENT, IN A LOCATION AND TO A DEPTH APPROVED BY THE FORESTRY MANAGER, TO MINIMIZE DAMAGE TO REMAINING ROOTS.
- TREES MOST HEAVILY IMPACTED BY CONSTRUCTION ACTIVITIES WILL BE WATERED DEEPLY ONCE A WEEK DURING PERIODS OF HOT, DRY WEATHER. TREE CROWNS ARE TO BE SPRAYED WITH WATER PERIODICALLY TO REDUCE DUST ACCUMULATION ON LEAVES.
- WHEN INSTALLING CONCRETE ADJACENT TO THE ROOT ZONE OF A TREE, A PLASTIC VAPOR BARRIER SHALL BE PLACED BEHIND THE CONCRETE TO PROHIBIT LEACHING OF LIME INTO THE CRZ.
- ANY TRENCHING REQUIRED FOR THE INSTALLATION OF LANDSCAPE IRRIGATION SHALL BE PLACED AS FAR FROM EXISTING TREE TRUNKS AS POSSIBLE.
- NO LANDSCAPE TOPSOIL DRESSING GREATER THAN FOUR (4) INCHES SHALL BE PERMITTED WITHIN THE DRIFLINE OR CRZ OF TREES, WHICHEVER IS GREATER. NO TOPSOIL IS PERMITTED ON ROOT FLARES OF ANY TREE.
- PRUNING TO PROVIDE CLEARANCE FOR STRUCTURES, VEHICULAR TRAFFIC, AND CONSTRUCTION EQUIPMENT SHALL TAKE PLACE BEFORE CONSTRUCTION BEGINS. ALL PRUNING MUST BE DONE ACCORDING TO CITY STANDARDS AND AS OUTLINED IN LITERATURE PROVIDED BY THE INTERNATIONAL SOCIETY OF ARBORICULTURE (ISA PRUNING TECHNIQUES).
- ALL OAK TREE CUTS, INTENTIONAL OR UNINTENTIONAL, SHALL BE SEALED WITH AN APPROVED PRUNING SEALER IMMEDIATELY (WITHIN 10 MINUTES). PRUNING SEAL OR TREE PAINT MUST BE KEPT ON SITE AT ALL TIMES.
- THE FORESTRY MANAGER HAS THE AUTHORITY TO REQUIRE ADDITIONAL TREE PROTECTION BEFORE OR DURING CONSTRUCTION.
- TREES APPROVED FOR REMOVAL SHALL BE REMOVED IN A MANNER WHICH DOES NOT IMPACT TREES TO BE PRESERVED. REFER TO THE CITY OF ROUND ROCK TREE REMOVAL MANUAL FOR APPROPRIATE REMOVAL METHODS.
- PRIOR TO CONSTRUCTION, ALL LOWER TREE LIMBS OVER ROADWAYS MUST BE PRUNED TO A HEIGHT OF 14 FEET USING THE TECHNIQUES DESCRIBED IN THE CITY OF ROUND ROCK TREE TECHNICAL MANUAL.
- DEVIATIONS FROM THE ABOVE NOTES MAY BE CONSIDERED ORDINANCE VIOLATIONS IF THERE IS NON COMPLIANCE OR IF A TREE SUSTAINS DAMAGE AS A RESULT.

FOR QUESTIONS CONCERNING THIS DETAIL, PLEASE CONTACT THE FORESTRY MANAGER.

RECORD SIGNED COPY ON FILE APPROVED 01-28-21 DATE	CITY OF ROUND ROCK	DRAWING NO: EC-01 SHEET 1 of 1
TREE PROTECTION NOTES		
		

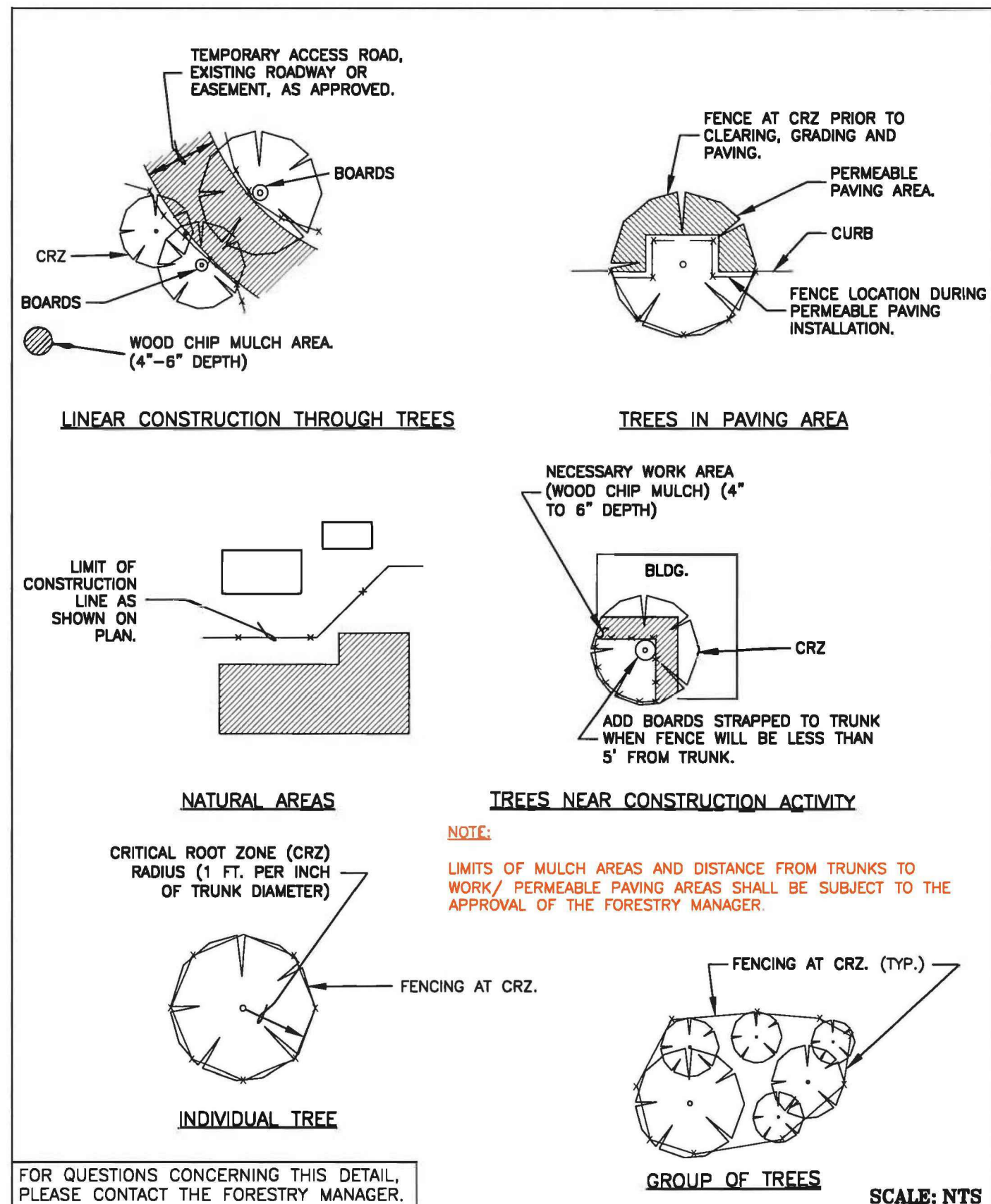

FOR QUESTIONS CONCERNING THIS DETAIL, PLEASE CONTACT THE FORESTRY MANAGER.

RECORD SIGNED COPY ON FILE APPROVED 01-28-21 DATE	CITY OF ROUND ROCK	DRAWING NO: EC-03 SHEET 1 of 1
TREE PROTECTION FENCE LOCATIONS		
		

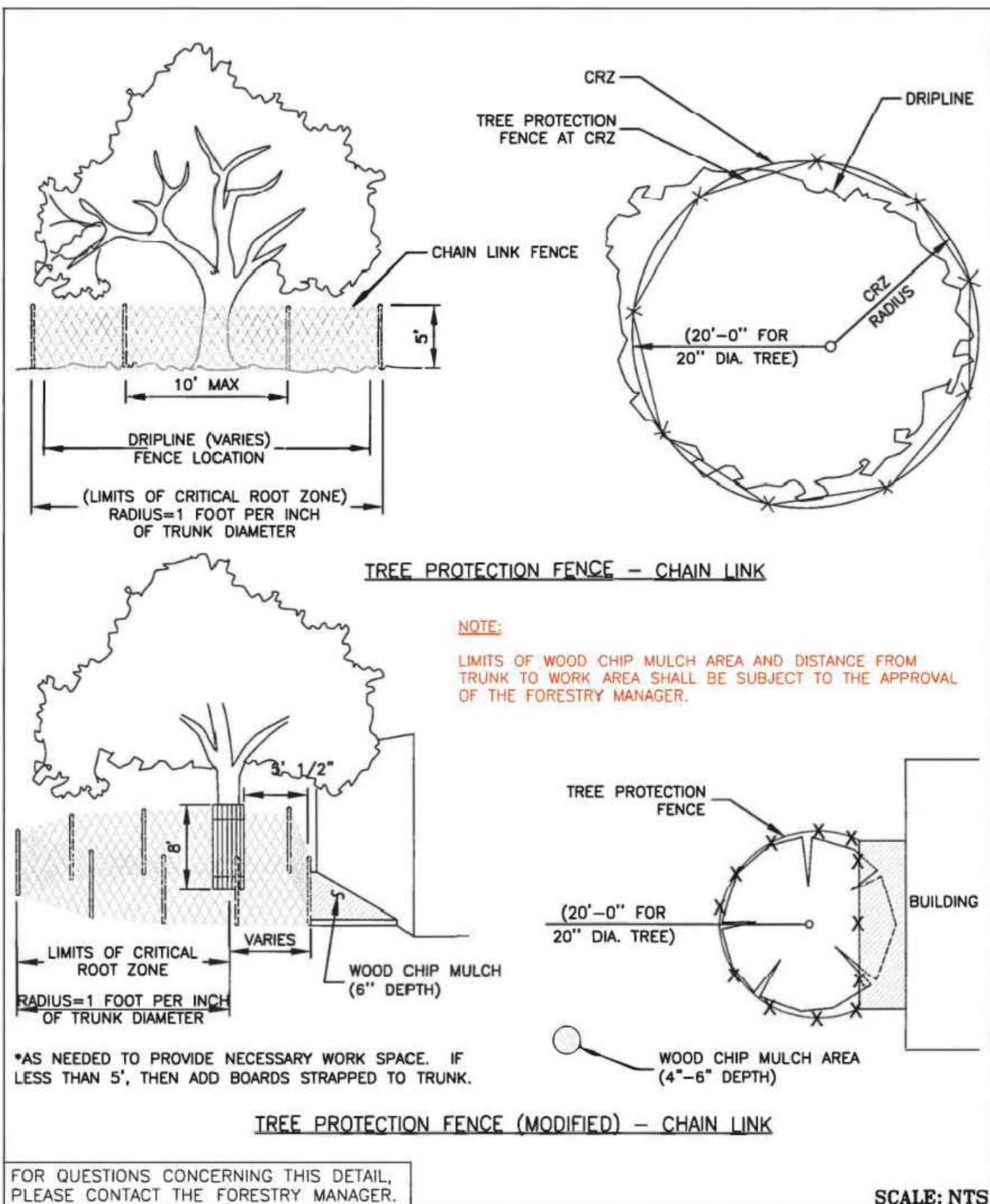

FOR QUESTIONS CONCERNING THIS DETAIL, PLEASE CONTACT THE FORESTRY MANAGER.

RECORD SIGNED COPY ON FILE APPROVED 01-28-21 DATE	CITY OF ROUND ROCK	DRAWING NO: EC-04 SHEET 1 of 1
TREE PROTECTION FENCE CHAIN LINK		
		

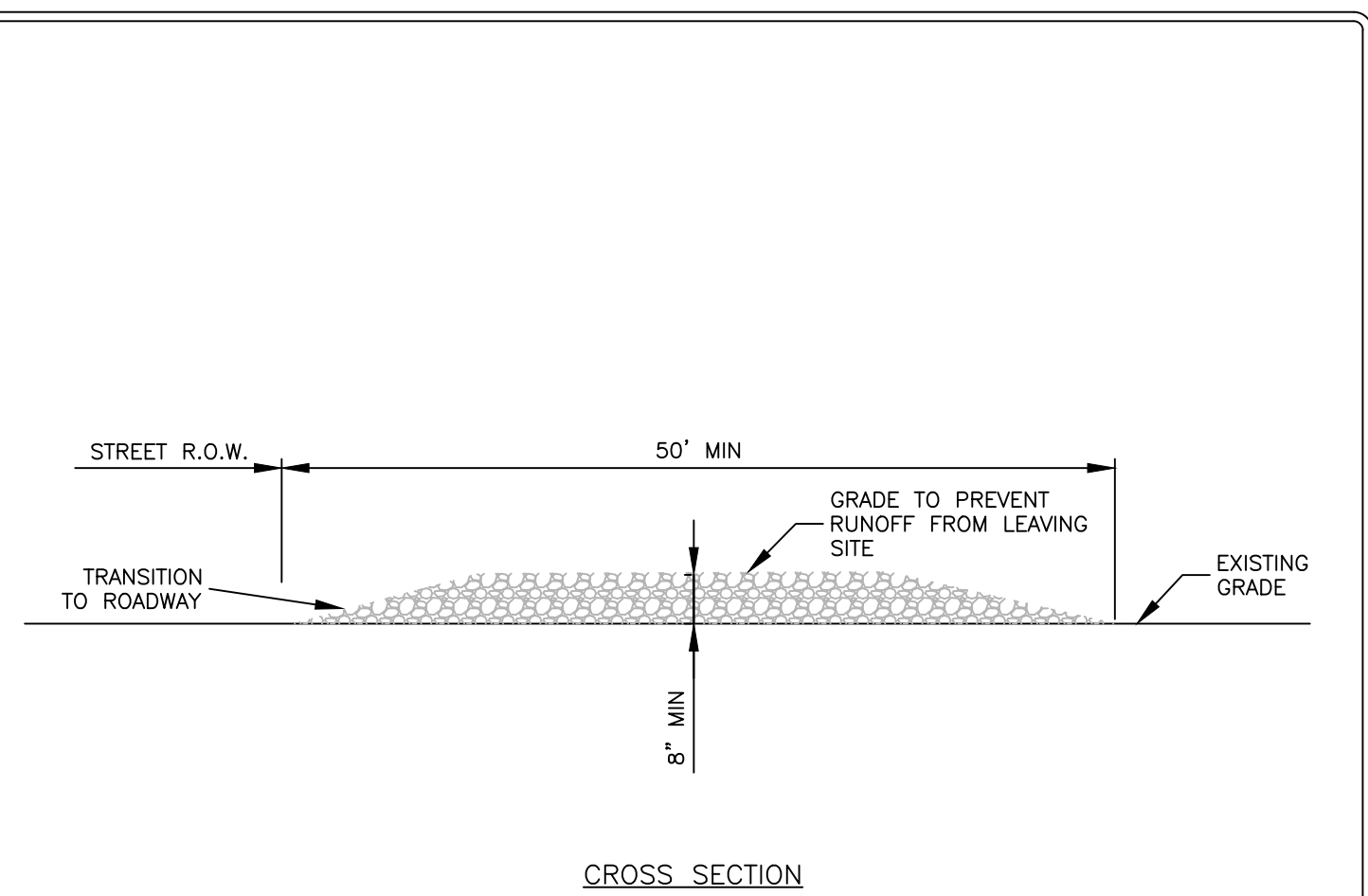

NOTES:

- STONE SIZE SHALL BE 3" - 8" OPEN GRADED ROCK.
- THICKNESS OF CRUSHED STONE PAD TO BE NOT LESS THAN 8".
- LENGTH SHALL BE A MINIMUM OF 50' FROM ACTUAL ROADWAY, AND WIDTH NOT LESS THAN FULL WIDTH OF INGRESS/EGRESS.
- ENTRANCE SHALL BE PROPERLY GRADED TO PREVENT RUNOFF FROM LEAVING THE CONSTRUCTION SITE.
- THE ENTRANCE SHALL BE MAINTAINED IN A CONDITION WHICH WILL PREVENT TRACKING OR FLOWING OF SEDIMENT ONTO PUBLIC RIGHTS OF WAY. ALL SEDIMENT SPILLED, DROPPED, WASHED OR TRACKED ONTO PUBLIC RIGHTS OF WAY MUST BE REMOVED IMMEDIATELY BY CONTRACTOR.
- AS NECESSARY, WHEELS MUST BE CLEANED TO REMOVE SEDIMENT PRIOR TO ENTRANCE ONTO PUBLIC RIGHT OF WAY. WHEN WASHING IS REQUIRED, IT SHALL BE DONE ON AN AREA STABILIZED WITH CRUSHED STONE WHICH DRAINS INTO AN APPROVED SEDIMENT TRAP OR SEDIMENT BASIN. ALL SEDIMENT SHALL BE PREVENTED FROM ENTERING ANY STORM DRAIN, DITCH OR WATERCOURSE USING APPROVED METHODS.

RECORD SIGNED COPY ON FILE AT PUBLIC WORKS APPROVED 03-25-11 DATE	CITY OF ROUND ROCK	DRAWING NO: EC-09
STABILIZED CONSTRUCTION ENTRANCE DETAIL		
		

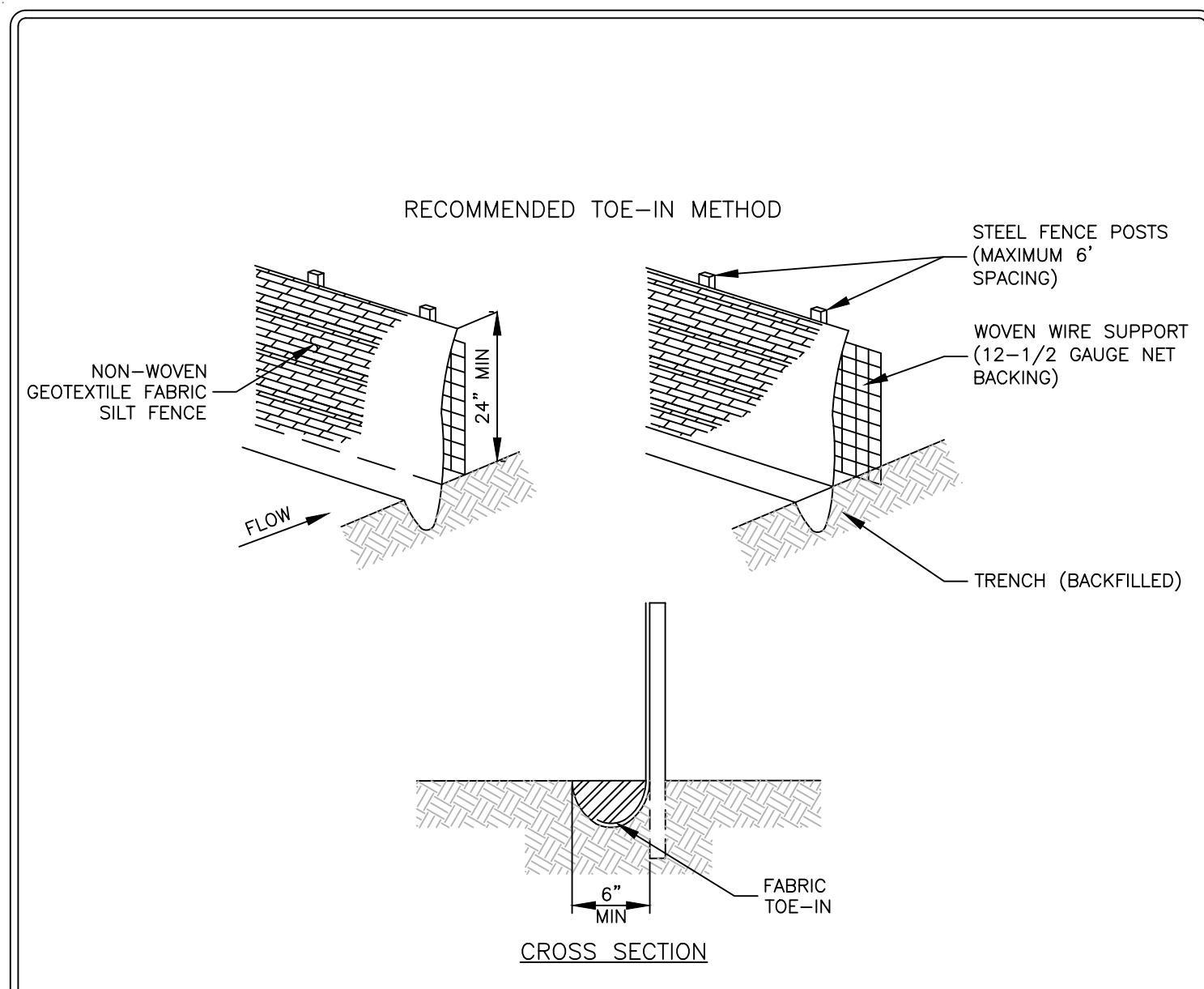

NOTES:

- STEEL POSTS WHICH SUPPORT THE SILT FENCE SHALL BE INSTALLED ON A SLIGHT ANGLE TOWARD THE ANTICIPATED RUNOFF SOURCE. POST MUST BE EMBEDDED A MIN. OF ONE (1') FOOT.
- THE TOE OF THE SILT FENCE SHALL BE TRENCHED IN WITH A SPADE OR MECHANICAL TRENCHER, SO THAT THE DOWNSLOPE FACE OF THE TRENCH IS FLAT AND PERPENDICULAR TO THE LINE OF FLOW. WHERE FENCE CANNOT BE TRENCHED IN (E.G. PAVEMENT) WEIGHT FABRIC FLAP WITH WASHED GRAVEL ON UPHILL SIDE TO PREVENT FLOW UNDER FENCE.
- THE TRENCH MUST BE A MINIMUM OF 6 INCHES DEEP AND 6 INCHES WIDE TO ALLOW FOR THE SILT FENCE FABRIC TO BE LAID IN THE GROUND AND BACKFILLED WITH COMPACTED MATERIAL.
- SILT FENCE SHALL BE SECURELY FASTENED TO EACH STEEL SUPPORT POST OR TO WOVEN WIRE, WHICH IN TURN IS SECURELY FASTENED TO THE SILT FENCE POSTS.
- INSPECTION SHALL BE MADE WEEKLY OR AFTER EACH RAINFALL EVENT AND REPAIR OR REPLACEMENT SHALL BE MADE PROMPTLY AS NEEDED.
- SILT FENCE SHALL BE REMOVED WHEN THE SITE IS COMPLETELY STABILIZED SO AS NOT TO BLOCK OR IMPEDE STORM FLOW OR DRAINAGE.
- ACCUMULATED SILT SHALL BE REMOVED WHEN IT REACHES A DEPTH OF 6 INCHES. THE SILT SHALL BE DISPOSED OF IN AN APPROVED SITE AND IN SUCH A MANNER AS TO NOT CONTRIBUTE TO ADDITIONAL SILTATION.
- SILT FENCE SHALL BE REMOVED AS SOON AS THE SOURCE OF SEDIMENT IS STABILIZED.

RECORD SIGNED COPY ON FILE AT PUBLIC WORKS APPROVED 03-25-11 DATE	CITY OF ROUND ROCK	DRAWING NO: EC-10
SILT FENCE DETAIL		
		

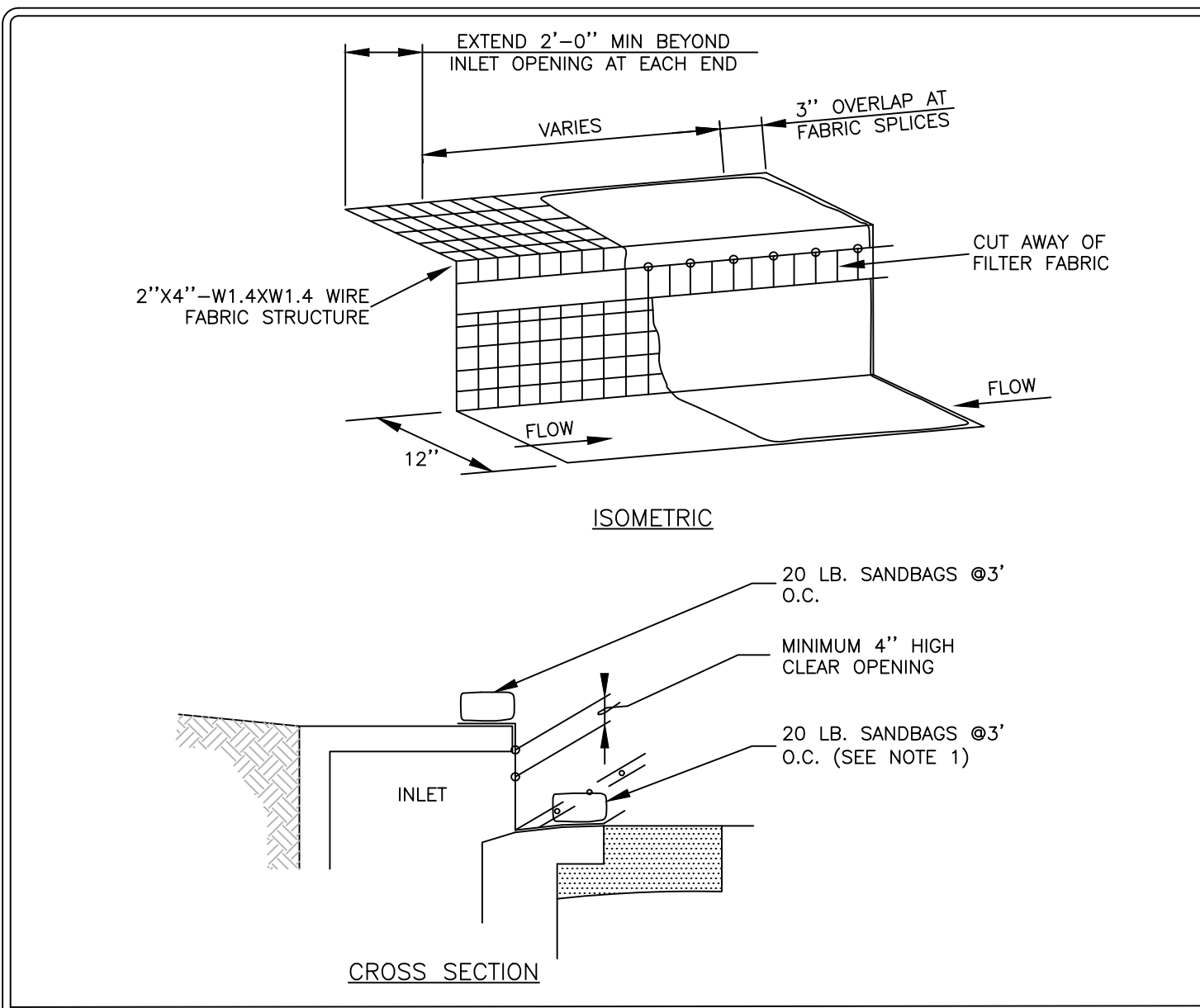

NOTES:

- WHERE MINIMUM CLEARANCES CAUSE TRAFFIC TO DRIVE IN THE GUTTER, THE CONTRACTOR MAY SUBSTITUTE A 1" X 4" BOARD SECURED WITH CONCRETE NAILS 3' O.C. NAILED INTO THE GUTTER IN LIEU OF SANDBAGS TO HOLD THE FILTER DIKE IN PLACE. UPON REMOVAL, CLEAN ANY DIRT/DEBRIS FROM NAILING LOCATIONS, APPLY CHEMICAL SANDING AGENT AND APPLY NON-SHRINK GROUT FLUSH WITH SURFACE OF GUTTER.
- A SECTION OF FILTER FABRIC SHALL BE REMOVED AS SHOWN ON THIS DETAIL OR AS DIRECTED BY THE ENGINEER OR DESIGNATED REPRESENTATIVE. FABRIC MUST BE SECURED TO WIRE BACKING WITH CLIPS OR HOG RINGS AT THIS LOCATION.
- DAILY INSPECTION SHALL BE MADE BY THE CONTRACTOR AND SILT ACCUMULATION MUST BE REMOVED WHEN DEPTH REACHES 2".
- CONTRACTOR SHALL MONITOR THE PERFORMANCE OF INLET PROTECTION DURING EACH RAINFALL EVENT AND IMMEDIATELY REMOVE THE INLET PROTECTIONS IF THE STORM-WATER BEGINS TO OVERTOP THE CURB.
- INLET PROTECTIONS SHALL BE REMOVED AS SOON AS THE SOURCE OF SEDIMENT IS STABILIZED.

RECORD SIGNED COPY ON FILE AT PUBLIC WORKS APPROVED 03-25-11 DATE	CITY OF ROUND ROCK	DRAWING NO: EC-14
CURB INLET PROTECTION DETAIL		
		

LANGAN
Langan Engineering and Environmental Services, Inc.
9606 N. Mopac Expressway, Suite 110
Austin, TX 78759
T: 737.289.7800 F: 737.289.7801 www.langan.com
TBPE FIRM REG. #F-13709

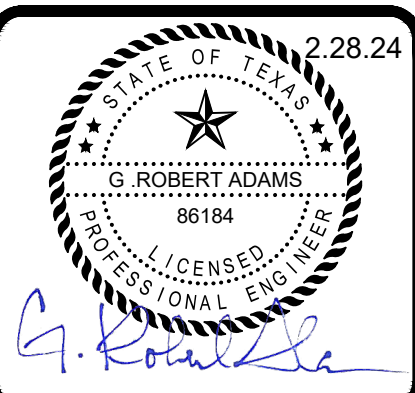

REVISIONS

NO.	DATE	DESCRIPTION

JADE AT CHISHOLM TRAIL
 392 APARTMENT UNITS IN ROUND ROCK, TEXAS
 GLENRIDGE DEVELOPMENT

PERMIT SET
 ISSUED 02-28-2024

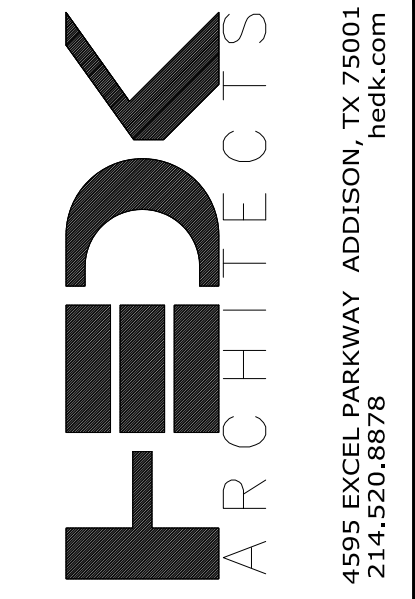

DATE
02-28-2024

PROJECT
22137

SHEET NUMBER
C8.00

EROSION CONTROL DETAILS (1 OF 2)

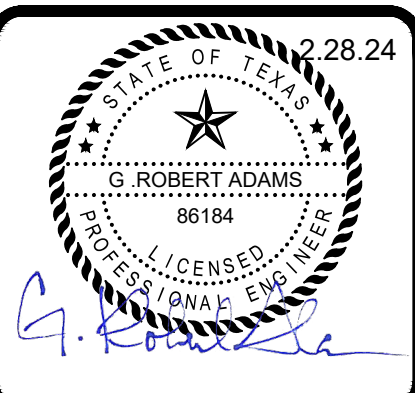

REVISIONS

JADE AT CHISHOLM TRAIL
 392 APARTMENT UNITS IN ROUND ROCK, TEXAS
 GLENRIDGE DEVELOPMENT

PERMIT SET
 ISSUED 02-28-2024

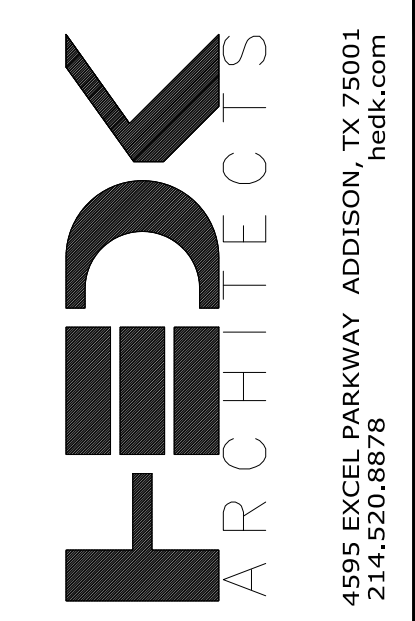

DATE
02-28-2024

PROJECT
22137

SHEET NUMBER
C8.04

SANITARY DETAILS
(1 OF 2)

COPYRIGHT © HEDK Architects ALL RIGHTS RESERVED

LANGAN
 Langan Engineering and Environmental Services, Inc.
 9606 N. Mopac Expressway, Suite 110
 Austin, TX 78759
 T: 737.289.7800 F: 737.289.7801 www.langan.com
 TBPE FIRM REG. #F-13709

CoRR Tracking Number : SDP23-00054

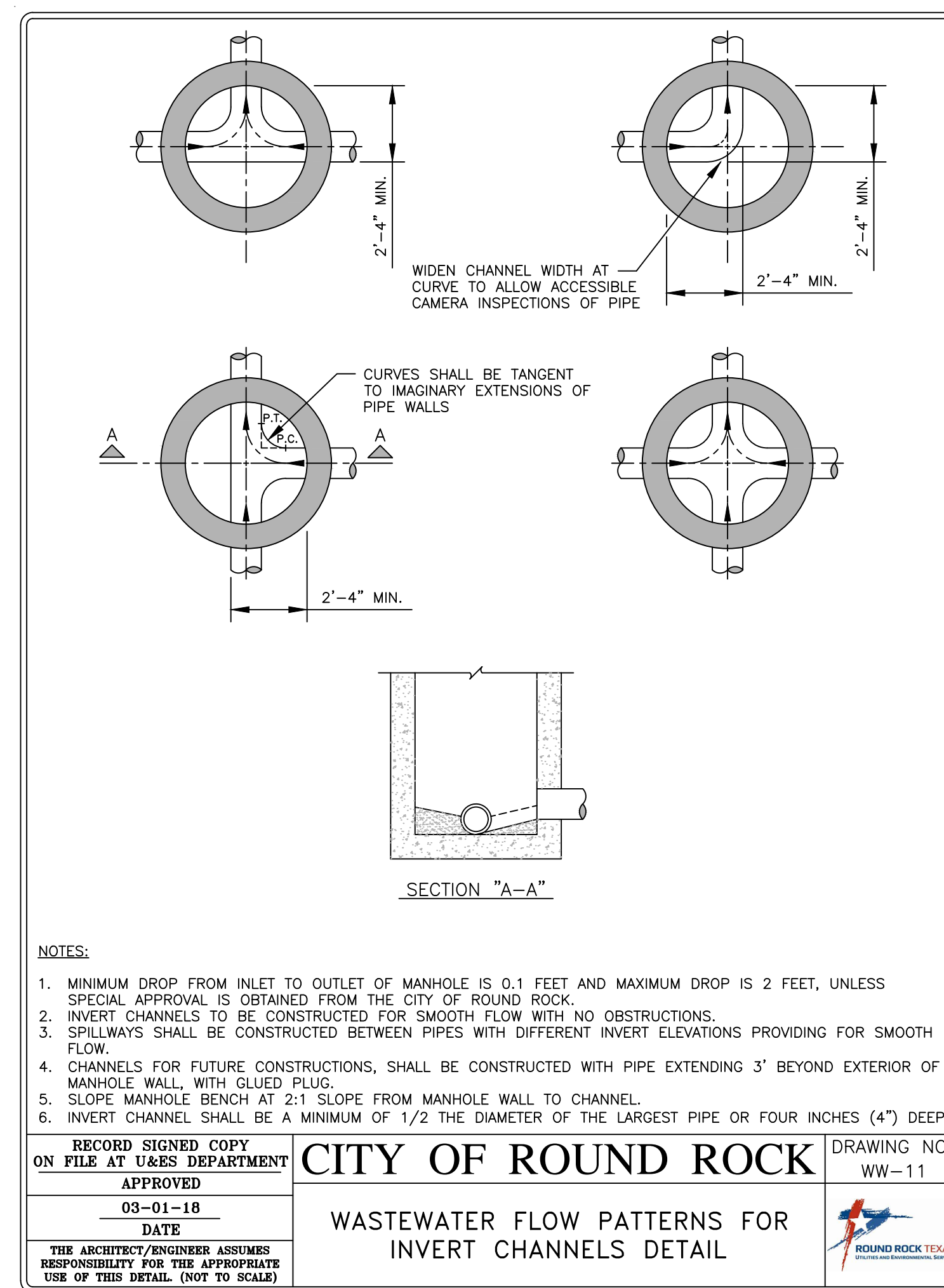
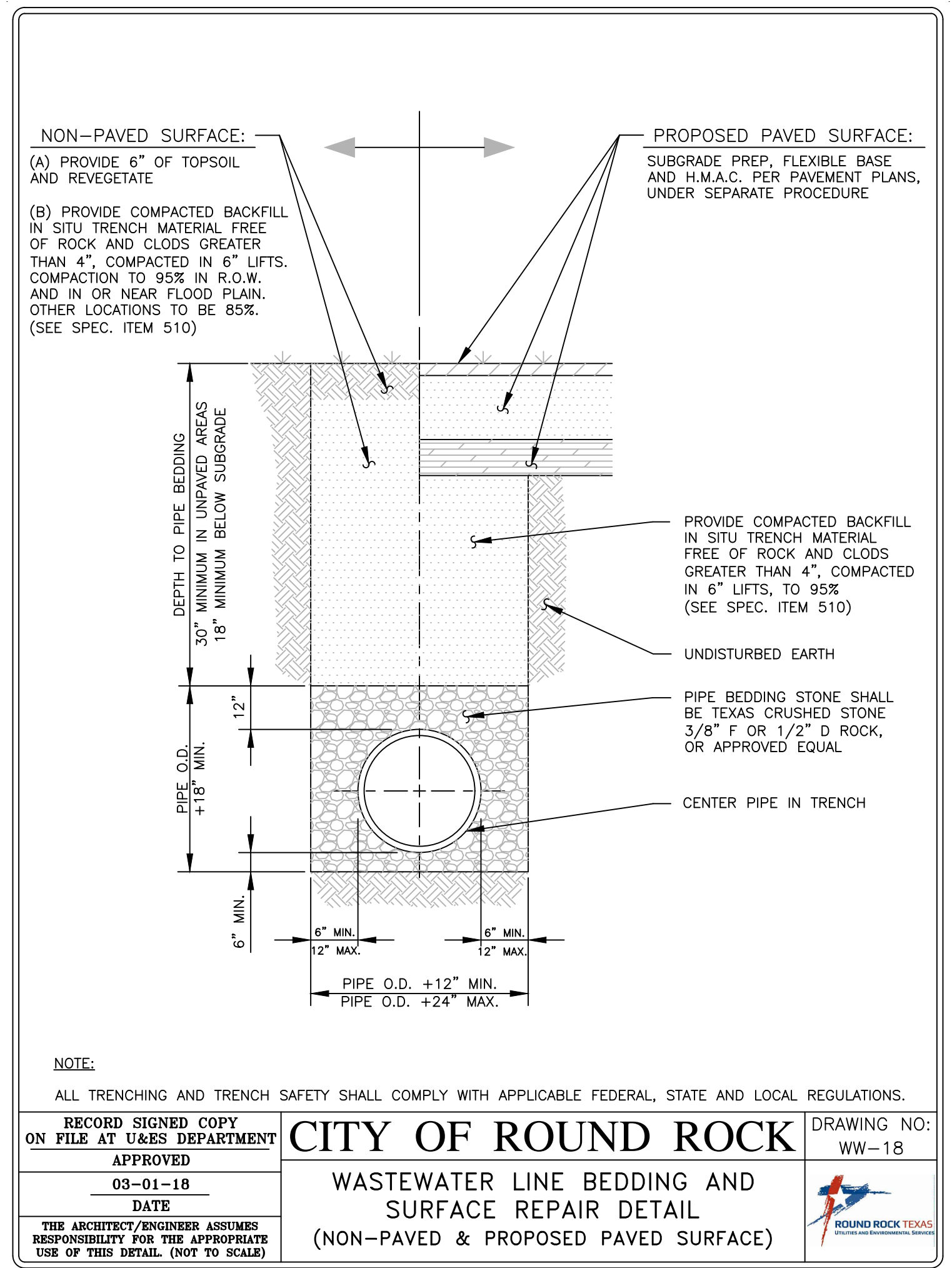
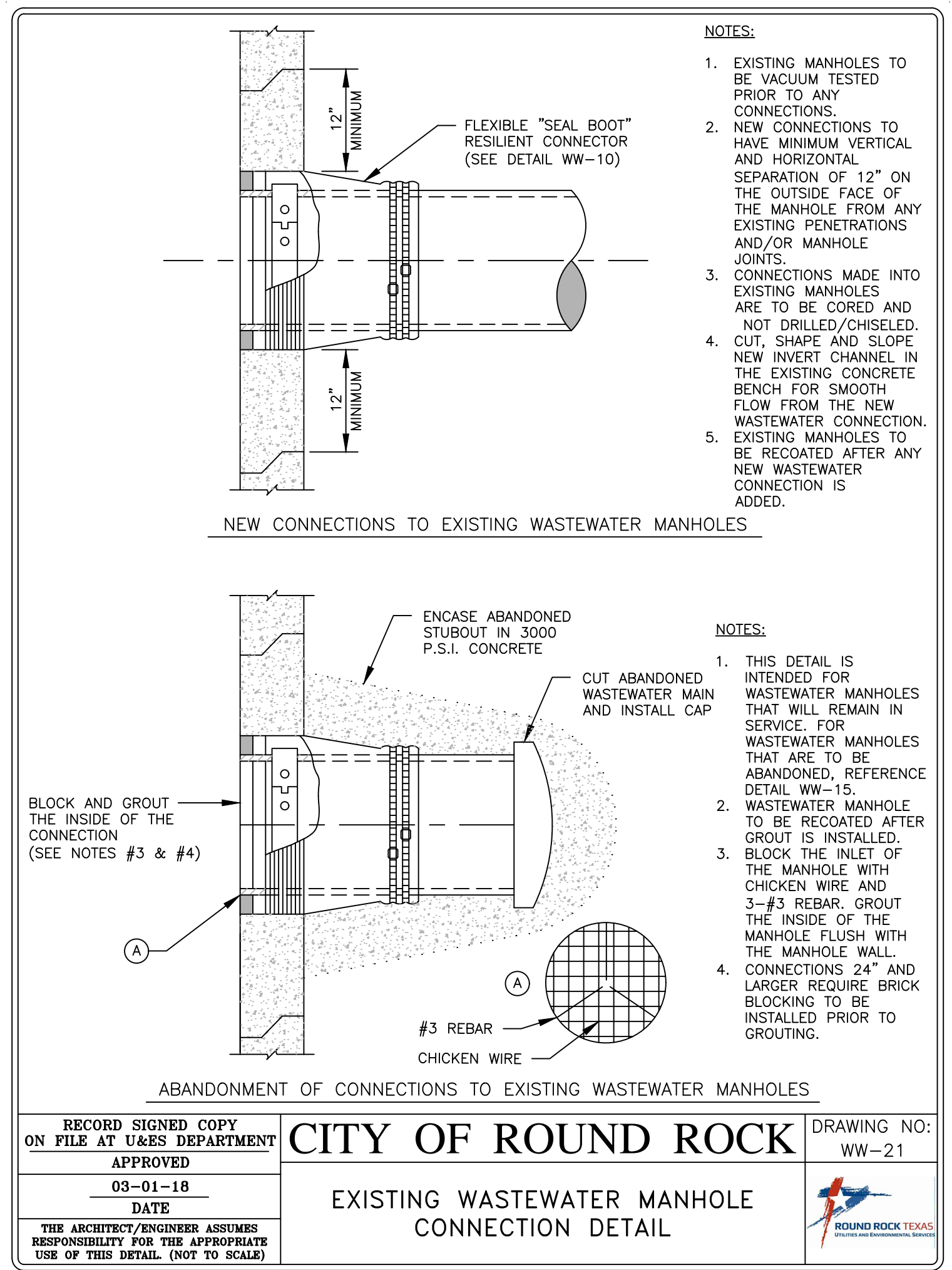
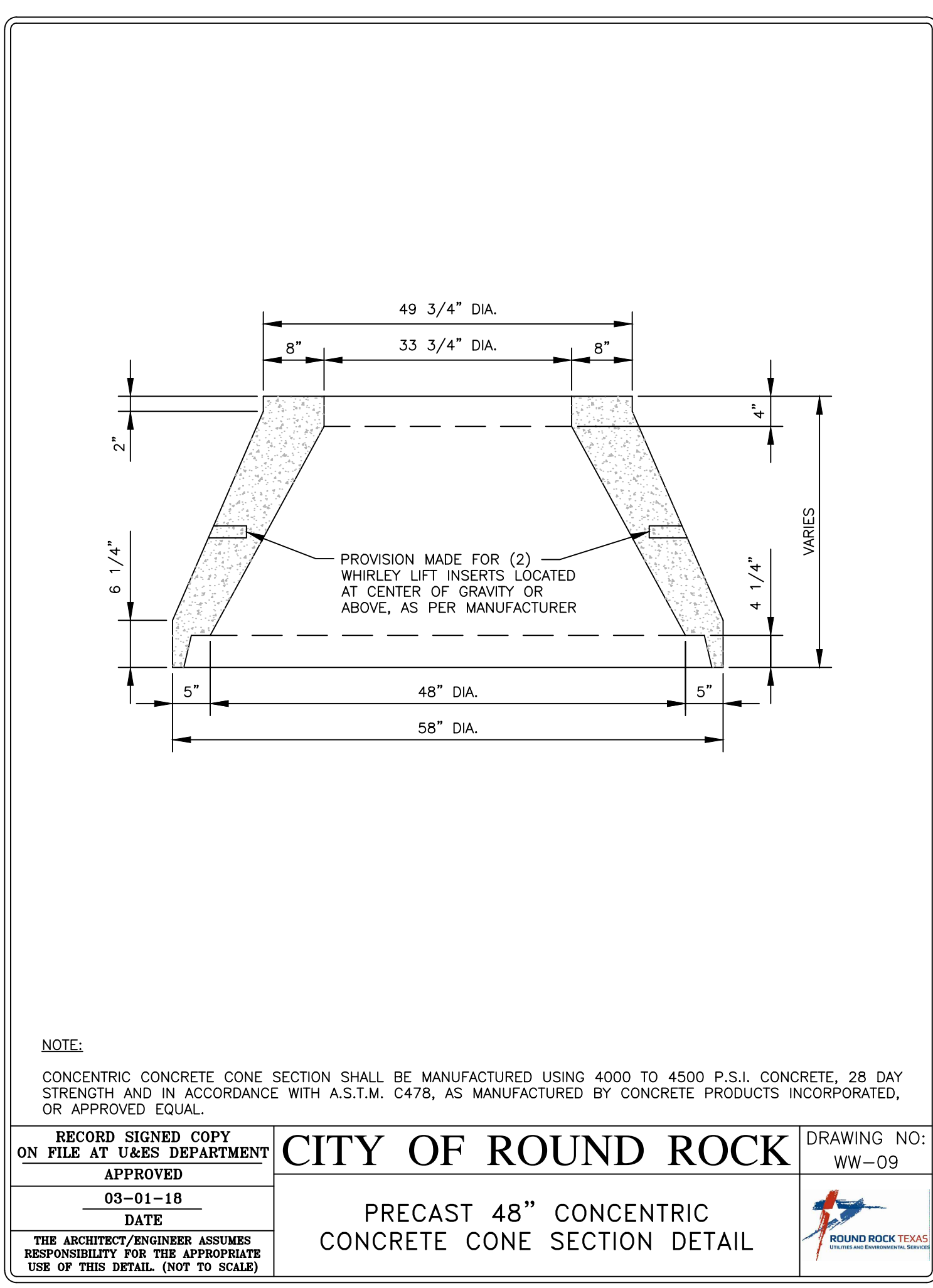
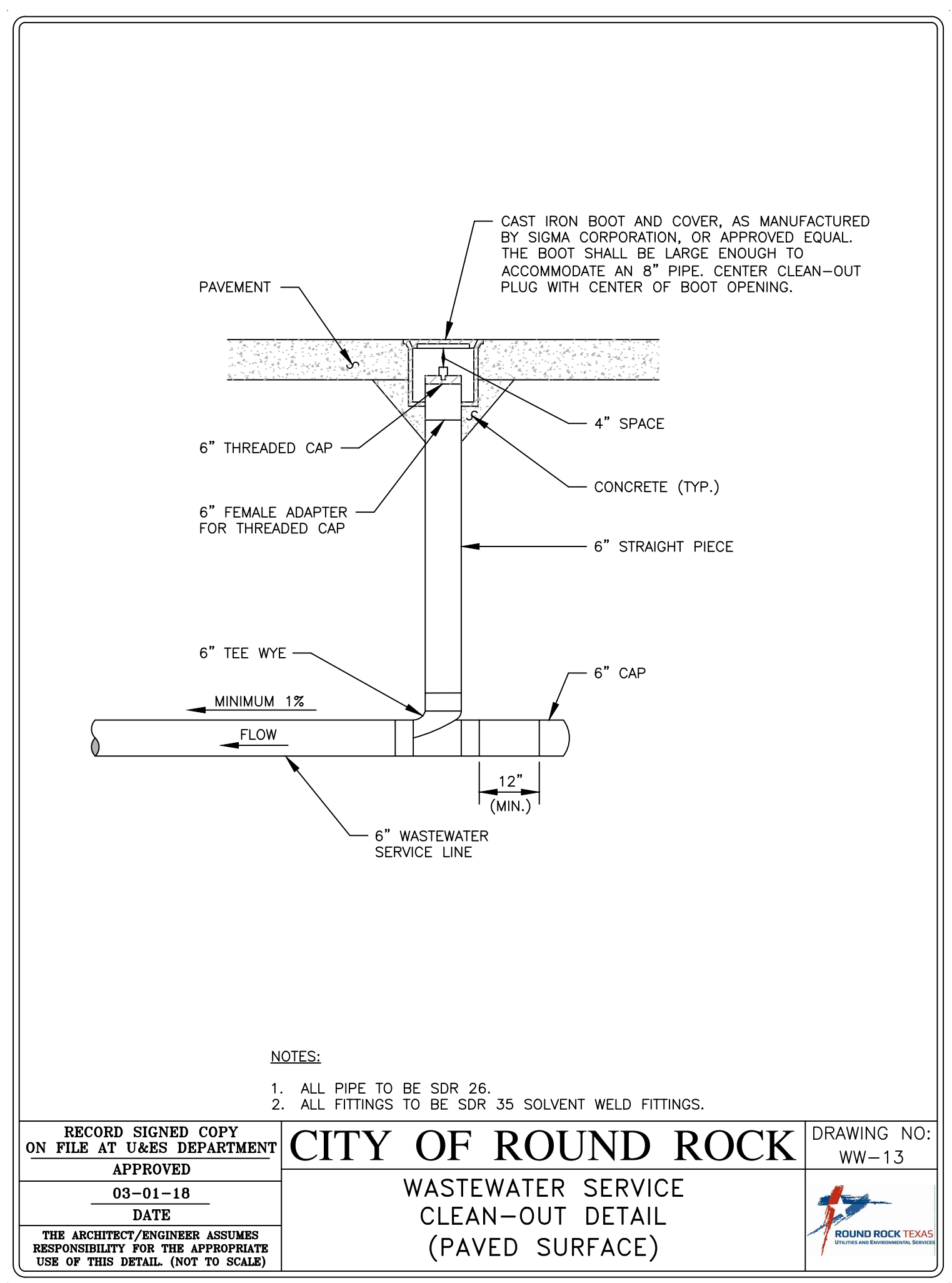
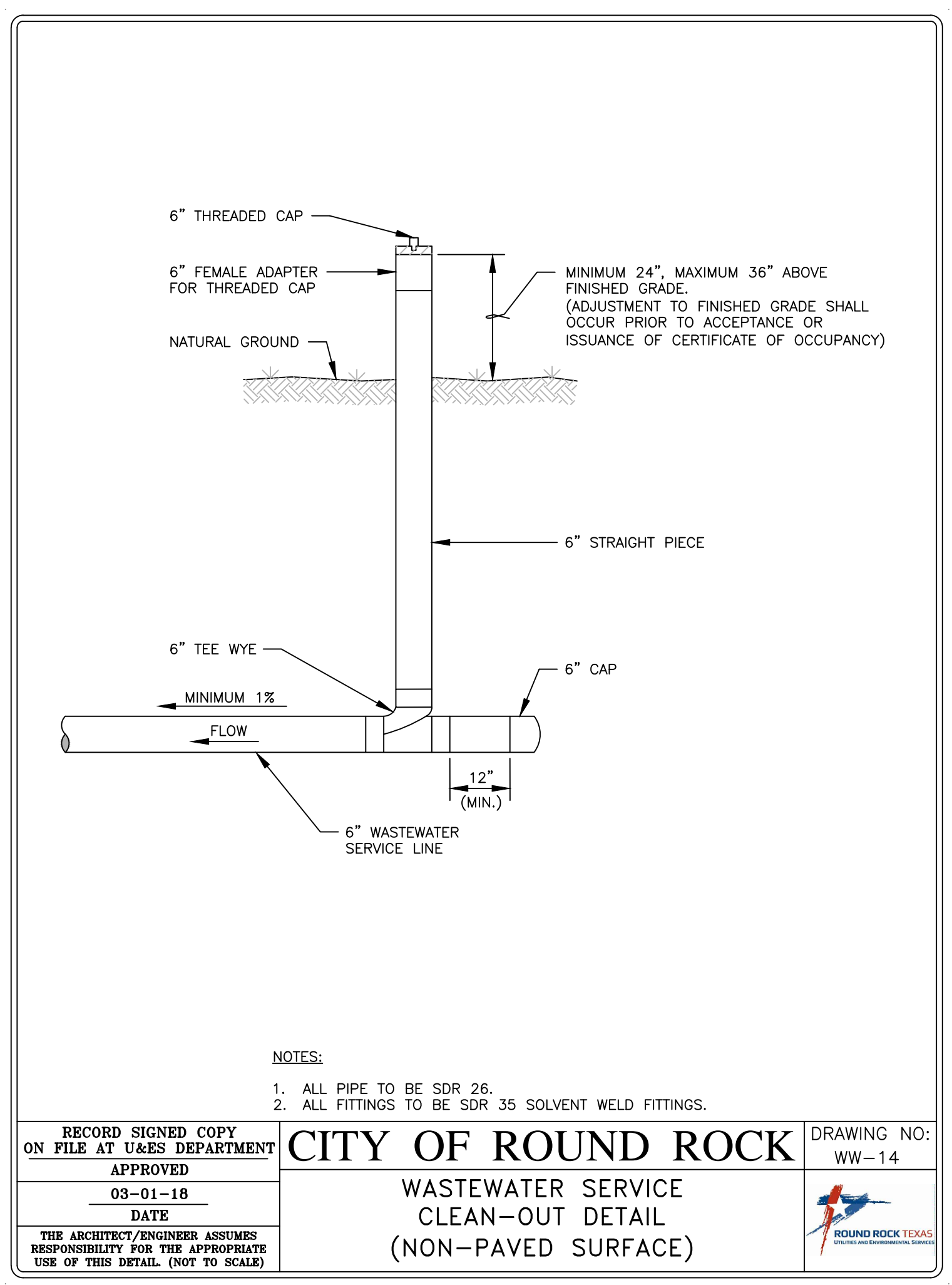

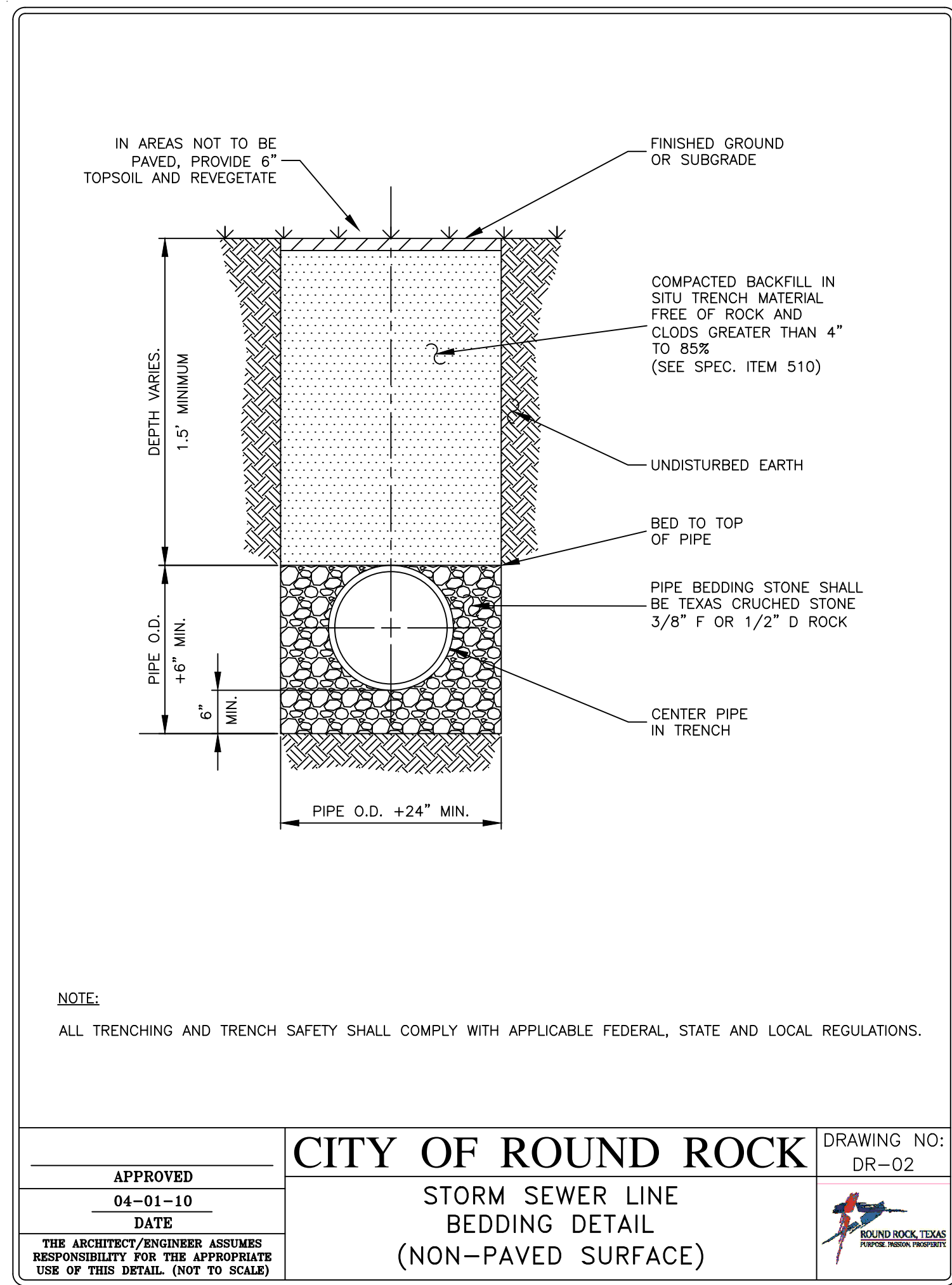

CITY OF ROUND ROCK
STORM SEWER LINE BEDDING DETAIL (NON-PAVED SURFACE)
 DRAWING NO: DR-02

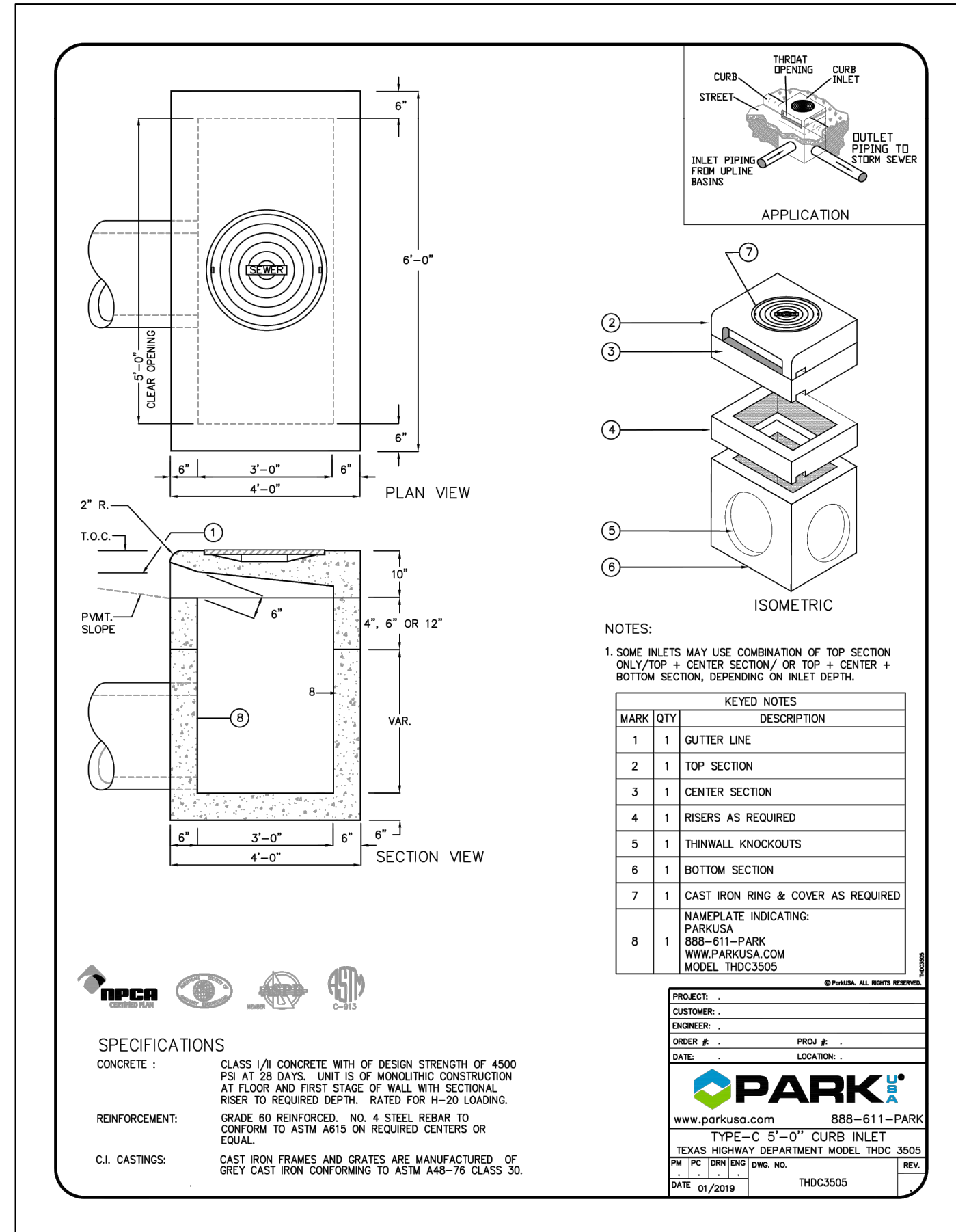

CITY OF ROUND ROCK
BOLTED STORMSEWER MANHOLE COVER AND FRAME DETAIL
 DRAWING NO: DR-05

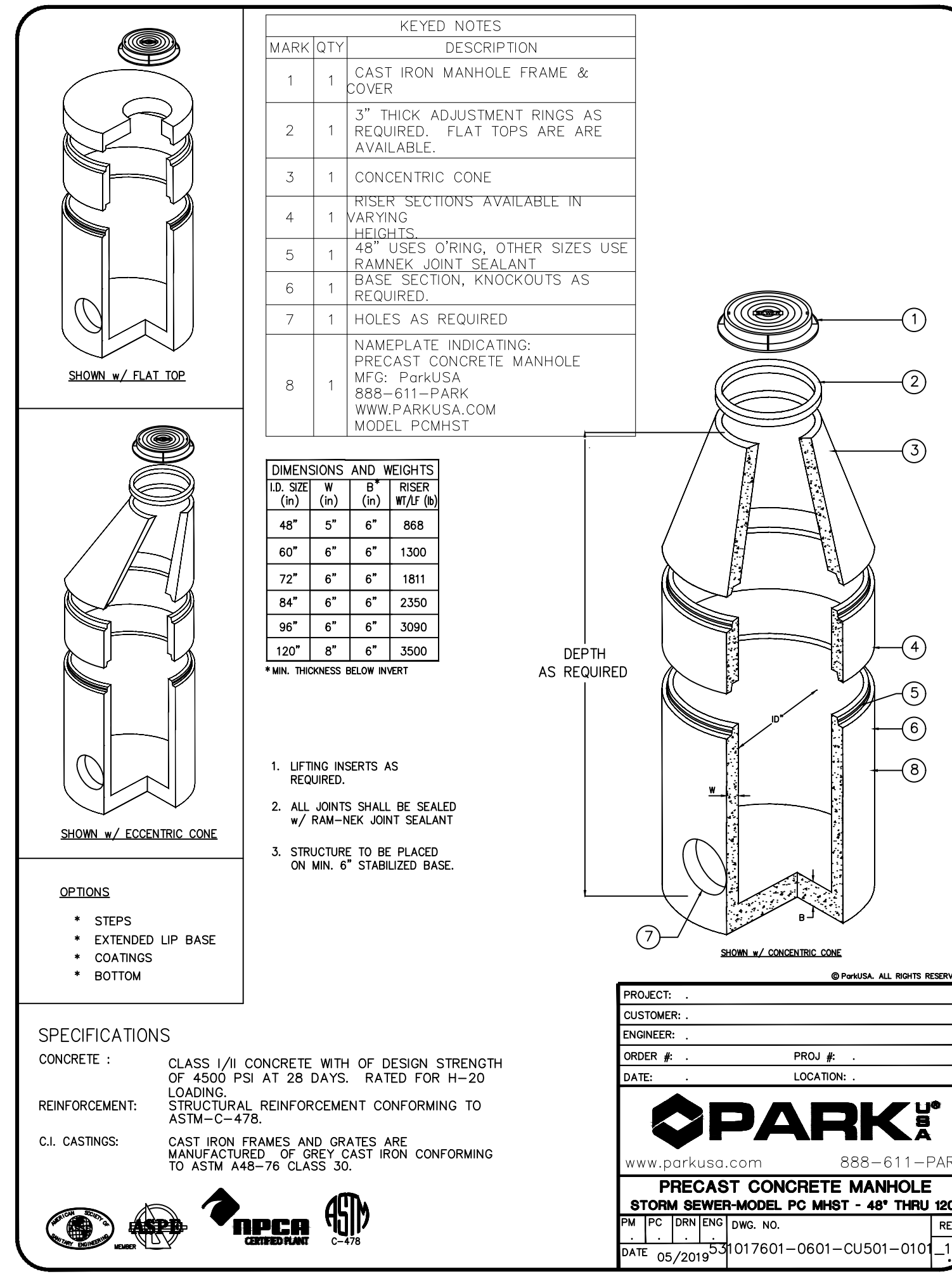

CITY OF ROUND ROCK
STORM SEWER INLET COVER AND FRAME DETAIL
 DRAWING NO: DR-07

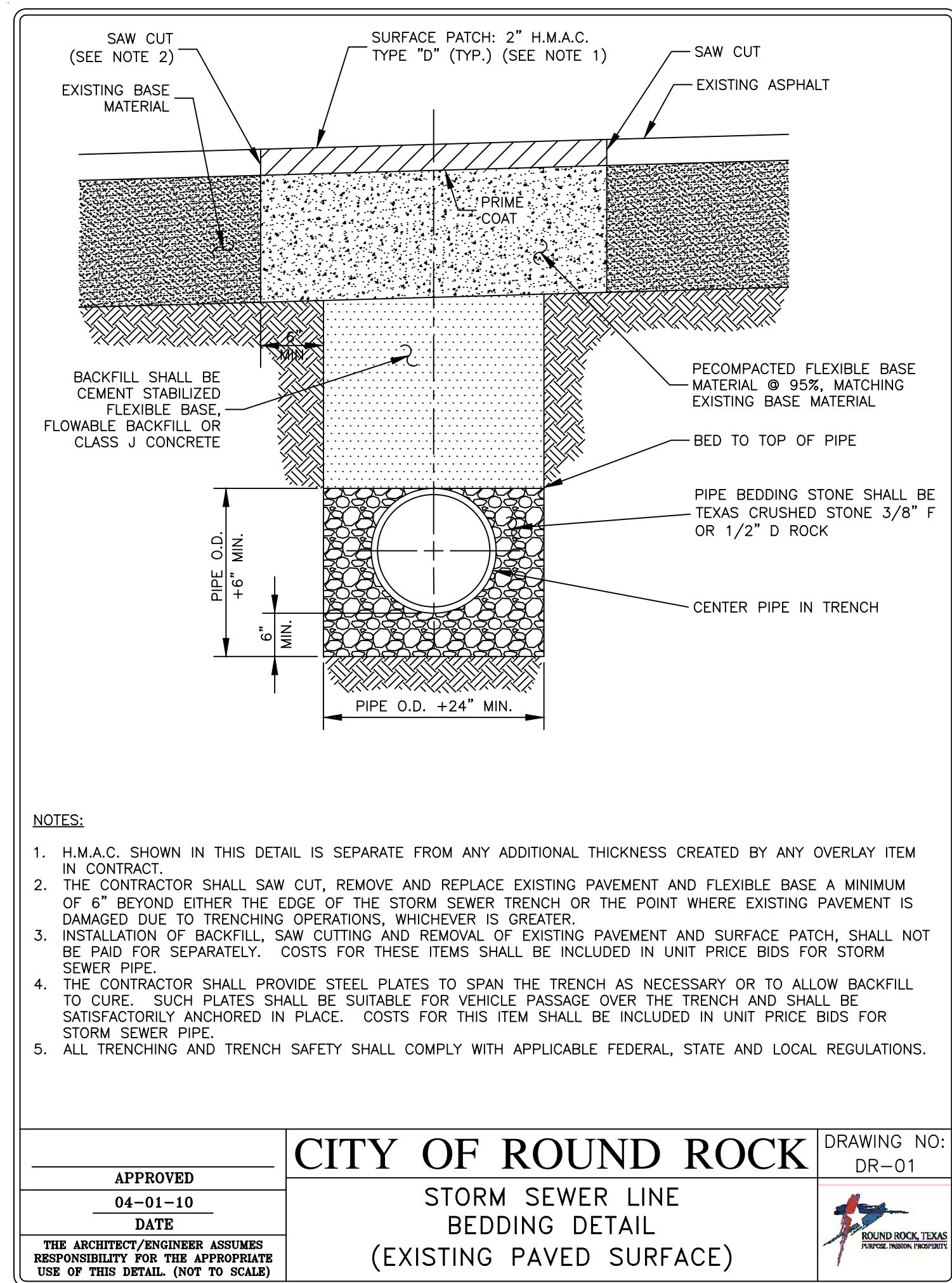

CITY OF ROUND ROCK
STORM SEWER LINE BEDDING DETAIL (EXISTING PAVED SURFACE)
 DRAWING NO: DR-01

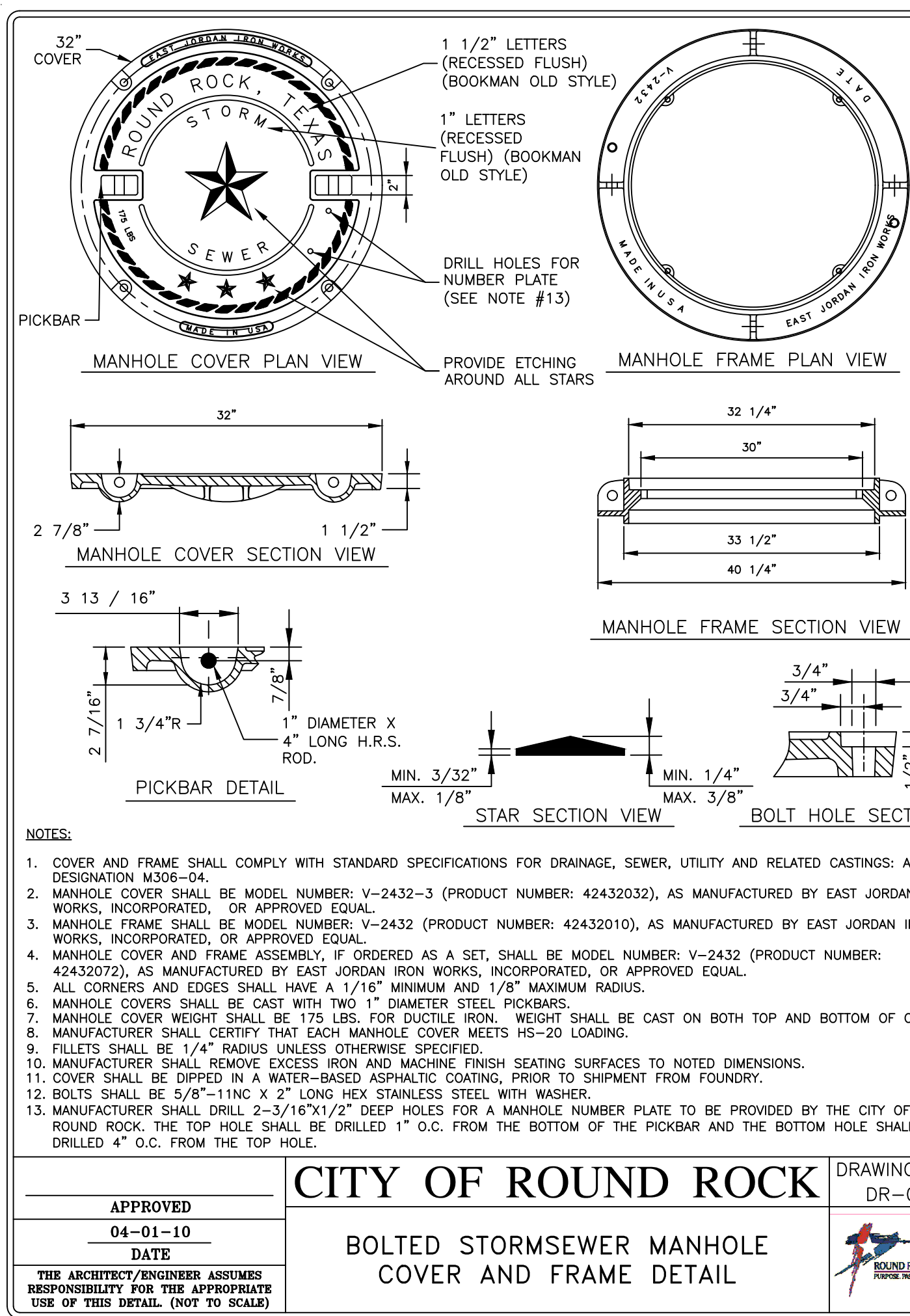

CITY OF ROUND ROCK
BOLTED STORMSEWER MANHOLE COVER AND FRAME DETAIL
 DRAWING NO: DR-05

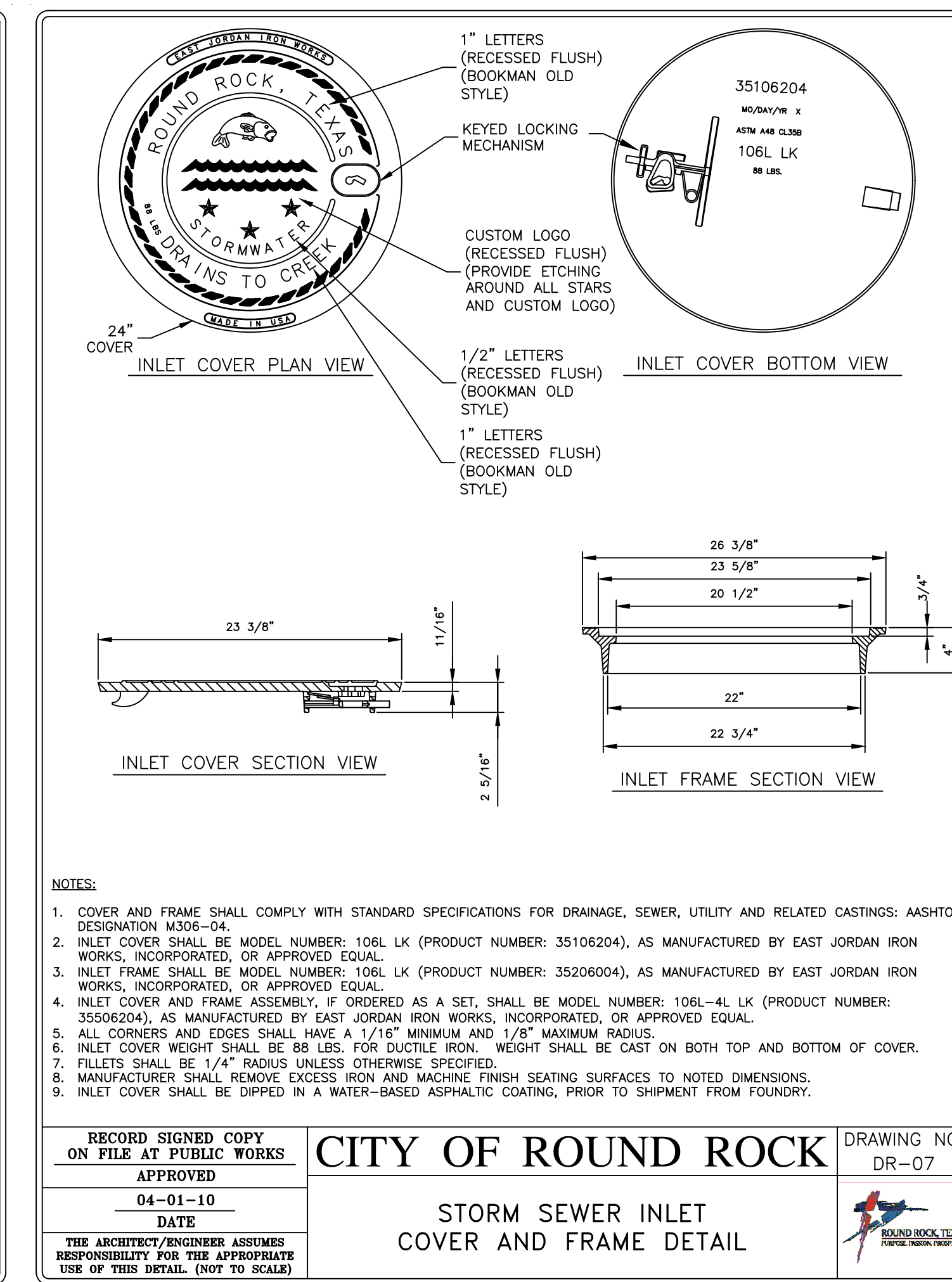

CITY OF ROUND ROCK
STORM SEWER INLET COVER AND FRAME DETAIL
 DRAWING NO: DR-07

LANGAN
 Langan Engineering and Environmental Services, Inc.
 9606 N. Mopac Expressway, Suite 110
 Austin, TX 78759
 T: 737.289.7800 F: 737.289.7801 www.langan.com
 TBPE FIRM REG. #F-13709

STATE OF TEXAS
 G. ROBERT ADAMS
 88184
 LICENSED PROFESSIONAL ENGINEER

REVISIONS

JADE AT CHISHOLM TRAIL
 392 APARTMENT UNITS IN ROUND ROCK, TEXAS
 GLENRIDGE DEVELOPMENT

PERMIT SET
 ISSUED 02-28-2024

HEDK
 ARCHITECTS
 4595 EXCEL PARKWAY ADDISON, TX 75001
 214.520.8878

DATE: 02-28-2024
 PROJECT: 22137
 SHEET NUMBER: C8.06
 DRAINAGE DETAILS (1 OF 3)

COPYRIGHT © HEDK Architects ALL RIGHTS RESERVED

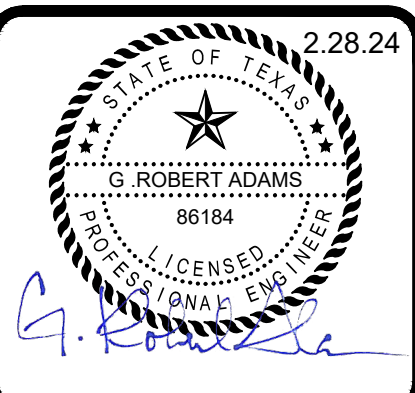

REVISIONS

NO.	DATE	DESCRIPTION

JADE AT CHISHOLM TRAIL
 392 APARTMENT UNITS IN ROUND ROCK, TEXAS
 GLENRIDGE DEVELOPMENT

PERMIT SET
 ISSUED 02-28-2024

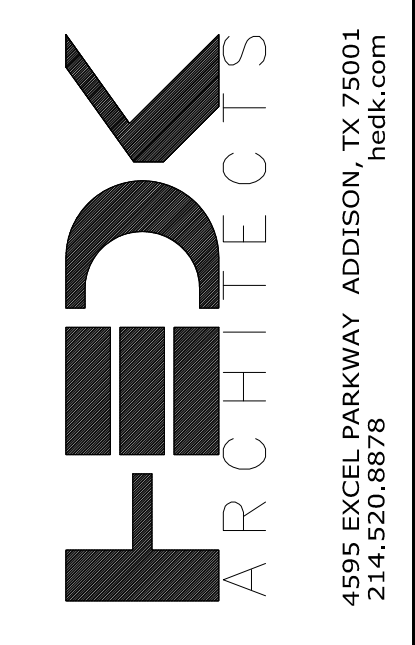

DATE
02-28-2024

PROJECT
22137

SHEET NUMBER
C8.08

DRAINAGE DETAILS
(3 OF 3)

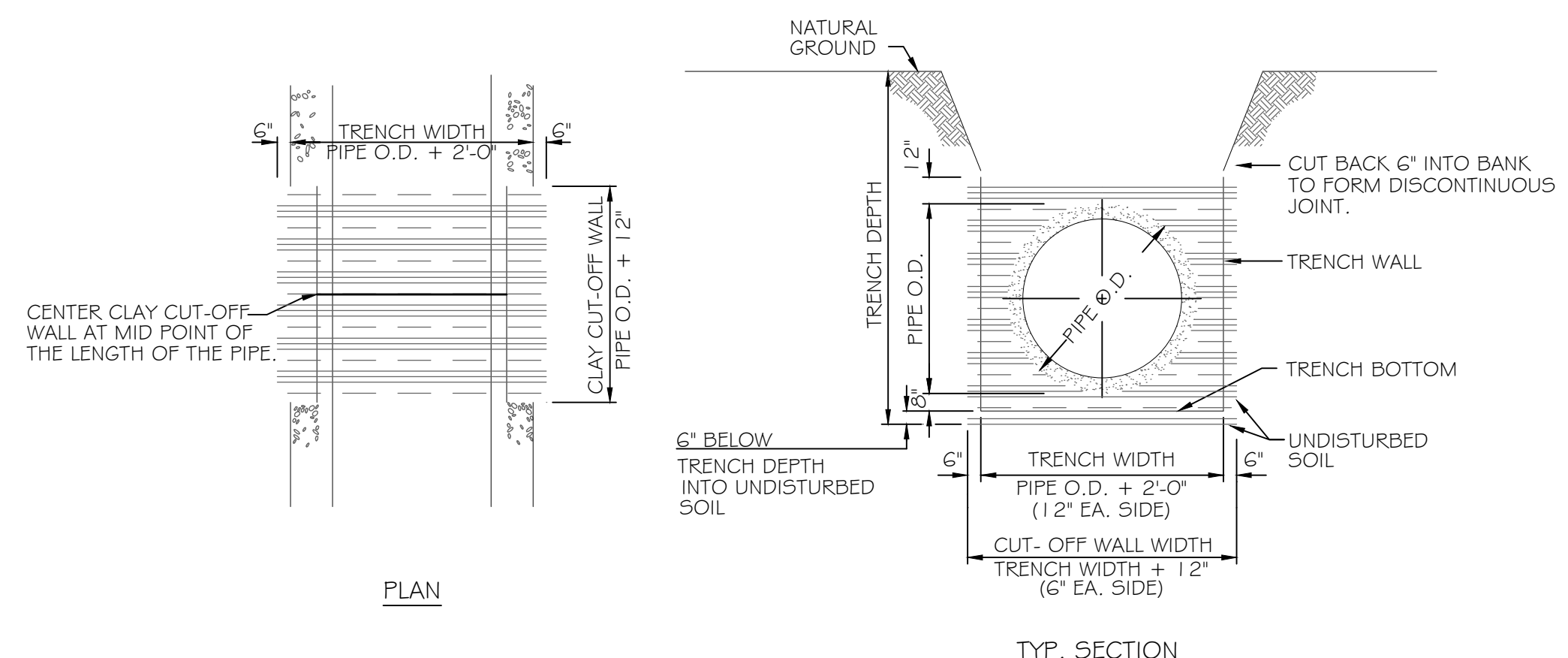

- CLAY CUT-OFF WALL NOTES:**
1. CLAY CUT-OFF WALLS SHALL BE CONSTRUCTED AT APPROXIMATELY 250 FOOT INTERVALS ALONG ALL STORM DRAIN CONDUITS HAVING CRUSHED STONE EMBEDMENT.
 2. THE CLAY CUT-OFF WALL SHALL BE PLACED AT THE MID POINT OF THE LENGTH OF THE PIPE BEING PLACED, BUT NOT AT A LOCATION WHERE A LATERAL CONNECTS TO THE MAIN. THE MINIMUM CLEARANCE IS 10 FEET.
 3. MATERIAL FOR CLAY CUT-OFF WALL TO BE CLEAN MATERIAL WITH NO LUMPS LARGER THAN 3". CLAY TO HAVE P.I. OF 30 TO 40. MATERIAL TO BE PLACED IN 6" LIFTS, MOISTENED TO OPTIMUM MOISTURE CONTENT AND COMPACTED WITH HAND HELD MECHANICAL TAMPERS, WITHOUT DAMAGING THE PIPE.

STORM DRAIN CLAY CUT-OFF WALL
N.T.S.

TYPE OF STRUCTURE

JB - Junction Box
MH - Manhole

Base Section Size

4 - 4'
5 - 5'
6 - 6'
7 - 7'
8 - 8'

RISER SECTION SIZE

1 - 1'
2 - 2'
3 - 3'
4 - 4'

PARK MODEL NO. TXX-XX-X-XXXX-XX

SIZE OF R/C OR R/G (DIA.)

01 - 24" 05 - 42"
02 - 32" 06 - 48"
03 - 30" 07 - Other
04 - 36"

CASTING TYPE

DI - Ductile Iron
CI - Cast Iron

CASTING STYLE

RC - Ring & Cover
RG - Ring & Grate
DG - Dome Grate

DIMENSIONS						
ID. Size	O.D. Dim "A"	"B"	Top/Bottom Thickness (n)	Largest RCP Allowed (No Angle, Straight In)	Largest Box Culvert Allowed (No Angle, Straight In)	
4' x 4'	5' x 5'	6"	6"	36"	3' x 3'	
5' x 5'	6' x 6'	6"	6"	48"	4' x 4'	
6' x 6'	7'-4" x 7'-4"	8"	8"	54"	4' x 4'	
7' x 7'	8'-4" x 8'-4"	8"	8"	66"	5' x 5'	
8' x 8'	9'-4" x 9'-4"	8"	8"	78"	6' x 6'	
9' x 9'	10'-4" x 10'-4"	8"	8"	84"	7' x 7'	

KEYED NOTES

MARK	QTY	DESCRIPTION
1	1	CASTING TO BE 24" OR 32" RING AND COVER (AS REQ'D)
2	1	GRADE RINGS (AS REQ'D)
3	1	RAMNEK JOINT
4	1	BLOCKOUT TYPE, SIZE, AND LOCATION WILL VARY PER CUSTOMER AND/OR PLAN SPECIFICATIONS.
5	1	RCP (BY OTHERS)
6	1	TRANSITIONAL MANHOLE PARK ENVIRONMENTAL WWW.PARKUSA.COM MODEL- TMH

SPECIFICATIONS

CONCRETE: CLASS I/II CONCRETE WITH DESIGN STRENGTH OF 4500 PSI AT 28 DAYS. UNIT IS OF MONOLITHIC CONSTRUCTION AT FLOOR AND FIRST STAGE OF WALL WITH SECTIONAL RISER TO REQUIRED DEPTH. RATED GRADE 60 REINFORCED. NO. 4 STEEL REBAR TO CONFORM TO ASTM A631 ON REQUIRED CENTERS OR BRANIFFON FRAMES AND GRATES ARE MANUFACTURED OF GREY CAST IRON CONFORMING TO ASTM A48-76 CLASS 30.

REINFORCEMENT: GRADE 60 REINFORCED WITH STEEL REBAR TO CONFORM TO ASTM A631 ON REQUIRED CENTERS OR EQUAL.

CL. CASTINGS: CAST IRON FRAMES AND GRATES ARE MANUFACTURED OF GREY CAST IRON CONFORMING TO ASTM A48-76 CLASS 30.

PROJECT: _____
CUSTOMER: _____
ENGINEER: _____
ORDER #: _____ **PROJ #:** _____
DATE: _____ **LOCATION:** _____

PARK USA
www.parkusa.com 888-611-PARK
TRANSITIONAL MANHOLE/JUNCTION BOX

PM PC DRN ENG DWG. NO. REV.
DATE 01/2019 017601-0601-CU501-010 1

ISOMETRIC VIEW

GRATE SCHEDULE			
GRATE = 200 RA	MODEL NO. V4880-1	OPEN AREA = 489 sf	
GRATE = 240 RA	MODEL NO. V4880-3	OPEN AREA = 434 sf	
GRATE = 270 RA	MODEL NO. V4880-4	OPEN AREA = 387 sf	

KEYED NOTES

MARK	QTY	DESCRIPTION
1	1	CAST IRON FRAME & GRATE
2	1	TOP SECTION
3	1	PRECAST CONCRETE BASIN SECTION
4	1	THIN WALL KNOCKOUT ON ALL 4 SIDES. SEE KO DIMENSION FOR MAXIMUM PIPE O.D.
5	1	PRECAST CATCH BASIN MFG: PARKUSA 888-611-PARK WWW.PARKUSA.COM MODEL: CB5600-1

NOTE: RISER SECTION AVAILABLE IN 6" TO 12" DEPTHS.

MODEL	W1	W2	H1	H2	T1	T2	KO	GRATE SIZE	OPEN AREA	WEIGHT LBS
CB-12	10"	10"	18"	3"	2"	10"	12"x12"x1"	90	180	
CB-14	20"	12"	28"	24"	4"	12"	14"x14"x1"	120	600	
CB-18	24"	18"	34"	30"	4"	15"	18"x18"x1"	188	1,000	
CB-20	28"	18"	34"	30"	4"	17"	20"x20"x1"	170	1,330	
CB-24	32"	22"	41"	36"	5"	22"	24"x24"x2"	268	2,245	
CB-27	37"	25"	44"	36"	6"	24"	27"x27"x2"	350	2,875	

SPECIFICATIONS

CONCRETE: CLASS I/II CONCRETE WITH DESIGN STRENGTH OF 4500 PSI AT 28 DAYS. UNIT IS OF MONOLITHIC CONSTRUCTION AT FLOOR AND FIRST STAGE OF WALL WITH SECTIONAL RISER TO REQUIRED DEPTH. RATED FOR H-20 LOADING.

REINFORCEMENT: GRADE 60 REINFORCED WITH STEEL REBAR TO CONFORM TO ASTM A631 ON REQUIRED CENTERS OR EQUAL.

CL. CASTINGS: CAST IRON FRAMES AND GRATES ARE MANUFACTURED OF GREY CAST IRON CONFORMING TO ASTM A48-76 CLASS 30.

PROJECT: _____
CUSTOMER: _____
ENGINEER: _____
ORDER #: _____ **PROJ #:** _____
DATE: _____ **LOCATION:** _____

PARK USA
www.parkusa.com 888-611-PARK
TYPE-A GRATE INLET MODEL: CB5600 12" THRU 27"

PM PC DRN ENG DWG. NO. REV.
DATE 01/2019 CB5600-1

ISOMETRIC VIEW

GRATE SCHEDULE			
GRATE = 200 RA	MODEL NO. V4880-1	OPEN AREA = 489 sf	
GRATE = 240 RA	MODEL NO. V4880-3	OPEN AREA = 434 sf	
GRATE = 270 RA	MODEL NO. V4880-4	OPEN AREA = 387 sf	

KEYED NOTES

MARK	QTY	DESCRIPTION
1	1	CAST IRON FRAME & GRATE
2	1	TOP SECTION
3	1	PRECAST CONCRETE BASIN SECTION
4	4	THIN WALL KNOCKOUT ON ALL 4 SIDES. SEE KO DIMENSION FOR MAXIMUM PIPE O.D.
5	1	PRECAST CATCH BASIN MFG: PARKUSA 888-611-PARK WWW.PARKUSA.COM MODEL: CB4880

NOTE: RISER SECTION AVAILABLE IN 6" TO 12" DEPTHS.

MODEL	W1	W2	H1	H2	T1	T2	KO	GRATE SIZE	OPEN AREA	WEIGHT LBS
CB-30	42"	30"	42"	36"	6"	30"	30"x30"x2"	490	3,675	
CB-36	48"	36"	42"	36"	6"	32"	30"x30"x2"	693	4,585	
CB-48	60"	48"	54"	48"	6"	48"	30"x30"x2"	693	7,250	
CB-60	72"	60"	66"	60"	6"	60"	30"x30"x2"	693	10,500	
CB-72	84"	72"	78"	72"	6"	72"	30"x30"x2"	693	15,300	
CB-84	96"	84"	78"	72"	6"	72"	30"x30"x2"	693	19,500	

SPECIFICATIONS

CONCRETE: CLASS I/II CONCRETE WITH DESIGN STRENGTH OF 4500 PSI AT 28 DAYS. UNIT IS OF MONOLITHIC CONSTRUCTION AT FLOOR AND FIRST STAGE OF WALL WITH SECTIONAL RISER TO REQUIRED DEPTH. RATED FOR H-20 LOADING.

REINFORCEMENT: GRADE 60 REINFORCED WITH STEEL REBAR TO CONFORM TO ASTM A631 ON REQUIRED CENTERS OR EQUAL.

CL. CASTINGS: CAST IRON FRAMES AND GRATES ARE MANUFACTURED OF GREY CAST IRON CONFORMING TO ASTM A48-76 CLASS 30.

PROJECT: _____
CUSTOMER: _____
ENGINEER: _____
ORDER #: _____ **PROJ #:** _____
DATE: _____ **LOCATION:** _____

PARK USA
www.parkusa.com 888-611-PARK
TYPE-A GRATE INLET MODEL: CB4880 30" THRU 84"

PM PC DRN ENG DWG. NO. REV.
DATE 12/2020 CB4880-1

LANGAN
 Langan Engineering and Environmental Services, Inc.
 9606 N. Mopac Expressway, Suite 110
 Austin, TX 78759
 T: 737.289.7800 F: 737.289.7801 www.langan.com
 TBPE FIRM REG. #F-13709

COPYRIGHT © HEDK Architects ALL RIGHTS RESERVED